

ATC “NITTA CHANGE SYSTEM”

“XC60”

USERS GUIDE  
MAINTENANCE & INSTRUCTION  
MANUAL

**Nitta Corporation**

BUSINESS DEVELOPMENT CENTER MECHATRONICS SYSTEMS DEPT.

---

# CONTENTS

PRECAUTIONARY NOTES	3
1.EQUIPMENT DESCRIPTION	4
1-1 Robot side	4
1-1-1 Robot Adaptor	4
1-1-2 Robot Adaptor Plate (OPTION)	5
1-2 Tool Side	5
1-2-1 Tooling Adaptor	5
1-2-2 Tooling Adaptor Plate (OPTION)	5
1-3 Option	5
2. COMPONENTS	6
3. STANDARD SPECIFICATION	7
3-1 XC60 Main Body specification	7
3-2 Chucking sensor specification	8
3-2-1 Ace contact sensor	8
3-2-2 Chuck /Unchuck lead switch	9
3-3 Load Allowance and Installation Notes	10
3-4 Power Load Allowance	10
4. IDENTIFYING THE XC60	11
5. INSTALLATION	12
5-1 Robot Adaptor	12
5-2 Tooling Adaptor	12
5-3 Chuck/Unchuck Port Connections	13
5-4 Wiring	13
5-5 User Air Connections	13
5-6 Cable Settlement	13
5-7 Tool Changer Installing Considerations	14
5-7-1 Tool Changer Application	14
5-7-2 Tool Changer Surroundings	14
5-7-3 I-mark	14
6. OPERATION AND PROGRAMMING	15
6-1 Operation and Programming	15
6-2 Basic Flow of The NITTA CHANGE SYSTEM	15
6-3 NITTA CHANGE SYSTEM Interlocks	16
6-4 Operation Considerations	16
6-5 Emergency	18
6-5-1 Manual Separation of XC60	18
6-5-2 Collision or Interference Managements	19
6-5-3 Water splashing treatment	19
6-6 Attention in the usage of servo motor in the tool side	19

7. INSPECTION AND MAINTENANCE .....	20
7-1 Inspection and Maintenance Schedule .....	20
7-2 Inspection Spots .....	21
7-3 Maintenance outlines .....	22
7-3-1 Lubrication on the XC60 Body.....	22
7-3-2 Replacing electrical contacts of the Tooling Adaptor.....	22
7-3-3 Replacing O-Rings of the Air Port.....	23
7-3-4 Checking Chucking Sensor.....	24
7-3-5 Replacing Tapered Pin.....	24
7-3-6 Replacing Locating Bushings .....	25
7-3-7 Replacing Tooling Adaptor Lock-pins .....	25
8. SPARE PARTS .....	26
9. BACK UP SYSTEM.....	26
10. TROUBLE SHOOTING .....	27
10-1 Trouble Factors (Cause Chart) .....	27
10-2 Trouble phenomena and shooting.....	27
10-2-1 The NITTA CHANGE SYSTEM does not work.....	27
10-2-2 The NITTA CHANGE SYSTEM can not exchange signals .....	29
10-2-3 The NITTA CHANGE SYSTEM has air leakage.....	30
10-2-4 The NITTA CHANGE SYSTEM gets heat .....	30
10-2-5 Tool (Gun, Hand, etc.) does not work.....	30

## REFERENCE DRAWINGS

# PRECAUTIONARY NOTES

The use of this document is reserved exclusively for the use of Nitta Corporation (hereinafter “the Corporation” ) customers and personnel. The information and drawings contained herein are the sole property of the Corporation, and shall not be divulged to any third party without the prior written consent of the Corporation. The Corporation makes no warranty of any kind with regard to this user's guide, including, but not limited to, implied warranties or fitness for a particular purpose. The Corporation shall not be liable for any errors contained herein or for incidental or consequential damages in connection with the performance or use of this user's guide.

This manual contains all the information about XC60 for proper operation and maintenance.

Please, make sure that all the personnel read and understand this manual thoroughly before using the NITTA CHANGE SYSTEM XC60 system, and certainly hand this manual to the person who operates this system.

Please, check the inside of packages, and make sure about next 2 items are inside of the shipment.

1. Installing bolts
2. Preliminary parts (depending on special arrangement)

We carefully pack our shipments. But, unfortunately you find any missing parts, please contact with our offices on the cover of this manual.

Thank you for choosing our NITTA CHANGE SYSTEM.

## 1.EQUIPMENT DESCRIPTION

The NITTA CHANGE SYSTEM is the pneumatic auto-tool exchanger. It is made up of two parts : a Robot Adaptor and a Tooling Adaptor. The system can be attached to any tooling by a optional adaptor plate, and also equips chucking mechanisms such as connecting pins and air ports.

### 1-1 Robot side

#### 1-1-1 Robot Adaptor

The Robot Adaptor is the basic part of the NITTA CHANGE SYSTEM.

This adaptor equips the sensor, which indicates the state of chucking mechanisms. This sensor outputs “CHUCK”, “UNCHUCK” and “FACE” signals.

#### [Chucking Mechanism]

The Robot Adaptor and the Tool Adaptor are connected each other by cams. These cams have special mechanism, which automatically adjusts for any dimensional error that may occur during chucking.

These cams are driven by air cylinders, and designed so that they will not release even if the units is subjected to more than its rated load capacity. If an extreme load is applied, the chucking surfaces of both the robot and tooling adaptors separate slightly but never release.

And the springs extend air cylinders provide fail-safe mechanism which avoids falling the tooling adaptor off even if the units loses its air pressure accidentally.

#### [Chucking Sensing Signals]

- Chuck complete signal(CHUCK)

This signal indicates that the cams of both adaptors are completely chucked.

That is, it indicates that the robot can move the Tooling Adaptor from the tool storage fixture.

- Cam released signal(UNCHUCK)

This signal indicates that the locking cam is retracted in the Robot Adaptor.

That is, it indicates that the cams are at the proper position to allow the Robot Adaptor to approach or unchuck the Tooling Adaptor.

- Face contact(FACE)

This signal indicates that the faces of both adaptors are in contact each other.

That is, it indicates that the chucking surfaces of both adaptors are properly contacted, so that the cams can be brought into engagement.

#### [Chucking mechanism]

Six air connection ports and fifteen electrical signal contacts are provided in the NITTA CHANGE SYSTEM XC60.

### 1-1-2 Robot Adaptor Plate (OPTION)

The Robot Adaptor plate allows the mating of the Robot Adaptor unit to your robot.

Nitta Corporation can provide the Robot Adaptor plate, or you can provide your own Robot Adaptor plate.

Refer to the Reference Drawings at the back of this manual for details on the bolt drilling locations.

### 1-2 Tool Side

#### 1-2-1 Tooling Adaptor

The Tooling Adaptor is another basic part of the NITTA CHANGE SYSTEM and allows your tools to be attached.

The locking cams of the Robot Adaptor will be engaged to the lock pins of this adaptor.

#### 1-2-2 Tooling Adaptor Plate (OPTION)

The Tooling Adaptor plate allows the mating of the Tooling Adaptor unit and your tools.

Like the Robot Adaptor plate, Nitta Corporation can provide the Tooling Adaptor plate, or you can provide your own Tooling Adaptor plate.

Refer to the Reference Drawing at the back of this manual for details on the bolt drilling locations.

### 1-3 Option

Please ask us about the details of non-standard options such as signal-pin module, electric module and pneumatic module.

## 2. COMPONENTS

This system is composed of the XC60 Body and the signal-pin Assembly.

This assembly consists of fifteen electrical signal contacts with spring contact pin.

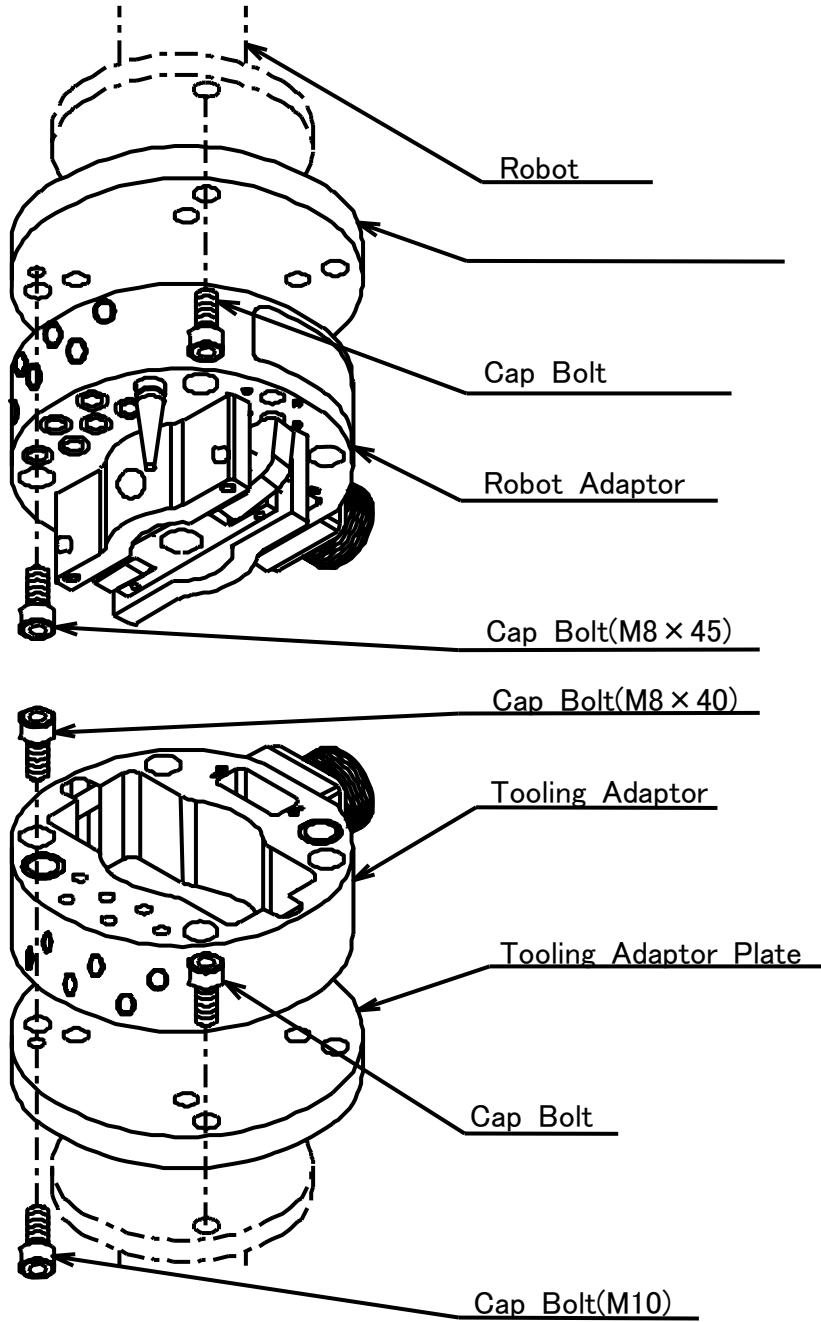

Fig. 1 System

### 3. STANDARD SPECIFICATION

3-1 XC60 Main Body specification.

Spec.		XC60	
1.	Main System		
1. Type	Robot Adaptor		refer to the drawing
	Tooling Adaptor		refer to the drawing
2. Rating	Handling capacity		60 kg
	Allowable moment		441Nm (4500 kgf·cm)
	Allowable torque		441Nm (4500 kgf·cm)
	Operation pressure		0.39~0.59MPa (4~6 kg/cm <sup>2</sup> )
3. Position Repeating Accuracy			0.025 mm
4. Interface	Electric	No. of contacts	refer to the drawing
		Electric capacity	3 A
	Pneumatic	No. of ports	6
		Normal pressure	0.855MPa (8.75 kg/cm <sup>2</sup> )
		Effective sectional area (C.v. value)	11mm <sup>2</sup> (0.63)/port (Rc1/8 port)
5. System weight	Robot Adaptor		1.0 kg
	Tooling Adaptor		0.5 kg
6. Dimension	Robot Adaptor		refer to the drawing
	Tooling Adaptor		refer to the drawing
Option (Special Order)			

3-2 Chucking sensor specification

3-2-1 Ace contact sensor

	DC 2-Wire Regular Cylindrical Proximity Sensors
Catalog listing	FL7M-2J6HD-903
Wiring method	prelead ed M 8
Rated sensing distance	2 ± 0 . 2 m m
Usable sensing distance	0 to 1.4mm
Standard target object	8 x 8 x 1mm iron
Differential travel	15% max. of sensing distance
Operating frequency	2 kH z
Indicator lamps	N.O. type: Operation indication: lights up (orange or green) upon output Setting indication: lights up (green) in stable sensing area N.C. type: Operation indication: orange light goes out in sensing area
Switching current	3 to 100mA
Circuit protection	Surge absorption, load short-circuit protection, reverse connection protection circuit
Rated supply voltage	12/24Vdc
Leakage current	0.55mA max.
Protective structure	IP67 (IEC standard), IP67G (JEM standard)
Operating temperature	-25 to +70°C
Insulation resistance	50MWmin. (by 500Vdc megger)
Dielectric strength	1,000Vac, 50/60Hz for 1 minute
Vibration resistance	10 to 55Hz, 1.5mm peak-to-peak amplitude, 2 hrs each in X, Y and Z directions
Shock resistance	980m/s <sup>2</sup> 10 times each in X, Y and Z directions

3-2-2 Chuck /Unchuck lead switch

Appellation		SMC no-contact auto-switch
Type		D-F7BV
Class		DC double line
Detecting object		magnetic metal
Differential distance		less than 1mm
Operation state		N.O (normal open)
Rating	Source voltage	DC24V (DC10~28V)
	Leakage current	less than 1mA (DC24V)
	Inner falling voltage	less than 3.0V
Atmosphere resistance	Protecting Structure	IP-67 (IEC standard)
	Temperature	-10~+60°C (without freezing)
	Insulation resistance	more than 50MΩ (at 500MV)
	Shock	apprx.102G

3-3 Load Allowance and Installation Notes

The specified rating load, moment and torque of NITTA CHANGE SYSTEM XC60 expresses the active state after the system is installed on a robot.

The system should be setted with consideration of inertia and acceleration generated by movements of the

robot, so that the maximum load of normal operation will never be over those ratings.

The rating load, moment and torque are explained on figure 2.

carrying load  $W = 60\text{kg}$

eccentricity  $L = \sqrt{l_m^2 + l_t^2}$

allowable bending moment  $M = L \times W \times G_R$  (note)

$$= \frac{50}{100} \times 60 \times 9.8 \times 1.5 \leq 441 \text{ N}\cdot\text{m} \{4500\text{kgf}\cdot\text{cm}\}$$

allowable twisting torque  $T = l_t \times W \times G_R$  (note)

$$= \frac{50}{100} \times 60 \times 9.8 \times 1.5 \leq 441 \text{ N}\cdot\text{m} \{4500\text{kgf}\cdot\text{cm}\}$$

(note)  $G_R$  represents the acceleration of the Robot at normal motion in automatic operations.  $G_R$  value of a robot will be different on each other. Please refer to the manufacture of your robots about the precise  $G_R$  value. (Generally,  $G_R$  is sited between 1.5 to 2.0G)

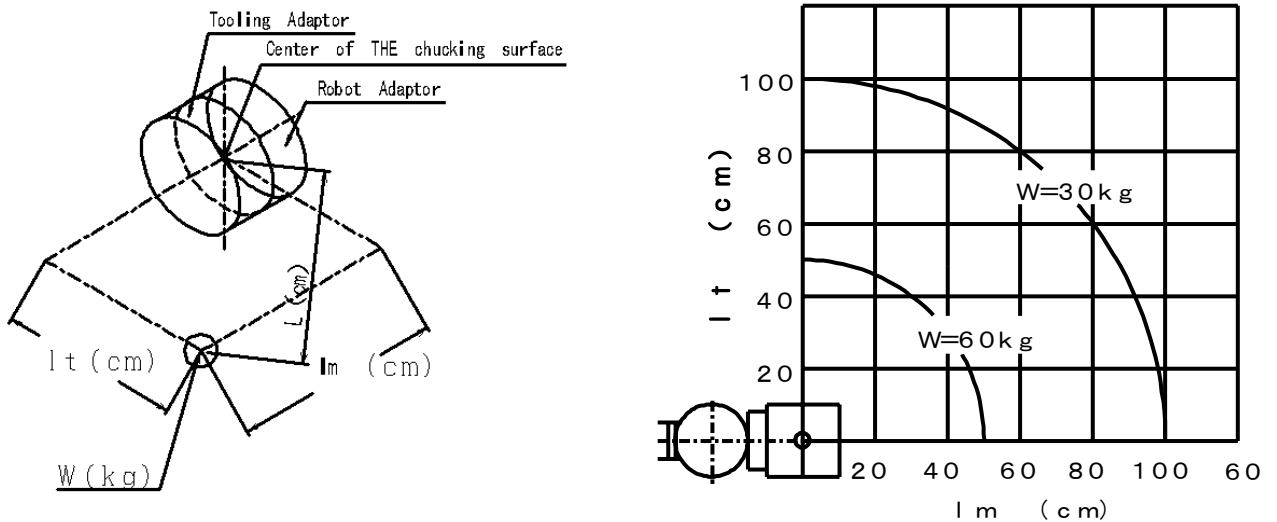

Fig. 2 Definition of load rating

3-4 Power Load Allowance

The NITTA CHANGE SYSTEM XC60 can carry 15A of the maximum current in all, when it has the standard signal-pin assembly (15 connecting pins). And it can carry 3A, 110V per pin. However, the current over 3A should not be applied on adjacent pins at the same time when the plural numbers of user signal pins are used.

#### 4. IDENTIFYING THE XC60

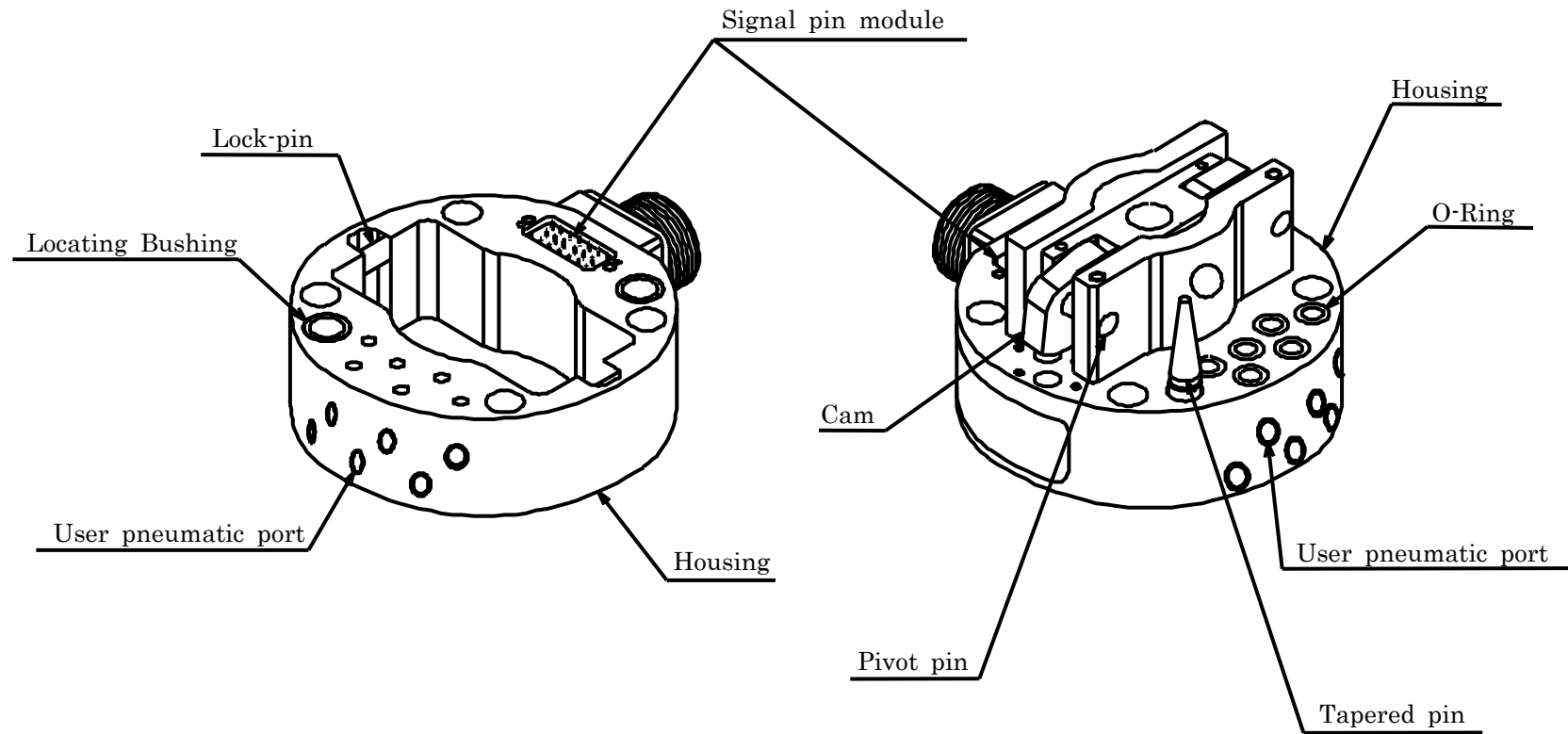

Fig. 3 Identification





5-7 Tool Changer Installing Considerations

5-7-1 Tool Changer Application

It is suggested that the center of load is on a line which has the same direction of the cam on the tool changer to minimize a gap between the chucking surfaces.

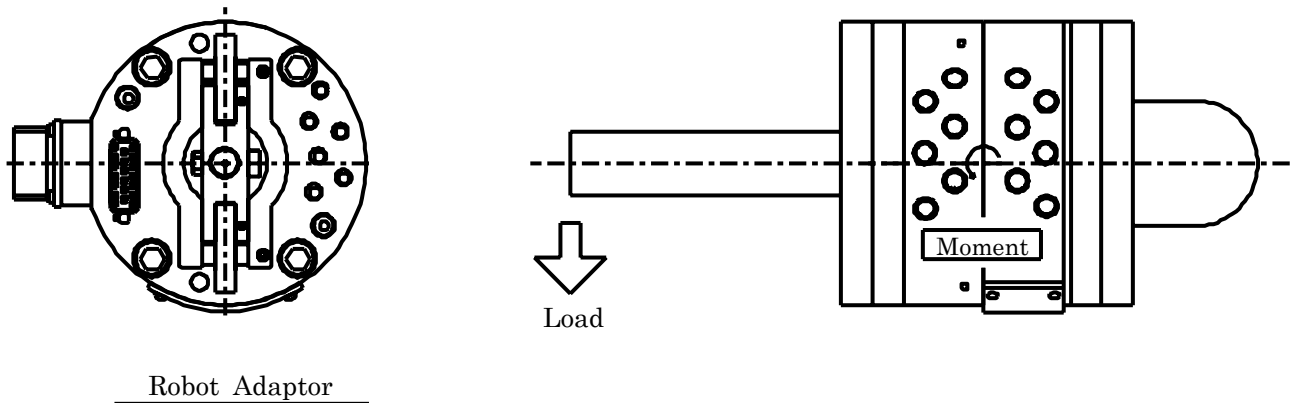

Fig. 5 Tool Changer Installing Direction

5-7-2 Tool Changer Surroundings

The Tool Changer can be manually detached in urgent. The Tool changer can not be detached if any object obstructs an insertion of the jig into the hole, which is provided, on the Tooling Adaptor for detaching.

Beware of that there is no object such as a terminal box on the material handling apparatus around the hole.

5-7-3 I-mark

I-marks on the adaptor plates and the adaptors are suggested to check any shifting due to excessive load, or to speed up the maintenance.

And also I-marks on the Tooling Adaptor and the Robot Adaptor ease up the teaching process.

## 6. OPERATION AND PROGRAMMING

### 6-1 Operation and Programming

This chapter shows the example of the interlock signals surrounding the XC60.

Exchanging signals, which synchronize the robot with surrounding systems or confirm movements of the robot are necessary to maintain reliance and safety on the XC60.

The XC60 has three sensors for detecting movements of itself. Refer to “1.EQUIPMENT DESCRIPTION” for details.

### 6-2 Basic Flow of The NITTA CHANGE SYSTEM

Please adjust the interlocks of your robot with referring to this flow chart

Indicates processing condition.

Robot motion		Input			Robot Output		External Input
		XC60 Chucking Sensor			controlling solenoid valve		Fixture Limit switch
		Face	Chuck	Unchuck	Chuck	Unchuck	Tool side
C H U C K I N G  U N C H U C K I N G	Waiting position	OFF	OFF	ON	OFF	ON	ON
	↓						
	Moving	↓	↓	↓	↓	↓	↓
	↓						
	Near by chucking position	<input type="checkbox"/>	<input type="checkbox"/>	<input type="checkbox"/>	↓	↓	<input type="checkbox"/>
	↓						
	Approaching	<input type="checkbox"/>	<input type="checkbox"/>	<input type="checkbox"/>	↓	↓	<input type="checkbox"/>
	↓						
	Chucking position	<input type="checkbox"/> ON	<input type="checkbox"/>	<input type="checkbox"/>	↓	↓	<input type="checkbox"/>
	↓						
	Chuck	<input type="checkbox"/>	<input type="checkbox"/> ON	<input type="checkbox"/> OFF	ON	OFF	<input type="checkbox"/>
	↓						
	Chucking completion	<input type="checkbox"/>	<input type="checkbox"/>	<input type="checkbox"/>	↓	↓	<input type="checkbox"/>
↓							
Moving	<input type="checkbox"/>	<input type="checkbox"/>	<input type="checkbox"/>	↓	↓	OFF	
↓							
Working	<input type="checkbox"/>	<input type="checkbox"/>	<input type="checkbox"/>	↓	↓	↓	
<hr style="border-top: 1px dashed black;"/>							
Working	<input type="checkbox"/> ON	<input type="checkbox"/> ON	<input type="checkbox"/> OFF	ON	OFF	OFF	
↓							
Moving	<input type="checkbox"/>	<input type="checkbox"/>	<input type="checkbox"/>	↓	↓	<input type="checkbox"/>	
↓							
Unchuck position	<input type="checkbox"/>	<input type="checkbox"/>	<input type="checkbox"/>	↓	↓	<input type="checkbox"/> ON	
↓							
Unchuck	<input type="checkbox"/>	<input type="checkbox"/> OFF	<input type="checkbox"/> ON	OFF	ON	<input type="checkbox"/>	
↓							
Leaving	<input type="checkbox"/> OFF	<input type="checkbox"/>	<input type="checkbox"/>	↓	↓	<input type="checkbox"/>	
↓							
Near by unchucking position	<input type="checkbox"/>	<input type="checkbox"/>	<input type="checkbox"/>	↓	↓	<input type="checkbox"/>	
↓							
Moving	↓	↓	↓	↓	↓	↓	
↓							
Waiting	↓	↓	↓	↓	↓	↓	

During Robot is working, condition the signal as “Face ON.”

### 6-3 NITTA CHANGE SYSTEM Interlocks

Setting next four signals are suggested for safe and smooth operation of the Tool Changer.

#### 1) Low Pneumatic Detection Signal

This is a signal, which warns lost of the Tool Changer pneumatics. It stops a manner of the robot when the signal is off.

#### 2) Tool existence detection signal

This is a signal, which detects existence of the tools on the Tool Storage Fixture.

This Interlock signal allows the Unchuck valve open only when all the tools are on the Fixture.

So, it prevents falling off of the tools for the event of unexpected situation.

#### 3) Tool Number Identification Signal

This is a signal, which checks the matching between the equipped tool and its programmed number.

So, the signal is useful when several robots chuck with the Material Handling apparatus from the same Tool Storage Fixture.

#### 4) Tool changer Manner Indication Lamp

Setting lamps, which indicate the ON/OFF state of signal such as the Chuck, Unchuck, Face, or User signal, are suggested for understanding condition of the system for trouble detection.

### 6-4 Operation Considerations

The Tool Changer requires that the chucking surfaces of both the Robot and the Tooling Adaptors are in parallel during chucking action. If the interface parallelism is not obtained, chucking or separation difficulties may occur.

A compliant Tool Support Fixture is recommended when the parallelism of the Robot or the Fixture can not be obtained.

When the fixture has compliance, teaching the chucking can be done by that the robot presses the Robot Adaptor against the Tooling Adaptor as if both faces of the Adaptors cohere each other (design a compliance with considerations about such thing as thrust of the robot, weight of the tool, flatness, and discrepancy of the center).

A partial load of the tool or reaction forces on electric connections and ports for pneumatic or cooling water cause to leaning of the Tooling Adaptor followed by twisting of a part of the chucking mechanism at their separation, so that the Adaptors will not separate completely.

In this case, it is necessary for the robot to press the Robot Adaptor against the Tooling Adaptor, as same as the application of chucking, in order to keep a fixed position of the Tooling Adaptor just after the separation.

(Preventing lean, shift, etc.) At this time of the separation movement, the tool should be certainly on the Fixture.

Teach the separation movement to the robot with a series of manner that confirming the disengagement of the mechanism followed by smooth retreating of the Robot Adaptor without being trapped.

For avoid these troubles mentioned in the prior page, it is recommended that the Fixture of the Tool Changer is sited in horizontal.

But, if a vertical setting is the only plan to be allowed because of available space, be sure with next considerations.

- 1) No jolting of the Tool Storage Fixture (without compliance).
- 2) No shifting of the Tool (Material Handling Apparatus, etc.) during chucking/separation movements of the Tooling Adaptor. (A structure supported at a point as close as possible to the Tooling Adaptor)
- 3) Satisfying the rigidity of the fixture not to be bent and the anchor bolts of the Fixture should not be pulled out or loosen by pressure application of the Tooling Adaptor during chucking.
- 4) Wear resistance of the Fixture support parts at the Tooling Side.  
Using exchangeable parts are suggested.

WHEN THE TOOLING ADAPTOR IS NOT AT THE FIXED POSITION FOR THE TOOLING STORAGE FIXTURE, DO NOT INADVERTENTLY OPERATE THE CAMS. RELEASING THE TOOLING ADAPTOR WHEN THE TOOLING ADAPTOR IS NOT AT THE FIXED POSITION FOR THE TOOLING STORAGE FIXTURE MAY NOT ONLY DAMAGE THE TOOLING ADAPTOR UNIT AND PERIPHERAL EQUIPMENT BUT ALSO CAUSE HARM TO THE OPERATOR.

When using the NITTA CHANGE SYSTEM for burring or other material removal operations, be sure to position the Tooling Adaptor Support Fixture so that the Tooling Adaptors are protected from contamination by removed material, coolants, and so forth.

Use a self-open/close cover (NITTA CHANGE SYSTEM Cover) for the Tool Adaptor protection. If the Fixture is exposed to bad environment such as spatter, drops and dust.

For oily environment, keep good contact on signal pins by cleaning with blowing, etc.

Nitta Corporation is providing standardized surrounding equipments of the NITTA CHANGE SYSTEM.

Please ask for such equipments the Fixture, the NITTA CHANGE SYSTEM Cover, and the Falling off Prevention system, etc. when you need.

6-5 Emergency

6-5-1 Manual Separation of XC60

XC60 has holes on the Tooling Adaptor.

So that the cams will be manually turned off for separation.

- ① Be sure that the falling prevention is prepared strong enough so that the Tooling will not fall.  
(Example, suspending Tools by Rope)
- ② Confirm the air application on "UNCHUCK" port
- ③ Turn back the cams carefully (without any scratching on the cam's surface) with a screwdriver, etc.  
When a cam is turned back, the gap between chucking surfaces of the XC60 is produced and distortion may occur. So, minimize the gap not to produce distortion during the separation.

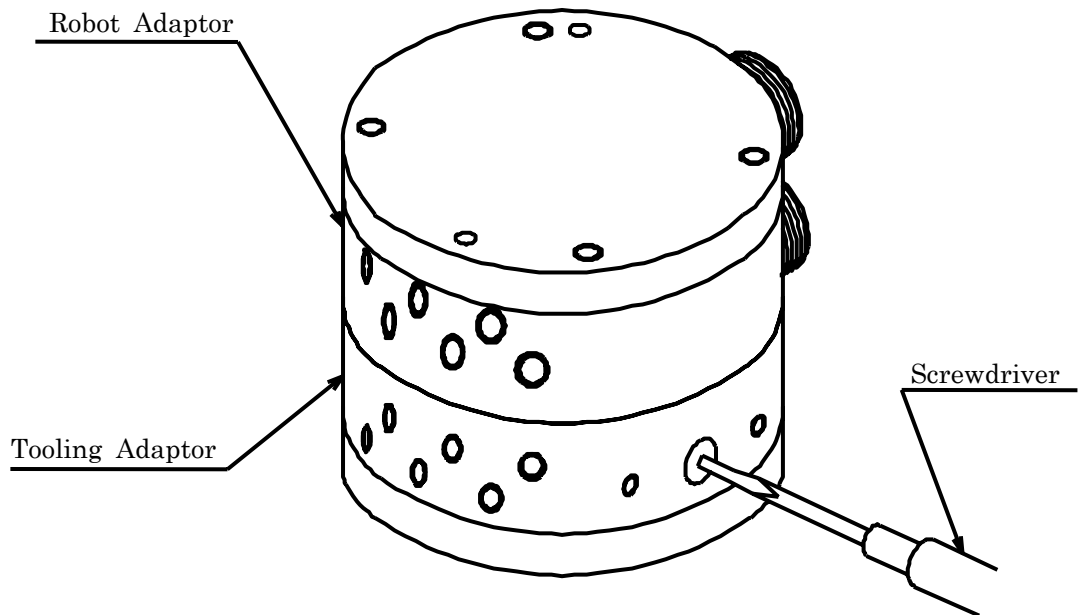

Fig. 6 Manual separation

### 6-5-2 Collision or Interference Managements

When a robot or the jigs (gun, transformer, etc.) on the robot collides or interfere with the Work, do the checks and the treatments as the following chart. A collision applies excessive force which cause to deterioration of the durable years on the NITTA CHANGE SYSTEM.

Therefore, making an earlier periodic inspection is suggested even though the any disorder is not found on the system. Refer the chapter "7.Maintenance and Inspection" about replacing the body and damaged parts.

#### Interference, collision treatment

	Inspection points	Method	Disorder management
1	crack	visually check	body replacement
2	housing distortion	visually check	body replacement
3	bolt looseness	check the part	tighten up
4	cam chuck/unchuck movement and signals	manually turn ON/OFF the valve with checking the signal and the movement	body replacement
5	gap between chucking surfaces	Visually check the damages on cam surface, lock pin, pivot pin, and interface.	replacing damaged parts
6	jolt for rotating	visually check the damage of taper pin, bushing, the looseness of bolt	replacing damaged parts
7	damage on electric signal pin, connector and cable	visually check check signals on I/O plate	body replacement or replacing damaged parts

### 6-5-3 Water splashing treatment

Avoid splashing with water for long period. The system does not matter with little spattering. But, if the system is covered with water, do the checks and treatments showing below.

#### Water splashing treatment

	Inspection points	Method	Treatment
1	electric points and proximity switch signals	Check any short on I/O unit side. Visually check standing water	wipe off with cloth
2	cam, lock-pin tapered pin	visually check	apply grease
3	O-Ring fitting part	visually check	apply grease
4	other points covered with water	visually check with standing water	wipe and apply oil on naked part of metal

### 6-6 Attention in the usage of servo motor in the tool side

If you use tools with servo motor like servo gun and servo matehan,

Install the memory battery in tool side because encoder memory will be erased at the uncouple time.

## 7. INSPECTION AND MAINTENANCE

### 7-1 Inspection and Maintenance Schedule

Basic inspections are scheduled as seven stages such as daily, monthly, every 3 months, every 6 months, yearly, every 2 years and overhaul. Inspection points are added as the stage of inspection is proceeding. Refer the chart on next page about the Inspection points on each stage.

A proper maintenance in time, not only saves wearing of mechanisms but also prevents disorders and secures safety. Observe periodic Inspections according to the schedule.

This Inspection schedule is based on the one shift system as a standard time so that the schedule should be adjusted depending on the frequency of the robot use.

For example, A monthly inspection should be done by every two weeks (every 10000 use) if the robot is used in the two shift system.

Standard cycle time :

$$1^{use}/_{min} \times 60^{min}/_{hr} \times 8^{hrs}/_{day} \times 22^{day}/_{month}$$

$$=10560^{use}/_{month}$$

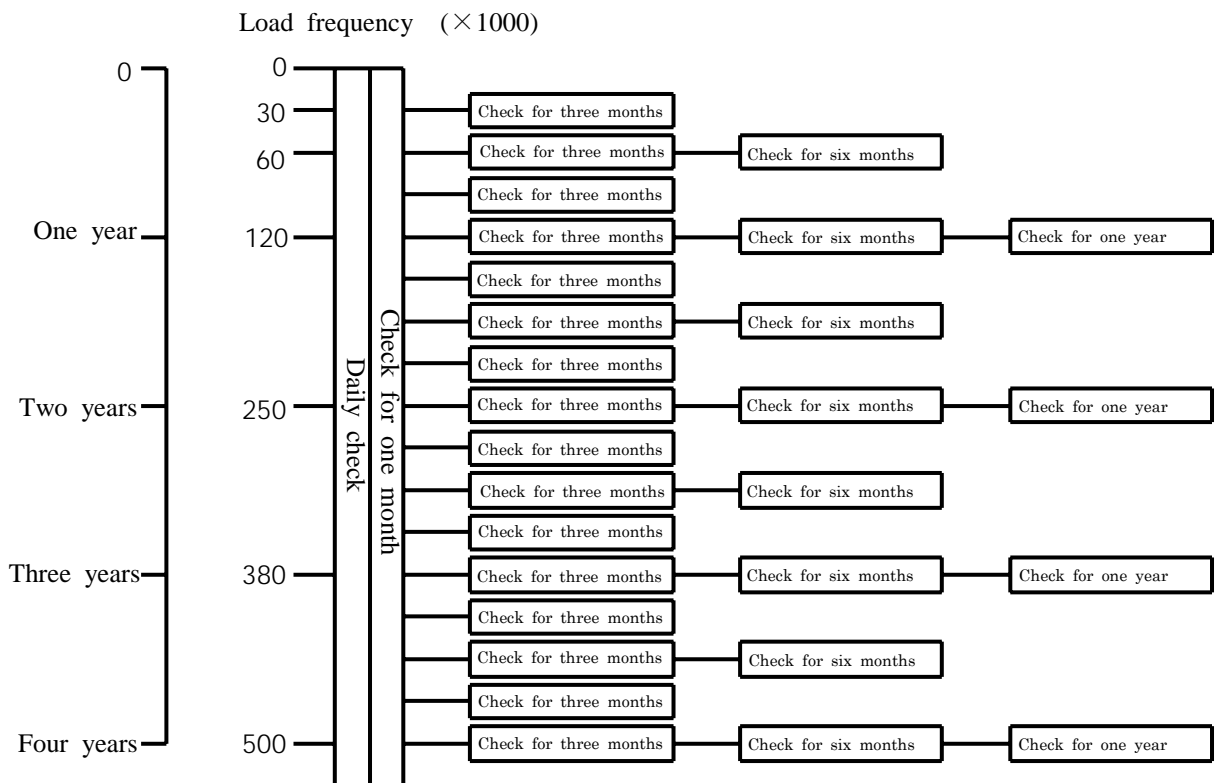

7-2 Inspection Spots

Inspections are distinguished with seven stages as shown on the chart 1, which indicates points of inspection.

Refer to the inspection points, which are mentioned later about maintenance method.

Chart 1, Inspection Points

Period	Inspection points	Method
Daily	Checking signal-pins	Visually
	Checking air leakage	Visually
	Checking parallelism of interface (no gap)	Visually
	Checking foreign matters on the chucking surfaces	Visually
	Lubricating chucking parts and sliding parts	refer 7-3-1
1 month	Lubricating all O-Rings	refer 5
	Checking tightness of the installation bolts	
	Checking tightness of the electric connector connections	tighten up
	Checking smoothness of the cams movements	visually
	Checking air leakage at the O-Ring of pneumatic ports	touching
3 months	Proximity switch fixation	Touching
	Pivot-pin, lock-pin and housing fixation	touching
6 months	Cam, Taper pin, Supporting pin, Bushing, and Interface fatigue	Visually
1 year	Cleaning spring pin contact	refer 7-3-2
	Replacing O-Rings at pneumatic ports	refer 7-3-3
4 years	Overhaul	

7-3 Maintenance outlines

Daily maintenance without removing the Adaptors from the system is mentioned in this chapter.

7-3-1 Lubrication on the XC60 Body

Apply a coating of SumiplexBN (Sumico Lubricant Co., Ltd.), or equivalent to the sliding surfaces shown in the figure below. (Do not apply molybdenum - based grease)

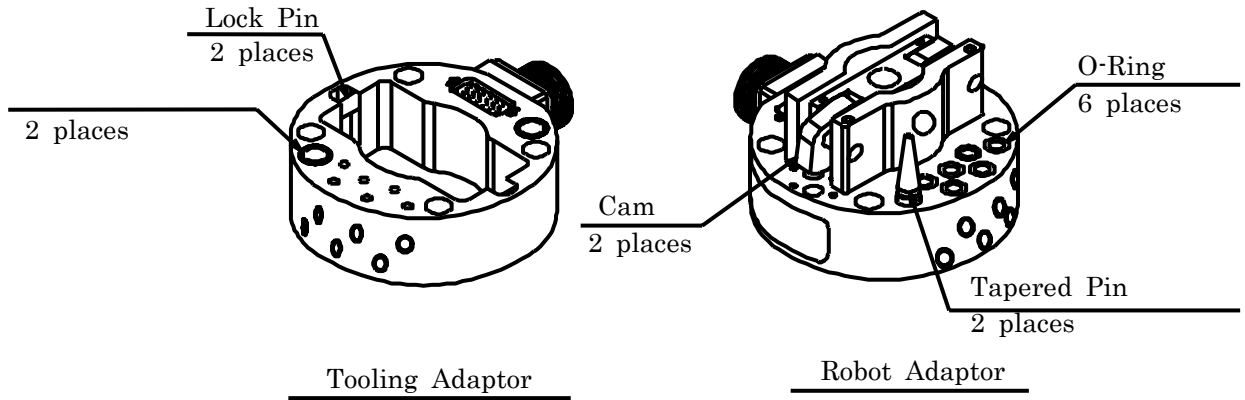

Fig.7 XC60 Lubricating spots

7-3-2 Replacing electrical contacts of the Tooling Adaptor

Grasp the tip of contact and pull directly upward, the pointed end and its brass receptacle will come off.

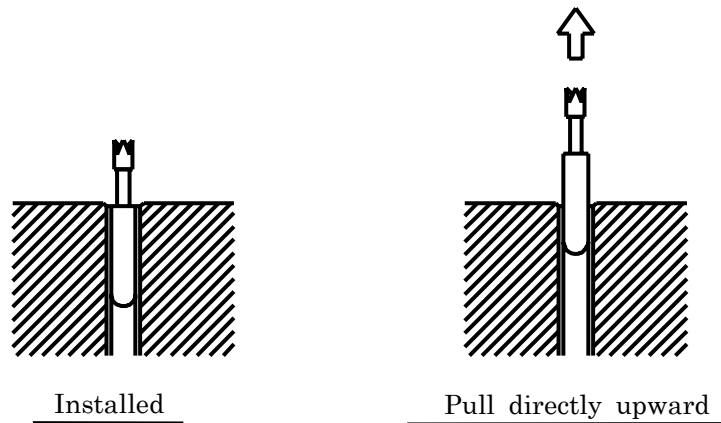

Fig.8 replacing the electrical contacts of the Tooling Adaptor

This work can be done with hands, but using a tool such as pliers makes it easy. After removing the damaged contact, a new pin is installed by fully pushing its receptacle into the body of the module.

Check height and movement of the pins.

If a pin is broken in the receptacle, use a pointed file( $\phi 2\sim 3\text{mm}$ , mid) to pull out the pin.

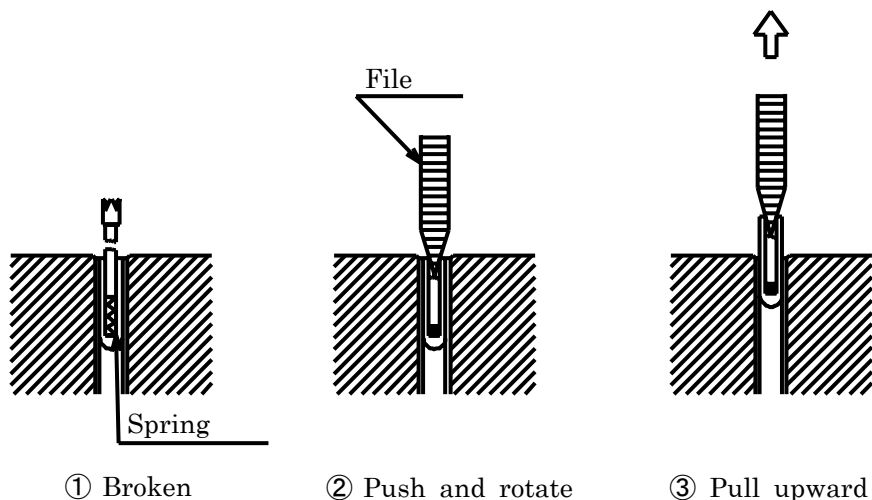

Fig. 9 removing a broken pin

### 7-3-3 Replacing O-Rings of the Air Port

The Robot Adaptor has O-Rings of the Air Port as shown on figure below.

Replace a O-Ring if any damage or air leakage occurs. The old O-Rings may be removed by marking-off pin. In this time, be careful not to scratch the Robot Housing. The new O-Ring should be replaced in air port after a coating of grease application (SumiplexBN or equivalent). Check any damage on pneumatic ports, tapered pin, wear of bushings, and/or wrong teaching. These disorders may cause frequent damages of O-Rings. (refer 6-4)

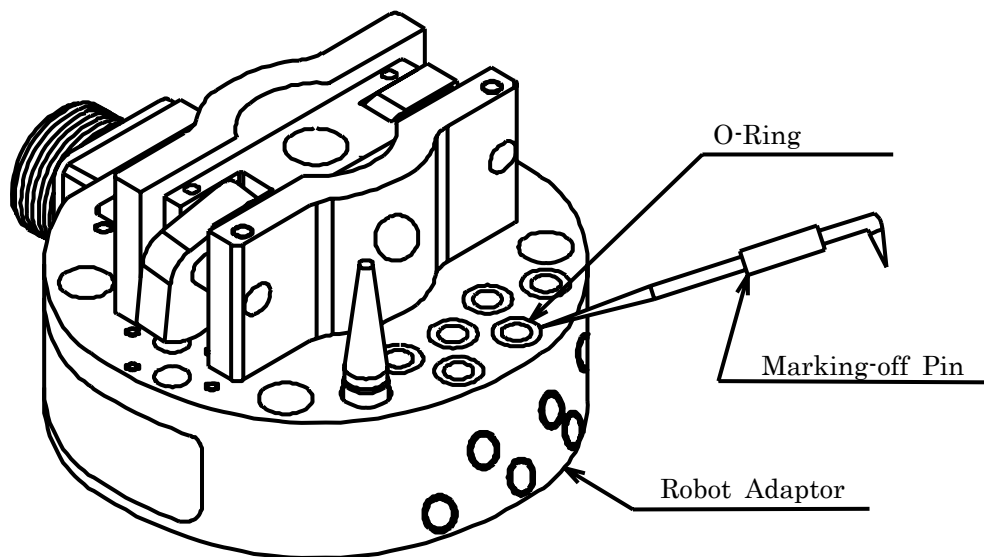

Fig. 10 Replacing O-Rings of the Air Port

### 7-3-4 Checking Chucking Sensor

Apply the power on the chucking sensor by sequencer, etc. and confirm that the LED is lit on. Refer with the electrical schematic about connections.

	CHUCK	UNCHUCK	FACE
ATC DISCONNECT (Unchuck)	OFF	ON	OFF
ATC CONNECT (Unchuck)	OFF	ON	ON
ATC CONNECT (Chuck)	ON	OFF	ON

### 7-3-5 Replacing Tapered Pin

Taper pins are screwed on the Robot Adaptor body. For removing a tapered pin, take off the installations bolt from inside of the Robot Adaptor first, then strike the pin out with punch, etc.

For assembling, apply a coating of Locktight 242 (medium strength) on the tapered pin before screwing its installation bolt, and also check that the tapered pin project out for 37mm.

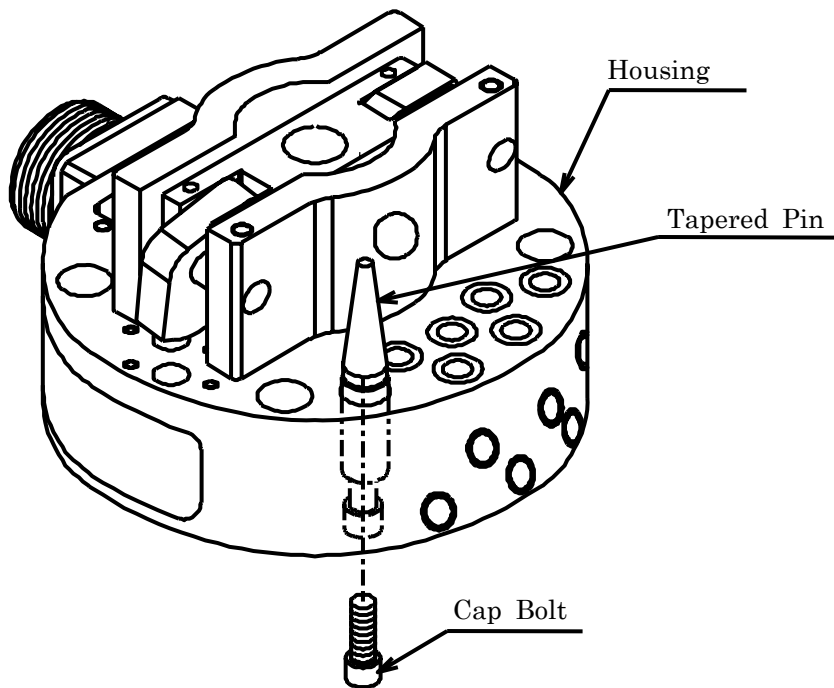

Fig. 11 Replacing Tapered Pins

### 7-3-6 Replacing Locating Bushings

Locating Bushings are pressed in the Tooling Adaptor body. For replacing, strike the Bushing out from A side.

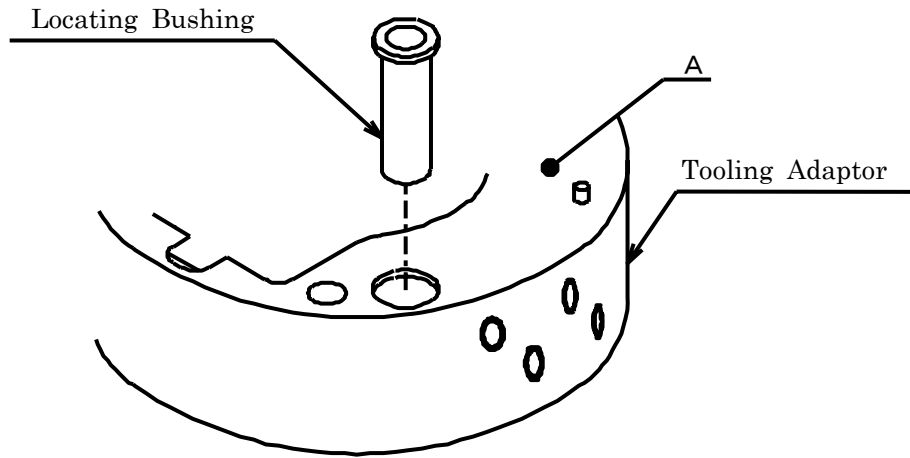

Fig. 12 Replacing Bushing

### 7-3-7 Replacing Tooling Adaptor Lock-pins

Lock-pins are assembled as slide fit. For Replacing, untaught the setting screw and strike the pin out with the special jig. Apply small amount of Locktight 222 (Low strength) on the setting screw after inserting the pin. Then, tight the setting screw with adjusting the position of hole B.

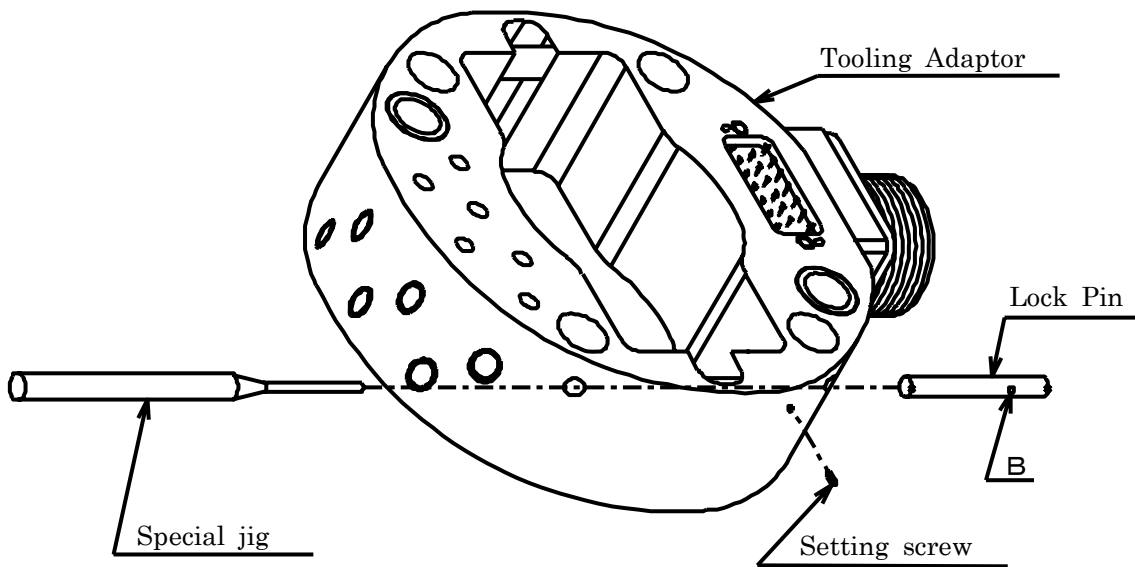

Fig. 13 Replacing Lock-pins

## 8. SPARE PARTS

Preparing spare parts of the XC60 with referring the parts ranks as defined in below is recommended. When purchasing spare parts, please ask us for the parts by their parts code. (serial number).

A rank : running stores, frequently replacing parts

B rank : parts of frequently moving mechanism

C rank : important parts

〈NITTA CHANGE SYSTEM XC60 body〉

Rank	Parts name	count	material	parts code
A	O-Ring (Robot)	6	NBR	P5
A	Electric Signal-Pin(Tool)	15	—	GCSPP2M333
C	Tapered Pin(Robot)	2	Steel	EBR-004-01
C	Pivot Pin(Robot)	2	Steel	EBR-00B-00
C	Locating Bushing(Tool)	2	Steel	EBT-002-01
C	Lock-pin(Tool)	2	Steel	EBT-003-00

For finding parts code, refer to the appropriate parts locating schematic at the back of this manual.

### Note for Replacing Work

Please contact with us, if you find any damage on the changer body (housing, etc.) during parts replacement.

Do not readjust or disassemble the proximity switch when replacing parts (shifting of the sensor may cause malfunction).

## 9. BACK UP SYSTEM

If a Tool Changer is required to rest for long period because of the occasion such as Inspection, Maintenance and Reparation, the Tool Changer can be replaced to the other Changer within  $\pm 0.5\text{mm}$  accuracy of reproducibility unless the applied Adaptor Plates are special order.

The system is composed of not only body but also various modules. As like the changer, the module can also be replaced by it only (excluding special module).

We suggest preparing the spare parts and the spare body for the backups, to minimize downtime of the line, when the line tact is fast or the parts consumption is much.

# 10. TROUBLE SHOOTING

## 10-1 Trouble Factors (Cause Chart)

- The NITTA CHANGE SYSTEM does not work.
  - Tools do not reposition for chucking.
  - Gap is produced at the chucking surfaces.
  - System is unable to chucked.
  - System is unable to unchucked.
- The NITTA CHANGE SYSTEM can not exchange signals.
  - Chuck sensor does not work.
  - Unchuck sensor does not work.
  - Face sensor does not work.
- The NITTA CHANGE SYSTEM has air leakage.
  - Air leakage at input pneumatic port.
- The NITTA CHANGE SYSTEM gets heat.
  - The Adaptor body gets heat.
- Tool (Guns, Hand, etc.) does not work.
  - Lost of pneumatics.
  - Unable to exchange CHANGE SYSTEM signals through electric signal-pins.

## 10-2 Trouble phenomena and shooting

### 10-2-1 The NITTA CHANGE SYSTEM does not work.

#### **Tools Do Not Reposition for Chucking**

- 1) Check any gap between the Adaptors. . . . . Readjust the teaching.
- 2) Check any damage or extreme wears of tapered pins. . . . . Replace the tapered pin.(Refer 7-3-5)
- 3) Check any damage or extreme wear of locating bushings. . . . . Replace the locating bushing(Refer 7-3-6)
- 4) Check looseness of installation bolts. . . . . Tighten up the bolt (Refer 5)
- 5) Check any overload on the body to change its shape. . . . . Contact with our office.
- 6) Check any load over the rating. . . . . Contact with our office.

### Gap is produced at the Chucking Surfaces

- |  |   |
|--|---|
| 1) Check the chucking with proper gap.                 | • • • • • Chuck at the position which the CHUCK sensor is ON.                           |
| 2) Check any foreign matter on the chucking surfaces.  | • • • • • Take it off   |
| 3) Check any overload on the body to change its shape. | • • • • • Contact with our office.  |
| 4) Check the application of molybdenum based grease.   | • • • • • Immediately change to SumiplexBN (Sumico Lubricant Co., Ltd.) or equivalents. |

### System is unable to be chucked

- |  |   |
|--|---|
| 1) Check pressure of the pneumatics.                       | • • • • • Apply pneumatic at pressure of 4~6kg/cm <sup>2</sup>        |
| 2) Check the function of solenoid valves.                  | • • • • • Confirm.  |
| 3) Check the distance of Adaptors.                         | • • • • • Press the Adaptors each other until proximity switch is ON. |
| 4) Check any object which interferes the function of cams. | • • • • • Remove it, take it out.                                     |
| 5) Check air leakage from the cylinder.                    | • • • • • Contact with our office.                                    |
| 6) Check any damage of the cylinder.                       | • • • • • Contact with our office.                                    |
| 7) Check any overload on the cam to change its shape.      | • • • • • Contact with our office.                                    |
| 8) Check deflection of the Fixture.                        | • • • • • Raise rigidity.   |
| 9) Check looseness of the Fixture anchor bolts.            | • • • • • Tighten up the bolt.  |

### System is unable to be unchucked

- |  |   |
|--|---|
| 1) Check pressure of the pneumatics.   | • • • • • Apply pneumatic at pressure of 4~6kg/cm <sup>2</sup>                    |
| 2) Check the function of solenoid valves.  | • • • • • Confirm.  |
| 3) Check any excessive partial load on the Tooling Adaptor.                      | • • • • • Press the Tooling Adaptor against the Fixture until CHUCK signal is ON. |
| 4) Check the function of interlock.  | • • • • • Confirm the circuit.  |
| 5) Check any object which interferes the cams.                                   | • • • • • Remove the object function of cams.                                     |
| 6) Check any overload which changes the shape of cams.                           | • • • • • Contact with our office.  |
| 7) Check the grease on the cams.   | • • • • • Apply grease to avoid the cams get be twisted.                          |
| 8) Check the proper force of pressure which is necessary to unchuck the Changer. | • • • • • Confirm.  |
| 9) Check deflection of the Fixture.  | • • • • • Gain the rigidity.  |
| 10) Check looseness of the Fixture anchor bolts.                                 | • • • • • Tighten the bolts.  |

10-2-2 The NITTA CHANGE SYSTEM can not exchange signals

**Chuck sensor does not work**

- 1) Check jolting of installation. . . . . Tighten up the installation plates.
- 2) Check leakage current of the Interlock plate. . . . . Adjust the leakage current to less than 1.3mA.
- 3) Check the cam position for chucking. . . . . Start the inspection from the hole for (chucking difficulties) manual separation. (Refer 6-5-1)
- 4) Check any gap between the Robot and Tooling Adaptors. . . . . Chuck at the position which the CHUCK sensor is ON.
- 5) Check the cable connection. . . . . Confirm.
- 6) Check any damage on cables. . . . . Confirm.
- 7) Check the function of Interlock plate. . . . . Check the circuit.
- 8) Check any damage or disorder of the sensors. . . . . Contact with our office.
- 9) Check any water splashing over the Changer (short of the electric lines). . . . . Contact with our office.

**Unchuck sensor does not work**

- 1) Check jolting of installation. . . . . Tighten up installation plates.
- 2) Check the leakage current of the Interlock plate. . . . . Adjust the leakage current to less than 1.3mA.
- 3) Check the cam position for chucking. . . . . Start the inspection from the hole for (chucking difficulties) manual separation (Refer 6-5-1)
- 4) Check the cable connection. . . . . Confirm.
- 5) Check any damage on cables. . . . . Confirm.
- 6) Check the function of Interlock plate. . . . . Check the circuit.
- 7) Check any damage or disorder of the sensors. . . . . Contact with our office.
- 8) Check any water splashing over the Changer (short of the electric lines). . . . . Contact with our office.

**Face sensor does not work**

- 1) Check jolting of installation. . . . . Tighten up installation plates.
- 2) Check leakage current of the Interlock plate. . . . . Adjust the leakage current to less than 1.3mA.
- 3) Check any metal substances on the sensors. . . . . Remove it.
- 4) Check any gap over 0.5mm between the Robot and Tooling Adaptors. . . . . Readjust the teaching.
- 5) Check the cable connection. . . . . Confirm.
- 6) Check any damage on cables. . . . . Confirm.
- 7) Check the function of Interlock plate. . . . . Check the circuit.
- 8) Check any damage or disorder of the sensors. . . . . Contact with our office.
- 9) Check any water splashing over the Changer (short on electric lines). . . . . Contact with our office.

10-2-3 The NITTA CHANGE SYSTEM has air leakage

**Air leakage at input pneumatic port**

- 1) Check any damage on O-Ring of the Air Port on the Robot Adaptor. . . . . Replace O-Ring. (Refer 7-3-3)
- 2) Check connection of the one touch joint of pneumatic. . . . . Confirm.
- 3) Check the applications of hoses. . . . . Confirm.
- 4) Check any gap between the chucking surface of the Robot and Tooling Adaptors. . . . . Chuck completely

10-2-4 The NITTA CHANGE SYSTEM gets heat

**The Adaptor body gets heat**

- 1) Check the high temperature in atmosphere. . . . . Keep away from heat
- 2) Check the electric power on signal spring-pin. . . . . Keep power application within the rating.

10-2-5 Tool (Gun, Hand, etc.) does not work

**Lost of pneumatics**

- 1) Check the pressure of pneumatic. . . . . Apply pneumatic at pressure less than 8.75kg/cm<sup>2</sup>
- 2) Check the function of solenoid valves Adaptors. . . . . Confirm.
- 3) Check the chucking of the Robot and Tooling Adaptors. . . . . Chuck completely (CHUCH sensor should be ON).
- 4) Check extreme bending or twisting on the hose. . . . . Confirm.
- 5) Check any damage on O-Rings of the Robot Adaptor. . . . . Replace O-Rings.
- 6) Check coincidence of port number between the Robot and Tooling Adaptor. . . . . Confirm.
- 7) Check any damage on the Tool. . . . . Confirm.

**Unable to exchange signals through electric signal-pins**

- 1) Check transmissions of signals to electric signal-pins. . . . . Check with tester, etc.
- 2) Check any damage on tools. . . . . Confirm.
- 3) Check extreme bending or twisting on the signal cables. . . . . Confirm.
- 4) Check the connection of connectors. . . . . Connect completely.
- 5) Check the chucking of the Robot and Tooling Adaptor. . . . . Chuck completely. (CHUCK sensor should be ON)
- 6) Check any damage on the electric signal-pin module. . . . . Contact with our office.
- 7) Check any foreign matter or damage on electric signal-pins of module. . . . . Replace electric signal-pin. (Refer 7-3-2)
- 8) Check any projection or dent of electric signal-pin(height of pins should be same). . . . . Contact with our office.
- 9) Check the movement of electric signal-pin (movement should be smooth). . . . . Replace electric signal-pins. (Refer 7-3-2)

