

Linemate[™]



Features of Nitta thermoplastic hoses

Clean and Eco-friendly

Smooth inner surface of the plastic hoses keeps the operating oil clean.

Assembly on Site

With the one-touch coupling "CAMPUCKA" or assembly tool "Mark 10" it is easy to adjust length on site.

High Durability

Nitta hose is highly durable against impact pressure and repeated bending, because of the synthetic fiber reinforcement.

High Abrasion Resistance

Nitta hose has high abrasion resistance because special polyurethane resin is used as the cover material.

Light weight

Nitta hose weighs about a quarter to half that of rubber hose.

Compact Bend Radius

Small outer diameter enables installation in applications requiring compact bend radius.

I N D E X

Features of Nitta thermoplastic hoses 1

Precautions for use 3

Hose products 5

How to Order Hose Assembly Items	5	
Hose selection table	5	
Types of hose couplings for various hose-assembling methods ..	7	
List of adapter connection shapes	8	
For hydraulic use	LB70/LF70 Series	9
	1000/1100/1400/1500 Series	13
	1000 (Light gray) Series	19
	F3130 (Light gray) Series	21
	N3130/3130/3000 Series	23
	3700 Series	24
	N3000 Series	33
	HT Series	33
	3R80 Series	37
	5501 Series	39
For airless-painting	3450 Series	39
	For clean system	34PW Series

Adapter Products 43

Adapter	43
Adapter shapes chart	44

Hose Guard Parts and Specially-Treated Parts 51

Specially-treated hoses	51
Hose guard parts	53

Hose Assembly Machine Tool, Special Jigs and Tools 55

Hose assembly tools	55
Hose assembly jigs and tools	56

Hose Assembling Methods 57

Campucka couplings	57
Swage coupling (with Mark 10)	59
Swage coupling (with Mark 9)	61
Reusable coupling	67

Technical Document 69

How to select a hose	69
How to determine the hose length ..	71
How to select the hose size for given flow volume and velocity ..	72
Graphs for cubical expansion of hoses ..	73
Tightening torque of hose couplings and adapter	74

Reference Document 75

Technical standard for threads ..	75
Technical standard for plastic hoses ..	77
Table of unit conversion	78
Examples of problems when hose assembly is not used appropriately	79
Chemical resistance list	80

Hydraulic Hose
Airless-painting Hose
Clean Hose
Adapter
Hose Guard Parts, Specially-Treated Parts
Assembling Machine, Jig, Tool
Hose Assembling Method
Technical Document
Reference Document

Precautions for Use

These "Precautions for Use" provide instructions for the correct use of our product to prevent damage to people and property. The instructions are classified into three categories, "danger," "warning," and "caution," depending on the extent of damage from improper use. Every category contains important notes for safety so please follow these as well as ISO 4414-1982 (*1), JIS B 8370 (1988) (*2), ISO4413-1979(*3), and JIS B 8361 (1982) (*4).

(*1) ISO 4414-1982	Pneumatic fluid power... Recommendations for the application of equipment to transmission and control systems.	(*3) ISO 4413-1979	Hydraulic fluid power... General rules for the application of equipment to transmission and control systems.
(*2) JIS B 8370 (1988)	Pneumatic System General Rules	(*4) JIS B 8361 (1982)	Hydraulic System General Rules

DANGER

For the limited cases of inappropriate use, where a dangerous situation leading to death or severe injury is expected and emergent warning is necessary at the occurrence of danger.

WARNING

For the cases of inappropriate use, where a dangerous situation leading to death or severe injury is expected.

CAUTION

For the cases of inappropriate use, where a dangerous situation leading to minor injury or light damage to property is expected.

For more safety information, please read the following carefully.

Notes for each product are also given on the product page. Please read the instructions for use as well.

Notes for the products in this catalog

Notes for the use of Assembling machines Mark 9 and 10 are also given in their instruction manuals.

Before Selection

DANGER

- ① Cannot use for machines and equipment that maintain and control human life.
- ② Cannot use for machines and equipment that require an extremely high level of safety.

WARNING

- ① Designers of instruments, machines, or connecting systems or those who make specifications should consider the handling of our products. In such consideration, a test or analysis should be conducted if necessary. It is their responsibility to assure the given safety and performance of the instruments, the machines, or the systems.
- ② Those who have sufficient knowledge and experience should handle our products.
- ③ Please do not handle and remove our products from instruments, machines, or systems until safety is confirmed.
- ④ Please contact us when using our products in situations and conditions that are not assumed in the specifications described in the catalog.
- ④ Please contact us when using our products for equipment, machines, various types of vehicles, and commercial aircraft, for leisure machines and equipment to transport humans, for medical equipment that would cause human damage if the specifications were inappropriately followed, and for machines in contact with food or drinking water.

When Selecting

WARNING

- ① Please check if the use condition satisfies the "use conditions" in the catalog.
- ② Do not use our products when a caustic or flammable gas is used as a fluid or is in the environment.
- ③ If a gas is used as a fluid, keep the maximum working pressure below 1.0 MPa.
- ④ Do not use our products in places where excessive vibration or impact may occur.
- ⑤ Consult the "Table of chemical resistance" if chemicals are used as a fluid or in the environment.
- ⑥ There is a limited group of hose couplings for each type of hose product. Please select correct combinations according to the specifications.
- ⑦ Our hose products and hose couplings are not compatible with other companies' hose products and hose connectors.
- ⑧ Each type of hose product allows the use of a limited type of fluid. Do not use a fluid that is not allowed.
- ⑨ If use conditions are different between hose products and hose couplings, please use the operating parameters of the lowest rated product as the guideline for all products in use.
- ⑩ The hose product must be of an appropriate size to maintain the necessary flow volume. If the size is not appropriate, the increase in pressure drop and oil temperature could cause problems. The relation of fluid velocity, fluid volume, and hose inner diameter is given in "Nomograph".
- ⑪ When electric insulation is necessary, for example in electrical works, please select "Nonconductive" hoses. Contact Nitta for details.
- ⑫ When electric insulation is particularly required for use, including electrical works, please select "nonconductive" hoses. Contact Nitta for details.

CAUTION

- ① When water or glycol-type operating oil is used, hoses work without problem but some plated types of hose couplings cannot be used. Contact Nitta for details.
- ② Hose products might change their length by $\pm 3\%$ under pressure, so do not stretch hoses tightly.
- ③ Gas, liquid or solid components may leak from tubes or couplings. These quantities vary depending on the material and use conditions. If there is a possibility of causing a problem in use, check the material and use conditions before use.

Disclaimer

- ① Nitta shall not be liable for any loss or damage caused by an accident attributable to Customer's negligence or willful misconduct, or attributable to a failure of other company's product (including software malfunction), or by a natural disaster.
- ② Nitta shall not be liable for any loss or damage caused by use not described or not specified in this catalog (including the instruction manuals).
- ③ Nitta shall not be liable for a failure arising from the contents of an inquiry to Nitta unless there is a definite record showing that Nitta is responsible for the failure.
- ④ Nitta shall not be liable for any incidental loss or damage (including a loss of business profits and business interruption) arising from the use of Nitta's product or inability to use Nitta's product.

When Installing

WARNING

- ① Instructions for connecting hoses are given in a separate document. Please read it and follow the instructions for installation.
- ② Do not use couplings with damaged threads and seat surface.
- ③ If you use reusable products such as reusable couplings, ensure that they are not damaged.
- ④ We will not guarantee any products which are additionally treated, disassembled or refabricated by others.
- ⑤ For installation of hoses, please assemble them in a place where unexpected disconnection of hose and couplings cannot cause damage to people or property.

CAUTION

- ① Prevent damaging the hoses, e.g. entanglement or abrasion. It could cause flattening, destruction, and disconnection.
- ② Install hoses to prevent loads such as tension, torsion, rotation, and bending with a radius under the minimum bend radius.
- ③ Do not break a hose, which might cause "fatigue destruction" at the break point even under the maximum working pressure.
- ④ When the plug-in part of the hose couplings is dirty, clean the surface.
- ⑤ Do not use hoses if they have a dent or damage.
- ⑥ Do not twist hose assemblies after pressure is applied. When they are twisted, it could deform the inner structure of the hoses and result in destruction.
- ⑦ Do not throw and drop hose couplings, which might damage threads and sheets and lead to oil leakage.
- ⑧ Tighten the hose coupling to the specified torque. Some material may expand or crack by the tightening, so check and confirm the strength of the part to be assembled.
- ⑨ Sharply bending a hose near the coupling could shorten the life of the hose. When bending a hose, keep the hose straight of the length longer than the outer diameter of the hose from the assembled part.
- ⑩ Pressure on hose products could cause interference with surrounding parts on which no interference exists before the pressure is applied. Please handle appropriately, e.g. introducing guard parts.
- ⑪ Do not over-tighten when using clamps such as INSULOK ties to assemble a hose. Concentrated stress may cause "fatigue destruction".
- ⑫ Hose products are designed to withstand inner pressure, so do not apply outer pressure to them.
- ⑬ You cannot reuse hoses and hose couplings except reusable couplings.
- ⑭ Protect a hose from possible outer damage by using a wire braid or guard spring.
- ⑮ If hoses are left bent over a certain period of time, they will retain their new shape. When removing and reinstalling a hose assembly for machine exchange, circuit inspection, repair, and so forth, please attach the hose in the original position. When attaching it, clean the threads and seat of the coupling and tighten it to the specified torque.

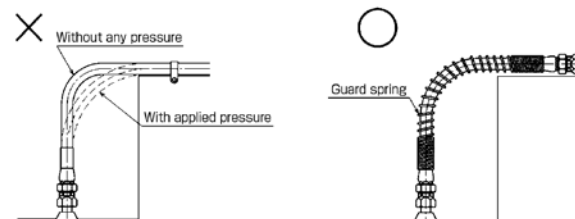
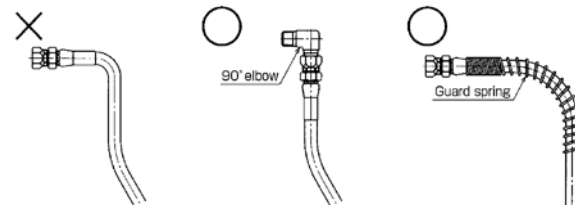
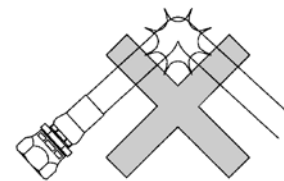
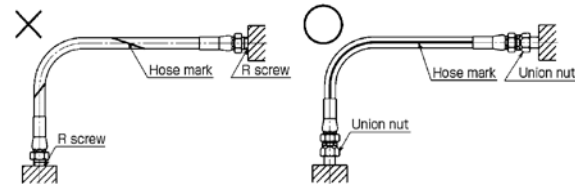

When Using

WARNING

- ① Do not touch hose products during pressurization. If you improperly approach or touch a hose during pressurization could be quite dangerous if an unexpected breakage of the hose or the coupling were to scatter fluid inside.
- ② Do not touch hose products when the fluid is hot. It could cause a burn.
- ③ When water is used as a fluid, please keep it unfrozen.

When Storing

CAUTION

- ① If you store unused products, keep them in a clean place to prevent dust. When fine particles such as dust enter the inside, they also enter the connecting equipment and may cause problems.
- ② Keep hose products in a dry place under 40°C avoiding direct sunlight.
- ③ Store a hose in a straight position or in a coil with a larger diameter than the minimum bend diameter.
- ④ Try to use hoses and couplings within about one year after production.

When Maintaining

CAUTION

- ① Please conduct periodic inspection. Confirm that there is no degradation such as outer damage, corrosion, and abrasion as well as any distorted parts and replace if necessary.
- ② Change the hose immediately if the outer damage or abrasion reaches, or is about to reach, the synthetic fiber braid.

Hose products

How to Order Hose Assembly

Check the following usage conditions before ordering

- 1 Type and volume of working fluid
- 2 Working pressure (maximum working pressure : MPa)
- 3 Working temperature range (temperature of fluid and environment : °C)
- 4 Bending radius of hose (minimum bending radius : mm)

Based on the above conditions, please follow the steps below

- 1 Select the type of hose (A) and the inner diameter (D).
- 2 Indicate the length (L) of hose assembly. (Use the length between the edges of two couplings.)
- 3 Select types and materials of couplings (B and C) and adapter (E).
- 4 Specify if guard spring (F) are required. See P.53 for accessories.

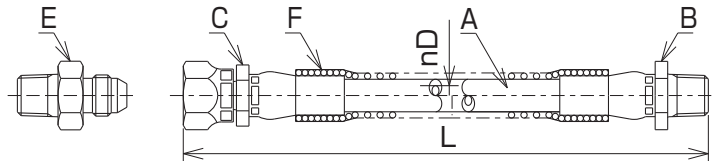

Hose selection table

				Hydraulic Piping							
Page				9		13			19	21	
Hose series				LB70	LF70	1000	1100	1400	1500	1000 (Light gray)	F3130 (Light gray)
Size	I.D.(in.)	I.D.(mm)									
02	1/8	3.6	Max. working pressure (MPa)	7.0	-	-	-	-	-	-	20.0
03	3/16	4.8		-	-	-	-	15.0	-	-	-
04	1/4	6.3		7.0	7.0	10.5	10.5	14.0	-	10.5	19.5
05	5/16	7.9		-	-	-	-	-	-	-	-
06	3/8	9.5		7.0	7.0	10.5	10.5	14.0	-	10.5	16.0
08	1/2	12.7		7.0	7.0	10.5	10.5	-	-	10.5	14.0
10	5/8	15.9		7.0	-	-	-	-	-	-	-
12	3/4	19.0		7.0	-	-	-	-	-	-	9.0
16	1	25.4		7.0	-	-	-	-	-	-	7.0
Temp. range (°C)				-40 to +100 (16 sizes only -40 to +70)	-40 to +100	-40 to +100 (for Campucka -20 to +100)	-40 to +100	-40 to +100 (for Campucka -20 to +100)	-40 to +100	-40 to +100 (for Campucka -20 to +100)	-40 to +100 (for Campucka -20 to +100)
Features				Super flexible, small bend radius	Super flexible, small bend radius	Thin, light, Campucka usable	Outer wire braid	Thin, light	Thin, light	Thin, light, Campucka usable	Flexible, Campucka usable
Application				<ul style="list-style-type: none"> ● Machine tools ● General operating machine, etc. 	<ul style="list-style-type: none"> ● Construction machine ● General operating machine, etc. 	<ul style="list-style-type: none"> ● Construction machine ● Farming machine ● Machine tools, etc. 	<ul style="list-style-type: none"> ● Machine tools, etc. 	<ul style="list-style-type: none"> ● Industrial vehicles ● Farming machine, etc. 	<ul style="list-style-type: none"> ● Industrial vehicles ● Farming machine, etc. 	<ul style="list-style-type: none"> ● Oil pressure of machine tools ● Coolant piping 	<ul style="list-style-type: none"> ● Oil pressure of machine tools

*1 Matched to type A of JIS K 6375 (hydraulic braid-reinforced plastic hose), matched to SAE100R7.
 *2 Matched to type B of JIS K 6375 (hydraulic braid-reinforced plastic hose), matched to SAE100R8.
 *3 Nonconductive (electrically insulative). See P.51 for details.

N3130-04 1000L SAXSE+010-G1

A Type of hose

D Inner diameter of hose

L Length of hose assembly

B Type of one coupling

C Types of the other couplings

F Fitting shape of guard parts

(Ex) Below are the types of guard springs

G1 : Full length

G2 : Both ends

(Please specify the length)

G3 : Single end

(Please specify the length and the direction of installation)

E Types of adapter

Length tolerance of hose assembly

The length tolerances of hose assemblies conform to JIS B 8362.

Length of hose assembly	Length tolerance
Less than 500 L	+10L -0L
500 L to less than 1000 L	+15L -0L
1000 L to less than 2000 L	+20L -0L
2000 L to less than 5000 L	+1.0% -0L
5000 L or more	+2.0% -0L

Hydraulic Piping							For Airless-painting		For Clean Use		
	23			24	33		37	39		41	Page
	^{*1} ^{*3} N3130	3130	3000	^{*1} 3700	N3000	HT	^{*2} ^{*3} 3R80	5501	3450 (Made-to-order)	34PW	Hose series
											Size
	-	20.0	-	-	-	-	-	-	-	20.0	02
	21.0	20.0	34.0	21.0	-	-	35.0	-	23.0	-	03
	19.5	20.0	30.0	19.5	28.0	28.0	35.0	21.0	23.0	19.5	04
	17.5	18.0	-	-	-	-	-	-	-	-	05
	16.0	18.0	24.0	16.0	21.0	21.0	28.0	21.0	21.0	16.0	06
	14.0	16.0	20.0	14.0	21.0	21.0	25.0	-	-	14.0	08
	-	-	-	-	17.5	17.5	-	-	-	-	10
	9.0	10.0	13.0	-	-	-	16.0	-	-	10.5	12
	7.0	-	10.0	-	-	-	14.0	-	-	10.5	16
	-40 to +100	-40 to +100	-40 to +100	-55 to +100	-40 to +100	-40 to +120	-40 to +100	-10 to +60	-40 to +80	-30 to +70	Temp. range (°C)
	Flexible	Reusable coupling usable	Reusable coupling usable	Eco-friendly	Flexible	Flexible, for high temp oil	High pressure	Painting (SUS braid)	Painting, light (conductive resin)	Pure water, chemicals	Features
	<ul style="list-style-type: none"> ● Machine tools ● Industrial vehicles ● General operating machine ● Robot ● Utility piping in factory, etc. 	<ul style="list-style-type: none"> ● General industrial machine, etc. 	<ul style="list-style-type: none"> ● General industrial machine, etc. 	<ul style="list-style-type: none"> ● Industrial vehicle, etc. 	<ul style="list-style-type: none"> ● Construction machine ● Industrial vehicle ● Injection molding machine ● Hose reel, etc. 	<ul style="list-style-type: none"> ● Construction machine ● Industrial vehicle ● Injection molding machine ● Hose reel, etc. 	<ul style="list-style-type: none"> ● Construction machine ● Hydraulic press, etc. 	<ul style="list-style-type: none"> ● Airless painting machine, etc. 	<ul style="list-style-type: none"> ● Airless painting machine, etc. 	<ul style="list-style-type: none"> ● Facility in clean room ● Urethane coating ● Cesalination equipment, etc. 	Application

Hydraulic hose products

Hydraulic Hose

Airless-painting Hose

Clean Hose

Adapter

Hose Guard Parts, Specially-Treated Parts

Assembling Machine, Jig, Tool

Hose Assembling Method

Technical Document

Reference Document

Hose products

Types of hose couplings for hose-assembling methods

Push-one type

Campucka



The Campucka coupling enables push-one connection in the hose-coupling assembling without any swaging machine, the on-site assembling can be performed easily without fail.

Cross-sectional structure diagram

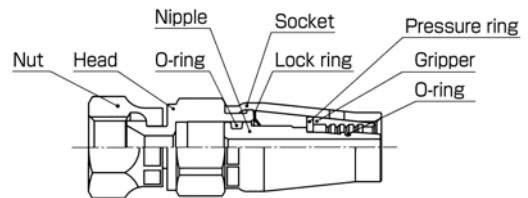

Assembling method
▶▶▶ p.57

Swaging type

Swage



The swage coupling is attached to the hose by swaging. The coupling and the hose can be easily swaged (assembled) with a manual assembling tool [Mark10], or a hydraulic assembling machine [Mark9].

Some couplers and hoses have to be assembled in our factory.

Cross-sectional structure diagram

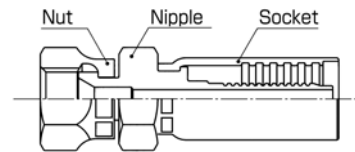

Assembling method
▶▶▶ p.59

Compression type

Reusable



The reusable coupling is used to screw in a hose. On-site assembling is possible and the detached coupling is reusable.

Cross-sectional structure diagram

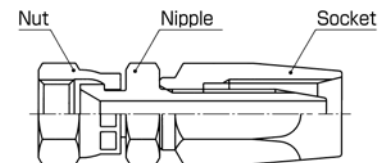

Assembling method
▶▶▶ p.65

List of hose connection shapes

Example of part number

SE-PF-04-(N30)-(S)

Type and shape of coupling see below	Thread type PT (R) PF (G) NPSM UNF (Only size is shown)	Hose size		Hose part number	
		02 = 1/8" 03 = 3/16" 04 = 1/4" 05 = 5/16" 06 = 3/8"	08 = 1/2" 10 = 5/8" 12 = 3/4" 16 = 1"	14 = 1000, 1100, 1400, 1500 N30 = N3000, HT 55 = 5501 PW = 34PW	No indication = N3130, 3130, 3700, 3000

Material
 No indication = steel
 Surface finishing
 (Campucka and Swage types: zinc electrogalvanized with color chromating (Ep-Fe/Zn5/CM2))
 (Reusable type: zinc electrogalvanized with color chromating (Ep-Fe/Zn5/CM1))
 F-type nipple is processed by zinc galvanization with color chromating.
 S = SUS304
 S6 = SUS316
 PW = SUS316 for 34PW hose

Tapered male-thread coupling

- SA** (Swage)
- A** (Reusable)
- CA** (Campucka)

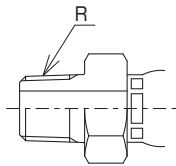

O-ring port coupling with parallel male-thread

- SO** (Swage)

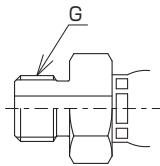

Parallel male-thread coupling (with 30° female seat)

- SC** (Swage)

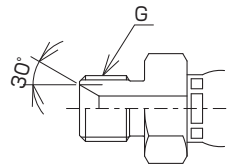

Parallel female-thread union coupling (with 30° female seat)

- SE** (Swage)
- E** (Reusable)
- CE** (Campucka)

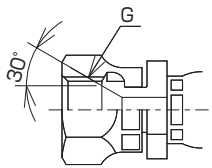

Parallel female-thread union coupling (with 30° male seat)

- SF** (Swage)
- F** (Reusable)
- CF** (Campucka)

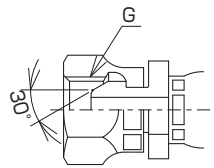

Unified female-thread union coupling (with 37° female seat)

- SK** (Swage)

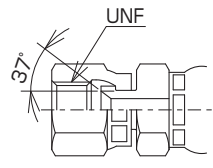

Unified female-thread ORFS union coupling

- SGS** (Swage)

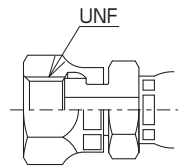

MADE TO ORDER
Contact us for details

Parallel female-thread union 90° elbow coupling (with 30° female seat)

- SLE** (Swage)

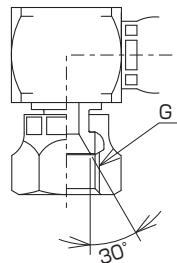

MADE TO ORDER
Contact us for details

Parallel female-thread union 90° elbow coupling (with 30° male seat)

- SL** (Swage)

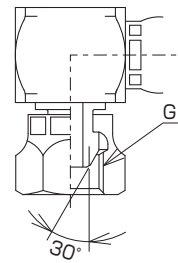

Unified external-thread union 90° elbow coupling (with 37° female seat)

- SLK** (Swage)

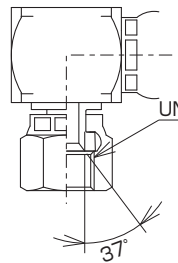

MADE TO ORDER
Contact us for details

Unified female-thread ORFS union 90° elbow coupling

- SLG** (Swage)

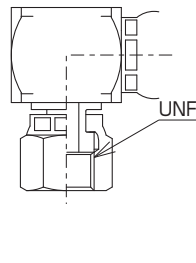

MADE TO ORDER
Contact us for details

Parallel female-thread union bend coupling (with 30° female seat)

- AE*** (Swage)
- SE** (Swage)

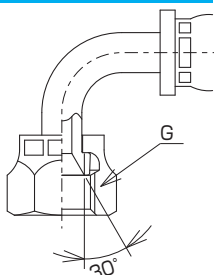

Parallel female-thread union bend coupling (with 30° male seat)

- AF*** (Swage)
- SF** (Swage)

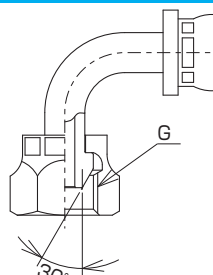

Unified female-thread union bend coupling (with 37° female seat)

- AK*** (Swage)

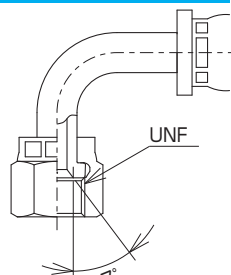

MADE TO ORDER
Contact us for details

Unified female-thread ORFS union bend coupling

- AG*** (Swage)

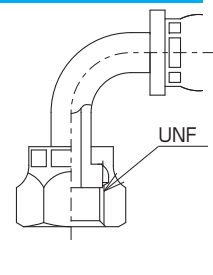

MADE TO ORDER
Contact us for details

The mark * at the part number of the union bend indicates the angle and select 45° or 90°.

- Hydraulic Hose
- Airless-painting Hose
- Clean Hose
- Adapter
- Hose Guard Parts, Specially-Treated Parts
- Assembling Machine, Jig, Tool
- Hose Assembling Method
- Technical Document
- Reference Document

Hose products

LB70-LF70 Series

LB70

Features

- Improved flexibility by 15-25% (compared to our other equivalent types)
- High abrasion resistance
- Short total length of coupling enables compact piping

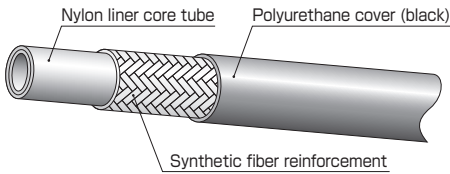

Part No.	Size			Max. working pressure		Min. burst pressure		Min. bending radius (mm)	Weight (g/m)	Coupling
	Size No.	I.D. (in.)	O.D. (mm)	(MPa)	(PSI)	(MPa)	(PSI)			
LB70-02	02	1/8	3.6	7.5	7.0	1,000	28.0	4,000	10	Swage
LB70-04	04	1/4	6.4	10.5	7.0	1,000	28.0	4,000	27	
LB70-06	06	3/8	9.5	13.9	7.0	1,000	28.0	4,000	45	
LB70-08	08	1/2	12.7	17.4	7.0	1,000	28.0	4,000	70	
★ LB70-10	10	5/8	15.9	22.8	7.0	1,000	28.0	4,000	100	
LB70-12	12	3/4	19.2	26.6	7.0	1,000	28.0	4,000	130	
LB70-16	16	1	25.7	33.4	7.0	1,000	28.0	4,000	165	

- Appropriate fluid : mineral general operating oil
- Working temperature range : -40 to +100°C (16 sizes only -40~+70°C)
- Length in a unit package : 100m for sizes 02, 04, 06, 08, and 50m for sizes 10, 12, 16

★Made-to-order

Flexibility test

Starting from a 180° bend, bending radius of hose is gradually decreased on test equipment to compare bending radius against bending force.

<Test conditions>
 Test speed : 100mm/min
 Temperature : 23°C

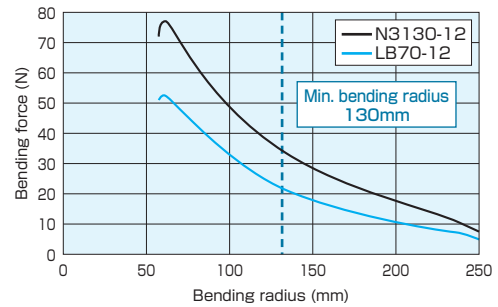
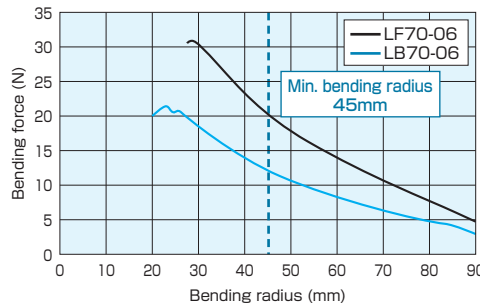

Wear test (grindstone)

The weight of a 150mm length of hose is measured after one week in a room with constant temperature and humidity. Then, the hose is placed onto testing equipment, held by a rod at the bottom, with a grinding stone against the upper surface. The hose is subjected to a set number of wear cycles, after which it is again weighed (following a one week period in a room with constant temperature and humidity). The changes to the hose after testing are then examined to form a wear comparison.

<Test conditions>
 Test load : 2.5kg Temperature : Room temperature (23°C) Stroke : 100mm
 Cycle : 20 times (RT)/min Grind stone : Grinding wheel for taper wear H-22 (particle size : Approx. 60)

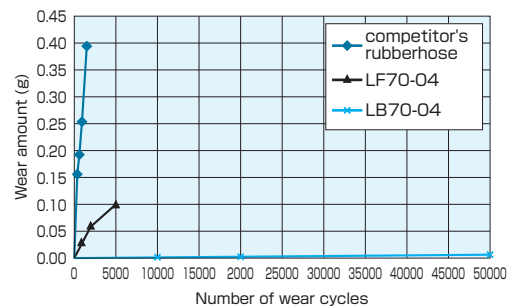

LF70

Features

- Short total length of coupling enables compact piping

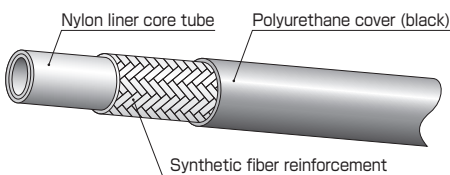

Part No.	Size			Max. working pressure		Min. burst pressure		Min. bending radius (mm)	Weight (g/m)	Coupling
	Size No.	I.D. (in.)	O.D. (mm)	(MPa)	(PSI)	(MPa)	(PSI)			
LF70-04	04	1/4	6.4	10.3	7.0	1,000	28.0	4,000	27	Swage
LF70-06	06	3/8	9.5	13.9	7.0	1,000	28.0	4,000	45	
LF70-08	08	1/2	12.7	17.4	7.0	1,000	28.0	4,000	70	

- Appropriate fluid : mineral general operating oil
- Working temperature range : -40 to +100°C
- Length in a unit package : 100m

[Swage type]

(For LB70, LF70)

SA

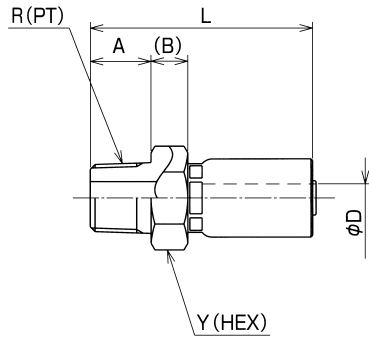

Part No.	Size No.	R	A	B	Min. I.D. φD	L	Y (HEX)	Weight (g)	Pusher	Die
SSA-PT-02	02	1/8	10	6.5	1.8	38	14	15	PSA-02	SPLB70-02
SA-PT-04-14	04	1/4	13	8.5	3.5	50	19	43	PSA-04	SP14-04-07
SA-PT-06-14	06	3/8	15	9.0	6.8	54	22	72	PSA-06	SP14-06-07
SA-PT-08-14	08	1/2	18	10.0	9.5	61	27	115	PSA-08	SP14-08
SA-PT-10-N30	10	3/4	20	10.0	13.0	80	32	180	PSA-10	SP07-10
SA-PT-12	12	3/4	20	10.0	16.0	82	36	220	PSA-12	SP3-12
SA-PT-16	16	1	23	10.0	20.9	100	41	340	PSA-16	SP07-16

■ Material : steel
 ■ Adapter : 030, 130

SE

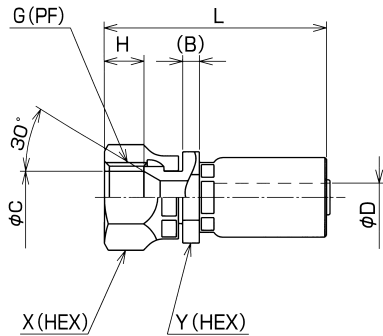

Part No.	Size No.	G	B	C	Min. I.D. φD	H	L	X (HEX)	Y (HEX)	Weight (g)	Pusher	Die
SSE-PF-02	02	1/8	4.0	6.8	1.8	7.0	42	14	14	25	PSE-02-001	SPLB70-02
SE-PF-04-14	04	1/4	4.0	9.3	3.5	8.0	49	19	17	55	PSE-14-04	SP14-04-07
SE-PF-06-14	06	3/8	4.0	12.3	6.8	9.5	53	22	19	75	PSE-14-06	SP14-06-07
SE-PF-08-14	08	1/2	4.5	16.0	9.5	12.0	61	27	24	125	PSE-14-08	SP14-08
SE-PF-10-N30	10	3/4	10.5	21.0	13.1	13.0	84	32	32	220	PSE-10	SP07-10
SE-PF-12	12	3/4	10.5	21.5	16.0	13.0	87	36	36	280	PSE-12	SP3-12
SE-PF-16	16	1	11.0	27.5	20.9	15.0	105	41	41	400	PSE-16	SP07-16

■ Material : steel
 ■ Adapter : 010, 045, 090, 150, 020, 025, 064, 069, 030

SF

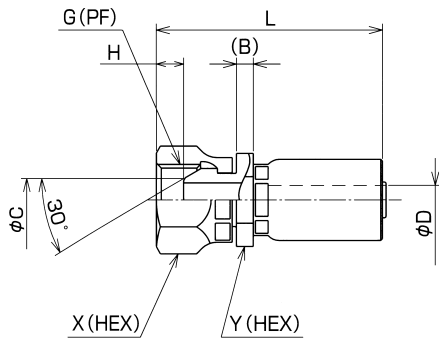

Part No.	Size No.	G	B	C	Min. I.D. φD	H	L	X (HEX)	Y (HEX)	Weight (g)	Pusher	Die
SSF-PF-02	02	1/8	4.0	5.0	1.8	3.0	41	14	14	25	PSE-02-001	SPLB70-02
SF-PF-04-14	04	1/4	4.0	7.5	3.5	5.5	49	19	17	55	PSE-14-04	SP14-04-07
SF-PF-06-14	06	3/8	4.0	10.0	6.8	6.5	53	22	19	75	PSE-14-06	SP14-06-07
SF-PF-08-14	08	1/2	4.5	13.2	9.5	9.0	61	27	24	125	PSE-14-08	SP14-08
SF-PF-10-N30	10	3/4	10.5	19.0	13.1	9.5	84	32	32	220	PSE-10	SP07-10
SF-PF-12	12	3/4	10.5	19.0	16.0	9.5	87	36	36	280	PSE-12	SP3-12
SF-PF-16	16	1	11.0	25.4	20.9	10.0	105	41	41	410	PSE-16	SP07-16

■ Material : steel
 ■ Adapter : 110, 145, 190, 130

Hydraulic Hose products

- Hydraulic Hose
- Airless-painting Hose
- Clean Hose
- Adapter
- Hose Guard Parts, Specially-Treated Parts
- Assembling Machine, Jig, Tool
- Hose Assembling Method
- Technical Document
- Reference Document

Hose products

[Swage type]

(For LB70, LF70)

AE45

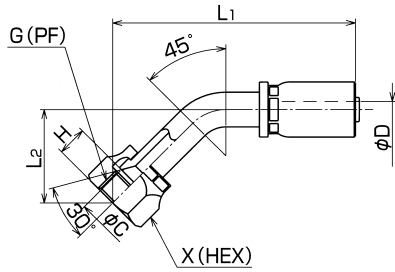

Part No.	Size No.	G	C	Min. I.D. ϕD	H	L ₁	L ₂	X (HEX)	Weight (g)	Pusher	Die
AE45-G-04-14	04	1/4	9.0	3.2	8.0	61	18	19	57	PFB-01+PA-04	SP14-04-07
AE45-G-06-14	06	3/8	12.0	5.6	9.5	74	25	22	90	PFB-01+PA-06	SP14-06-07
AE45-G-08-14	08	1/2	15.5	8.7	12.0	87	29	27	143	PFB-01+PA-08	SP14-08

- Material : steel
- Adapter : 010, 045, 090, 150, 020, 025, 064, 069, 030

AE90

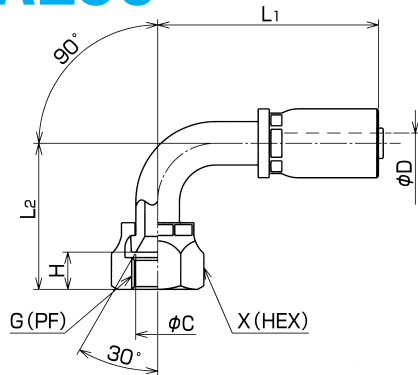

Part No.	Size No.	G	C	Min. I.D. ϕD	H	L ₁	L ₂	X (HEX)	Weight (g)	Pusher	Die
AE90-G-04-14	04	1/4	9.0	3.2	8.0	51	33	19	59	PFB-01+PA-04	SP14-04-07
AE90-G-06-14	06	3/8	12.0	5.6	9.5	61	45	22	98	PFB-01+PA-06	SP14-06-07
AE90-G-08-14	08	1/2	15.5	8.7	12.0	68	52	27	153	PFB-01+PA-08	SP14-08

- Material : steel
- Adapter : 010, 045, 090, 150, 020, 025, 064, 069, 030

AF45

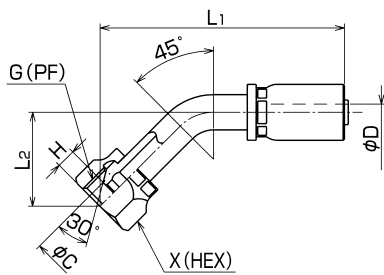

Part No.	Size No.	G	C	Min. I.D. ϕD	H	L ₁	L ₂	X (HEX)	Weight (g)	Pusher	Die
AF45-G-04-14	04	1/4	7.0	3.2	5.5	63	19	19	58	PFB-01+PA-04	SP14-04-07
AF45-G-06-14	06	3/8	10.0	5.6	6.5	72	23	22	90	PFB-01+PA-06	SP14-06-07
AF45-G-08-14	08	1/2	14.0	8.7	9.0	88	30	27	147	PFB-01+PA-08	SP14-08

- Material : steel
- Adapter : 110, 145, 190, 130

AF90

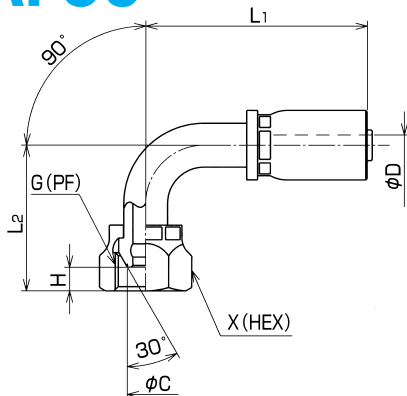

Part No.	Size No.	G	C	Min. I.D. ϕD	H	L ₁	L ₂	X (HEX)	Weight (g)	Pusher	Die
AF90-G-04-14	04	1/4	7.0	3.2	5.5	51	33	19	61	PFB-01+PA-04	SP14-04-07
AF90-G-06-14	06	3/8	10.0	5.6	6.5	61	45	22	100	PFB-01+PA-06	SP14-06-07
AF90-G-08-14	08	1/2	14.0	8.7	9.0	68	52	27	156	PFB-01+PA-08	SP14-08

- Material : steel
- Adapter : 110, 145, 190, 130

Hydraulic Hose	Airless-painting Hose	Clean Hose	Adapter	Hose Guard Parts, Specially-Treated Parts	Assembling Machine, Jig, Tool	Hose Assembling Method	Technical Document	Reference Document
----------------	-----------------------	------------	---------	---	-------------------------------	------------------------	--------------------	--------------------

Hose products

1000-1100-1400-1500 Series

1000

Features

- Small outer diameter
- Lightweight
- Campucka coupling can be used

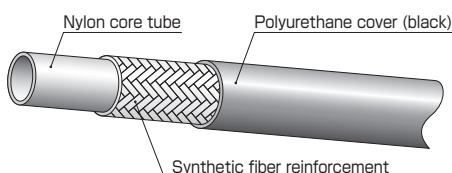

Part No.	Size			Max. working pressure		Min. burst pressure		Min. bending radius (mm)	Weight (g/m)	Coupling	
	Size No.	I.D. (in.)	I.D. (mm)	O.D. (mm)	(MPa)	(PSI)	(MPa)				(PSI)
1000-04	04	1/4	6.3	10.4	10.5	1,500	42.0	6,000	30	64	Campucka Swage
1000-06	06	3/8	9.5	14.0	10.5	1,500	42.0	6,000	60	90	
1000-08	08	1/2	12.7	17.4	10.5	1,500	42.0	6,000	80	131	

- Appropriate fluid : mineral general operating oil
- Working temperature range : -40 to +100°C
- Length in a unit package : 100m

1100

Features

- Outer wire reinforcement prevents the cutting powder

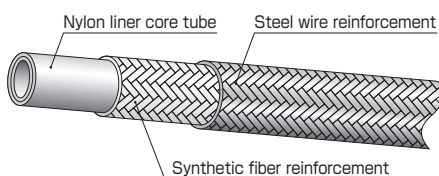

Part No.	Size			Max. working pressure		Min. burst pressure		Min. bending radius (mm)	Weight (g/m)	Coupling	
	Size No.	I.D. (in.)	I.D. (mm)	O.D. (mm)	(MPa)	(PSI)	(MPa)				(PSI)
1100-04	04	1/4	6.3	11.1	10.5	1,500	42.0	6,000	40	150	Swage
1100-06	06	3/8	9.5	15.1	10.5	1,500	42.0	6,000	60	220	
1100-08	08	1/2	12.7	18.8	10.5	1,500	42.0	6,000	80	300	

- Appropriate fluid : mineral general operating oil
- Working temperature range : -40 to +100°C
- Length in a unit package : 100m

1400

Features

- Small outer diameter
- Lightweight
- Campucka coupling can be used

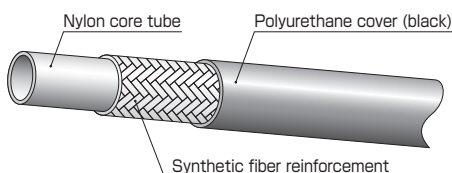

Part No.	Size			Max. working pressure		Min. burst pressure		Min. bending radius (mm)	Weight (g/m)	Coupling	
	Size No.	I.D. (in.)	I.D. (mm)	O.D. (mm)	(MPa)	(PSI)	(MPa)				(PSI)
1400-04	04	1/4	6.3	10.4	14.0	2,000	56.0	8,000	30	64	Campucka Swage
1400-06	06	3/8	9.5	14.0	14.0	2,000	56.0	8,000	60	90	

- Appropriate fluid : mineral general operating oil
- Working temperature range : -40 to +100°C
- Length in a unit package : 100m

1500

Features

- Small outer diameter
- Lightweight

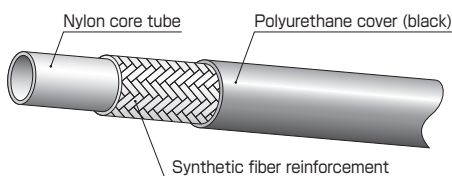

Part No.	Size			Max. working pressure		Min. burst pressure		Min. bending radius (mm)	Weight (g/m)	Coupling	
	Size No.	I.D. (in.)	I.D. (mm)	O.D. (mm)	(MPa)	(PSI)	(MPa)				(PSI)
1500-03	03	3/16	5.1	8.8	15.0	2,150	60.0	8,600	20	45	Swage

- Appropriate fluid : mineral general operating oil
- Working temperature range : -40 to +100°C
- Length in a unit package : 100m

[Campucka type] Hydraulic push-one coupling (For 1000, 1400)

CA

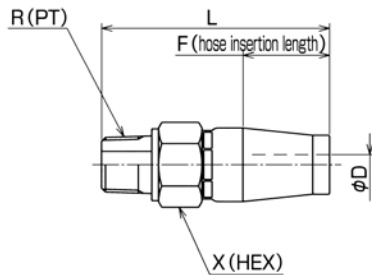

Part No.	R	Min. I.D. φD	F	L	X	Weight (g)
CA-R-04-14L	1/4	3.5	26.0	60	19	70
CA-R-06-14L	3/8	6.0	29.0	68	22	100
CA-R-08-14L	1/2	9.0	35.0	77	27	170

⚠ CAUTION : Handle with care not to drop couplings as an inner nipple could be self locked by pushing-out action to inlet of coupling.

- Material : steel
- Working temperature range : -20 to +100°C
- Adapter : 030, 130

CE

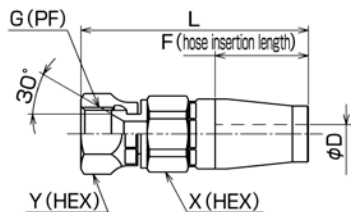

Part No.	G	Min. I.D. φD	F	L	X	Y	Weight (g)
CE-G-04-14L	1/4	3.5	26.0	64	19	19	85
CE-G-06-14L	3/8	6.0	29.0	72	22	22	115
CE-G-08-14L	1/2	9.0	35.0	83	27	27	205

⚠ CAUTION : Handle with care not to drop couplings as an inner nipple could be self locked by pushing-out action to inlet of coupling.

- Material : steel
- Working temperature range : -20 to +100°C
- Adapter : 010, 045, 090, 150, 020, 025, 064, 069, 030

CF

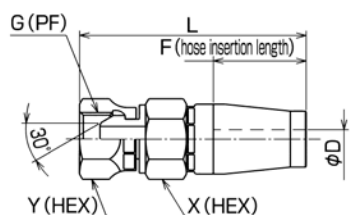

Part No.	G	Min. I.D. φD	F	L	X	Y	Weight (g)
CF-G-04-14L	1/4	3.5	26.0	64	19	19	85
CF-G-06-14L	3/8	6.0	29.0	72	22	22	115
CF-G-08-14L	1/2	9.0	35.0	83	27	27	205

⚠ CAUTION : Handle with care not to drop couplings as an inner nipple could be self locked by pushing-out action to inlet of coupling.

- Material : steel
- Working temperature range : -20 to +100°C
- Adapter : 110, 145, 190, 130

Features of Campucka and assembly mechanism

Assembling method ▶▶▶ p.57

1 Push-one connection

- Reduction of operation time (half that of our conventional product)
- Specialized swaging tool is not necessary. (Easy handling)
- Best for on-site length adjustment.
- Convenient for emergency repair.

2 Detachable hose

- Hose is detachable for length adjustment when piping.
 - Detachable tool is available.
- ⚠ CAUTION : Cannot be detached after pressurization.

3 Correcting hose's twisted direction

- It is possible to correct the twisted direction of a hose.
- ⚠ CAUTION : Cannot be detached after pressurization.

4 Nipple stop mechanism

- Ratchet mechanism of our original lock ring is employed.
- Steady performance even for movable piping.
- Pressure variation is accommodated.

Campucka assembly mechanism

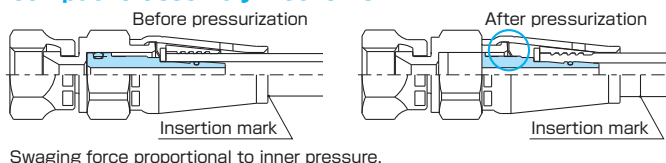

Detailed diagram



Lock ring prevents swage releasing after pressurization.

⚠ CAUTION : Handle with care not to drop couplings as an inner nipple could be self locked by pushing-out action to inlet of coupling.

Hydraulic Hose

Airless-painting Hose

Clean Hose

Adapter

Hose Guard Parts, Specially-Treated Parts

Assembling Machine, Jig, Tool

Hose Assembling Method

Technical Document

Reference Document

Hose products

[Swage type]

(For 1000, 1100, 1400, 1500)

SA

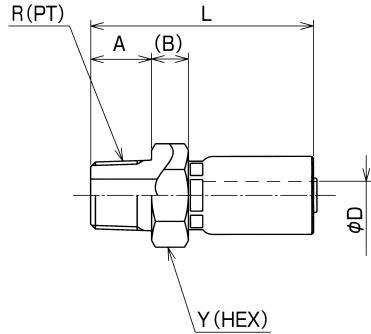

Part No.	Size No.	R	A	B	Min. I.D. φD	L	Y (HEX)	Weight (g)	Pusher	Die
SA-PT-03-14	03	1/4	13	8.5	3.0	44	19	40	PSA-04	SP14-03
SA-PT-04-14	04	1/4	13	8.5	3.5	50	19	43	PSA-04	SP14-04
SA-PT-06-14	06	3/8	15	9.0	6.8	54	22	72	PSA-06	SP14-06
SA-PT-08-14	08	1/2	18	10.0	9.5	61	27	115	PSA-08	SP14-08* SP10-08*

■ Material : steel
 ■ Adapter : 030, 130
 * Use SP-14-08 for 1000-08 and SP-10-08 for 1100-08.

Stainless steel type

Part No.	Size No.	R	A	B	Min. I.D. φD	L	Y (HEX)	Weight (g)	Pusher	Die	
										First	Second
SA-PT-04-14-S	04	1/4	13	8.5	3.5	50	19	43	PSA-04	SPH-03	SP14-04
SA-PT-06-14-S	06	3/8	15	9.0	6.8	54	22	72	PSA-06	SP3-05-1-ST	SP14-06
SA-PT-08-14-S	08	1/2	18	10.0	9.5	61	27	115	PSA-08	SPH-06-1-ST	SP14-08

■ Material : stainless steel SUS304
 ■ Adapter : 030, 130

SE

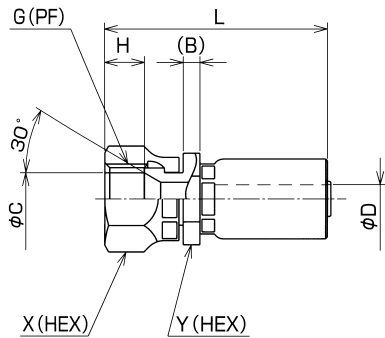

Part No.	Size No.	G	B	C	Min. I.D. φD	H	L	X (HEX)	Y (HEX)	Weight (g)	Pusher	Die
SE-PF-03-14	03	1/4	4.0	9.5	3.0	8.0	44	19	17	42	PSE14-04	SP14-03
SE-PF-04-14	04	1/4	4.0	9.3	3.5	8.0	49	19	17	55	PSE14-04	SP14-04
SE-PF-06-14	06	3/8	4.0	12.3	6.8	9.5	53	22	19	75	PSE14-06	SP14-06
SE-PF-08-14	08	1/2	4.5	16.0	9.5	12.0	61	27	24	125	PSE14-08	SP14-08* SP10-08*

■ Material : steel
 ■ Adapter : 010, 045, 090, 150, 020, 025, 064, 069, 030
 * Use SP-14-08 for 1000-08 and SP-10-08 for 1100-08.

Stainless steel type

Part No.	Size No.	G	B	C	Min. I.D. φD	H	L	X (HEX)	Y (HEX)	Weight (g)	Pusher	Die	
												First	Second
SE-PF-04-14-S	04	1/4	4.0	9.5	3.5	8.0	49	19	17	55	PSE-14-04	SPH-03	SP14-04
SE-PF-06-14-S	06	3/8	4.0	12.5	6.8	9.5	53	22	19	71	PSE-14-06	SP3-05-1-ST	SP14-06
SE-PF-08-14-S	08	1/2	4.5	16.0	9.5	12.0	61	27	24	125	PSE-14-08	SPH-06-1-ST	SP14-08

■ Material : stainless steel SUS304
 ■ Adapter : 010, 045, 090, 150, 020, 025, 064, 069, 030

SF

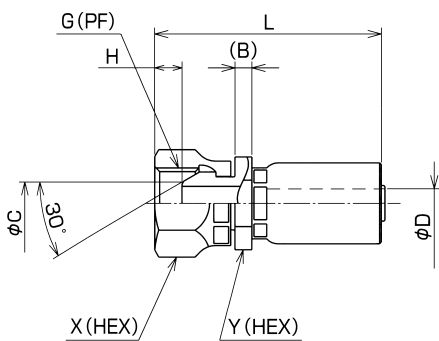

Part No.	Size No.	G	B	C	Min. I.D. φD	H	L	X (HEX)	Y (HEX)	Weight (g)	Pusher	Die
SF-PF-03-14	03	1/4	4.0	7.5	3.0	5.5	44	19	17	45	PSE14-04	SP14-03
SF-PF-04-14	04	1/4	4.0	7.5	3.5	5.5	49	19	17	55	PSE14-04	SP14-04
SF-PF-06-14	06	3/8	4.0	10.0	6.8	6.5	53	22	19	75	PSE14-06	SP14-06
SF-PF-08-14	08	1/2	4.5	13.2	9.5	9.0	61	27	24	125	PSE14-08	SP14-08* SP10-08*

■ Material : steel
 ■ Adapter : 110, 145, 190, 130
 * Use SP-14-08 for 1000-08 and SP-10-08 for 1100-08.

Stainless steel type

Part No.	Size No.	G	B	C	Min. I.D. φD	H	L	X (HEX)	Y (HEX)	Weight (g)	Pusher	Die	
												First	Second
SF-PF-04-14-S	04	1/4	4.0	7.5	3.5	5.5	49	19	17	56	PSE-14-04	SPH-03	SP14-04
SF-PF-06-14-S	06	3/8	4.0	10.0	6.8	6.5	53	22	19	75	PSE-14-06	SP3-05-1-ST	SP14-06
SF-PF-08-14-S	08	1/2	4.5	13.2	9.5	9.0	61	27	24	125	PSE-14-08	SPH-06-1-ST	SP14-08

■ Material : stainless steel SUS304
 ■ Adapter : 110, 145, 190, 130

[Swage type]

(For 1000, 1100, 1400)

SC

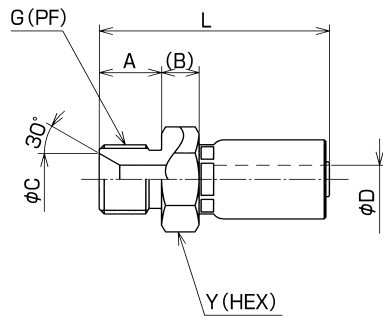

Part No.	Size No.	R	A	B	C	Min. I.D. ϕD	L	Y (HEX)	Weight (g)	Pusher	Die
SC-PF-04-14	04	1/4	14	8.5	9.5	3.5	51	19	43	PSA-04	SP14-04
SC-PF-06-14	06	3/8	15	9.0	12.5	6.8	54	22	72	PSA-06	SP14-06
SC-PF-08-14	08	1/2	18	10.0	18.0	9.5	61	27	115	PSA-08	SP14-08* SP10-08*

■ Material : steel
 ■ Adapter : O60
 * Use SP-14-08 for 1000-08 and SP-10-08 for 1100-08.

SL

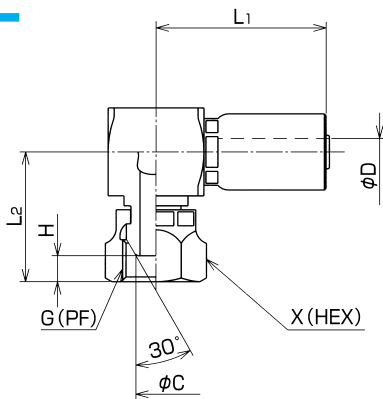

Part No.	Size No.	G	C	Min. I.D. ϕD	H	L1	L2	X (HEX)	Weight (g)	Pusher	Die
SL-PF-04-14	04	1/4	7.5	3.5	5.5	39	28	19	120	PSL-04	SP14-04
SL-PF-06-14	06	3/8	10.0	6.8	6.5	42	33	22	160	PSL-06	SP14-06
SL-PF-08-14	08	1/2	13.2	9.5	9.0	47	37	27	250	PSL-08	SP14-08* SP10-08*

■ Material : steel
 ■ Adapter : 110, 145, 190, 130
 * Use SP-14-08 for 1000-08 and SP-10-08 for 1100-08.

Hydraulic Hose	Airless-painting Hose	Clean Hose	Adapter	Hose Guard Parts, Specially-Treated Parts	Assembling Machine, Jig, Tool	Hose Assembling Method	Technical Document	Reference Document
----------------	-----------------------	------------	---------	---	-------------------------------	------------------------	--------------------	--------------------

Hose products

[Swage type]

(For 1000, 1100, 1400)

AE45

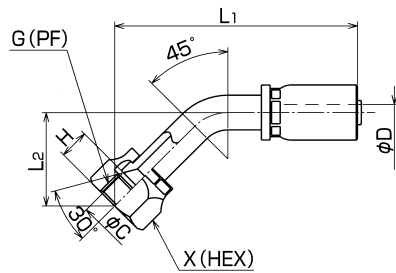

Part No.	Size No.	G	C	Min. I.D. ϕD	H	L ₁	L ₂	Y (HEX)	Weight (g)	Pusher	Die
AE45-G-04-14	04	1/4	9.0	3.2	8.0	61	18	19	57	PFB-01+PA-04	SP14-04
AE45-G-06-14	06	3/8	12.0	5.6	9.5	74	25	22	90	PFB-01+PA-06	SP14-06
AE45-G-08-14	08	1/2	15.5	8.7	12.0	87	29	27	143	PFB-01+PA-08	SP14-08* SP10-08*

■ Material : steel
 ■ Adapter : 010, 045, 090, 150, 020, 025, 064, 069, 030
 * Use SP-14-08 for 1000-08 and SP-10-08 for 1100-08.

AE90

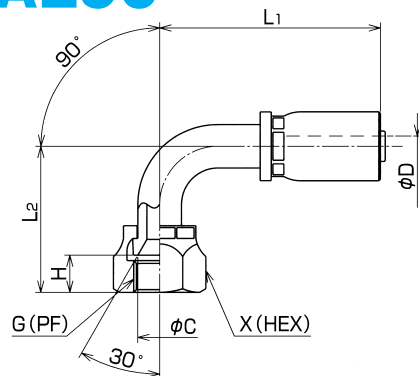

Part No.	Size No.	G	C	Min. I.D. ϕD	H	L ₁	L ₂	Y (HEX)	Weight (g)	Pusher	Die
AE90-G-04-14	04	1/4	9.0	3.2	8.0	51	33	19	59	PFB-01+PA-04	SP14-04
AE90-G-06-14	06	3/8	12.0	5.6	9.5	61	45	22	98	PFB-01+PA-06	SP14-06
AE90-G-08-14	08	1/2	15.5	8.7	12.0	68	52	27	153	PFB-01+PA-08	SP14-08* SP10-08*

■ Material : steel
 ■ Adapter : 010, 045, 090, 150, 020, 025, 064, 069, 030
 * Use SP-14-08 for 1000-08 and SP-10-08 for 1100-08.

AF45

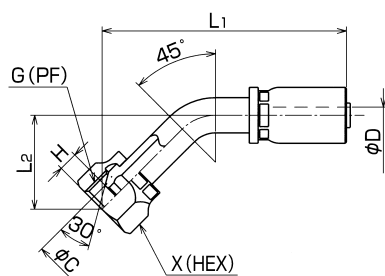

Part No.	Size No.	G	C	Min. I.D. ϕD	H	L ₁	L ₂	Y (HEX)	Weight (g)	Pusher	Die
AF45-G-04-14	04	1/4	7.0	3.2	5.5	63	19	19	58	PFB-01+PA-04	SP14-04
AF45-G-06-14	06	3/8	10.0	5.6	6.5	72	23	22	90	PFB-01+PA-06	SP14-06
AF45-G-08-14	08	1/2	14.0	8.7	9.0	88	30	27	147	PFB-01+PA-08	SP14-08* SP10-08*

■ Material : steel
 ■ Adapter : 110, 145, 190, 130
 * Use SP-14-08 for 1000-08 and SP-10-08 for 1100-08.

AF90

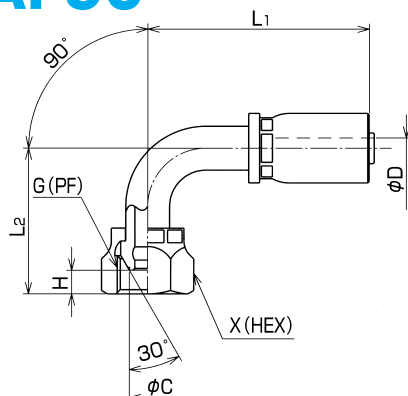

Part No.	Size No.	G	C	Min. I.D. ϕD	H	L ₁	L ₂	Y (HEX)	Weight (g)	Pusher	Die
AF90-G-04-14	04	1/4	7.0	3.2	5.5	51	33	19	61	PFB-01+PA-04	SP14-04
AF90-G-06-14	06	3/8	10.0	5.6	6.5	61	45	22	100	PFB-01+PA-06	SP14-06
AF90-G-08-14	08	1/2	14.0	8.7	9.0	68	52	27	156	PFB-01+PA-08	SP14-08* SP10-08*

■ Material : steel
 ■ Adapter : 110, 145, 190, 130
 * Use SP-14-08 for 1000-08 and SP-10-08 for 1100-08.

[Swage type]

(For 1000, 1100, 1400)

SK

MADE TO ORDER

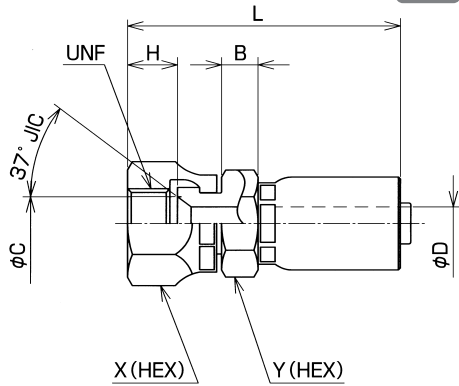

Part No.	Size No.	UNF	B	C	Min. I.D. φD	H	L	X (HEX)	Y (HEX)	Weight (g)	Pusher	Die
★ SK-7/16-04-14	04	7/16-20	6.5	7.5	3.5	9.0	51	19	17	58	PSK-04H	SP14-04
★ SK-9/16-06-14	06	9/16-18	7.5	11.0	6.8	10.0	57	22	19	82	PSK-06H	SP14-06
★ SK-3/4-08-14	08	3/4-16	4.5	14.5	9.5	11.5	57	27	22	105	PSE-14-08	SP14-08* SP10-08*

■ Material : steel
 * Use SP-14-08 for 1000-08 and SP-10-08 for 1100-08.
 ★Made-to-order

AK45

MADE TO ORDER

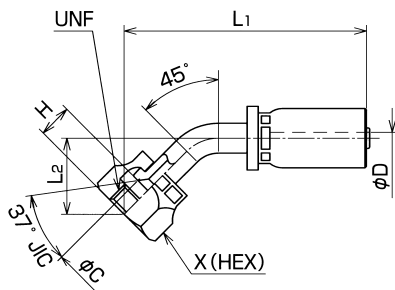

Part No.	Size No.	UNF	C	Min. I.D. φD	H	L ₁	L ₂	X (HEX)	Weight (g)	Pusher	Die
★ AK45-7/16-04-14C	04	7/16-20	7.5	3.2	9.0	70	27	19	57	PFB-01+PA-04	SP14-04
★ AK45-9/16-06-14C	06	9/16-18	11.0	5.6	10.0	91	39	22	90	PFB-01+PA-06	SP14-06
★ AK45-3/4-08-14C	08	3/4-16	14.5	8.7	12.0	98	40	27	143	PFB-01+PA-08	SP14-08* SP10-08*

■ Material : steel
 * Use SP-14-08 for 1000-08 and SP-10-08 for 1100-08.
 ★Made-to-order

AK90

MADE TO ORDER

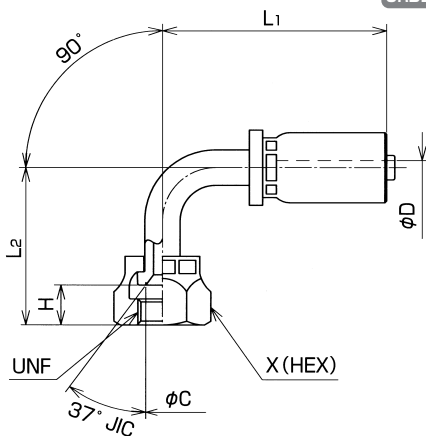

Part No.	Size No.	UNF	C	Min. I.D. φD	H	L ₁	L ₂	X (HEX)	Weight (g)	Pusher	Die
★ AK90-7/16-04-14C	04	7/16-20	7.5	3.2	9.0	51	36	19	59	PFB-01+PA-04	SP14-04
★ AK90-9/16-06-14C	06	9/16-18	11.0	5.6	10.0	61	40	22	98	PFB-01+PA-06	SP14-06
★ AK90-3/4-08-14C	08	3/4-16	14.5	8.7	12.0	68	57	27	153	PFB-01+PA-08	SP14-08* SP10-08*

■ Material : steel
 * Use SP-14-08 for 1000-08 and SP-10-08 for 1100-08.
 ★Made-to-order

Hydraulic Hose	Hydraulic hose products
Airless-painting Hose	Hydraulic hose products
Clean Hose	Hydraulic hose products
Adapter	Adapter
Hose Guard Parts, Specially-Treated Parts	Hose Guard Parts, Specially-Treated Parts
Assembling Machine, Jig, Tool	Assembling Machine, Jig, Tool
Hose Assembling Method	Hose Assembling Method
Technical Document	Technical Document
Reference Document	Reference Document

Hose products

1000 (light gray) Series

1000 (light gray)

Features

- Slim and lightweight
- Campucka coupling can be used

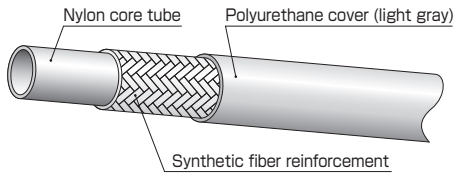

Part No.	Size			Max. working pressure		Min. burst pressure		Min. bending radius (mm)	Weight (g/m)	Coupling	
	Size No.	I.D. (in.)	I.D. (mm)	O.D. (mm)	(MPa)	(PSI)	(MPa)				(PSI)
1000-04-LGY	04	1/4	6.3	10.4	10.5	1,500	42.0	6,000	30	64	Campucka Swage
1000-06-LGY	06	3/8	9.5	14.0	10.5	1,500	42.0	6,000	60	90	
1000-08-LGY	08	1/2	12.7	17.4	10.5	1,500	42.0	6,000	80	131	

CAUTION : If you use Campucka, the maximum working pressure for Campucka must be applied.

- Appropriate fluid : mineral general operating oil
- Working temperature range : -40 to +100°C
- 🔧 If you use Campucka, the working temperature range for Campucka must be applied.
- Length in a unit package : 100m
- 🔧 Suitable hose coupling is the same as that for the 1000 series.
- 🔧 Color code "LGY" stands for light gray.

[Campucka type] Hydraulic push-one coupling (For 1000 (light gray))

CE

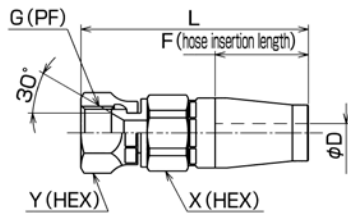

Part No.	G	Min. I.D. ϕD	F	L	X	Y	Weight (g)
CE-G-04-14L	1/4	3.5	26.0	64	19	19	85
CE-G-06-14L	3/8	6.0	29.0	72	22	22	115
CE-G-08-14L	1/2	9.0	35.0	83	27	27	205

- ⚠ **CAUTION** : If you use Campucka, the maximum working pressure for Campucka must be applied.
- ⚠ **CAUTION** : Handle with care not to drop couplings as an inner nipple could be self locked by pushing-out action to inlet of coupling.
- Material : steel
- Maximum working pressure : 10.5MPa
- Working temperature range : -20 to +100°C
- Adapter : 010, 045, 090, 150, 020, 025, 064, 069, 030

Features of Campucka and assembly mechanism

Assembling method ▶▶▶ p.57

1 Push-one connection

- Reduction of operation time (half that of our conventional product)
- Specialized swaging tool is not necessary. (Easy handling)
- Best for on-site length adjustment.
- Convenient for emergency repair.

4 Nipple stop mechanism

- Ratchet mechanism of our original lock ring is employed.
- Steady performance even for movable piping.
- Pressure variation is accommodated.

2 Detachable hose

- Hose is detachable for length adjustment when piping.
- Detachable tool is available.
- ⚠ **CAUTION** : Cannot be detached after pressurization.

Campucka assembly mechanism

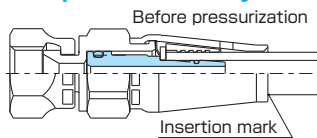

Swaging force proportional to inner pressure.

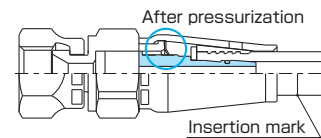

Detailed diagram



Lock ring prevents swage releasing after pressurization.

3 Correcting hose's twisted direction

- It is possible to correct the twisted direction of a hose.
- ⚠ **CAUTION** : Cannot be detached after pressurization.

[Swage type]

SE

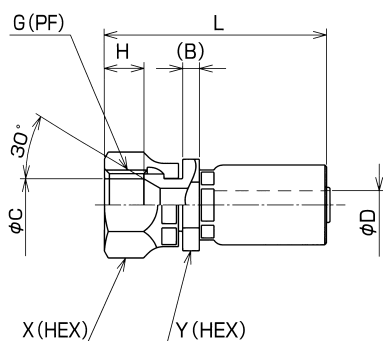

Part No.	Size No.	G	B	C	Min. I.D. ϕD	H	L	X (HEX)	Y (HEX)	Weight (g)	Pusher	Die
SE-PF-04-14	04	1/4	4.0	9.3	3.5	8.0	49	19	17	55	PSE14-04	SP14-04
SE-PF-06-14	06	3/8	4.0	12.3	6.8	9.5	53	22	19	75	PSE14-06	SP14-06
SE-PF-08-14	08	1/2	4.5	16.0	9.5	12.0	61	27	24	125	PSE14-08	SP14-08

- Material : steel
- Adapter : 010, 045, 090, 150, 020, 025, 064, 069, 030
- 🔗 Applicable hose couplings are the same as those for 1000 series.

F3130 (light gray) Series

F3130

Features

- Flexible and tough
- Campucka coupling (for F3130 series only) can be used

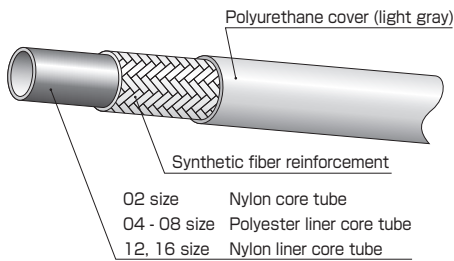

Part No.	Size			Max. working pressure		Min. burst pressure		Min. bending radius (mm)	Weight (g/m)	Coupling	
	Size No.	I.D. (in.)	I.D. (mm)	O.D. (mm)	(MPa)	(PSI)	(MPa)				(PSI)
F3130-02-LGY	02	1/8	3.6	8.3	20.0	2,900	72.0	10,500	15	45	Campucka Swage
F3130-04-LGY	04	1/4	6.3	12.5	19.5	2,850	77.0	11,200	40	105	
F3130-06-LGY	06	3/8	9.5	16.4	16.0	2,300	63.0	9,100	50	150	
F3130-08-LGY	08	1/2	12.7	20.3	14.0	2,000	56.0	8,000	75	210	
F3130-12-LGY	12	3/4	19.0	26.6	9.0	1,300	35.0	5,100	130	290	Swage
F3130-16-LGY	16	1	25.4	33.4	7.0	1,000	28.0	4,000	165	400	

CAUTION : If you use Campucka, the maximum working pressure for Campucka must be applied.

- Appropriate fluid : mineral general operating oil
- Working temperature range : -40 to +100°C
- 🔗 If you use Campucka, the working temperature range for Campucka must be applied.
- Length in a unit package : 100m for sizes 02, 04, 06, 08, and 50m for sizes 12, 16
- 🔗 Suitable hose coupling is the same as that for the N3130 and 3130 series.
- 🔗 Color code (-LGY) is appended to part Nos. "LGY" stands for light gray.

[Campucka type] Hydraulic push-one coupling (For F3130 (light gray))

CE (For F3130 series only)

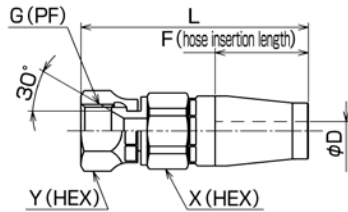

Part No.	Size No.	G	Min. I.D. φD	F	L	X	Y	Weight (g)
CE-G-02L	02	1/8	1.5	22.5	62	14	14	44
CE-G-04-F31-10L	04	1/4	3.5	28	74	19	19	105
CE-G-06-F31-10L	06	3/8	6.3	34	84	22	22	150
CE-G-08-F31-10L	08	1/2	9.4	37	92	27	27	225

CAUTION : Handle with care not to drop couplings as an inner nipple could be self locked by pushing-out action to inlet of coupling.

- Material : steel
- Maximum working pressure : 10.5MPa (CE-G-02L : 20.0MPa)
- Working temperature range : -20 to +100°C
- Adapter : 010, 045, 090, 150, 020, 025, 064, 069, 030

Features of Campucka and assembly mechanism

Assembling method ▶▶▶ p.57

1 Push-one connection

- Reduction of operation time (half that of our conventional product)
- Specialized swaging tool is not necessary. (Easy handling)
- Best for on-site length adjustment.
- Convenient for emergency repair.

2 Detachable hose

- Hose is detachable for length adjustment when piping.
 - Detachable tool is available.
- CAUTION** : Cannot be detached after pressurization.

3 Correcting hose's twisted direction

- It is possible to correct the twisted direction of a hose.
- CAUTION** : Cannot be detached after pressurization.

4 Nipple stop mechanism

- Ratchet mechanism of our original lock ring is employed.
- Steady performance even for movable piping.
- Pressure variation is accommodated.

Campucka assembly mechanism

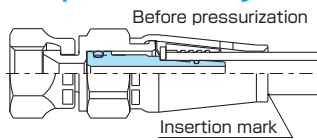

Swaging force proportional to inner pressure.

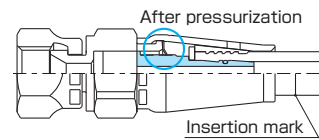

Detailed diagram



Lock ring prevents swage releasing after pressurization.

[Swage type]

SE

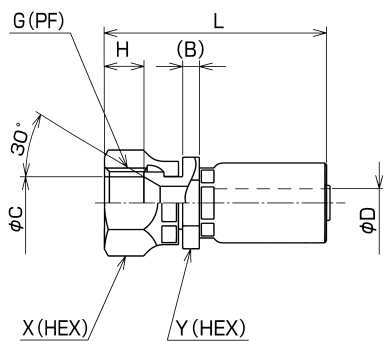

品番	Size No.	G	B	C	Min. I.D. φD	H	L	X (HEX)	Y (HEX)	Weight (g)	Pusher	Die
SSE-PF-02	02	1/8	4.0	6.8	1.8	7.0	42	14	14	25	PSE-02-001	SP3-02-001
SE-PF-04	04	1/4	8.0	9.3	3.9	8.0	64	19	17	75	PSE-04	SP3-04
SE-PF-06	06	3/8	9.5	12.3	6.8	9.5	71	22	19	100	PSE-06	SP3-06
SE-PF-08	08	1/2	9.0	15.5	10.0	12.5	80	27	27	170	PSE-08	SP3-08
SE-PF-12	12	3/4	10.5	21.5	16.0	13.0	87	36	36	280	PSE-12	SP3-12
SE-PF-16	16	1	11.0	27.5	20.9	15.0	105	41	41	400	PSE-16	SP3-16

- Material : steel
- Adapter : 010, 045, 090, 150, 020, 025, 064, 069, 030

Hydraulic Hose

Airless-painting Hose

Clean Hose

Adapter

Hose Guard Parts, Specially-Treated Parts

Assembling Machine, Jig, Tool

Hose Assembling Method

Technical Document

Reference Document

Hose products

N3130-3130-3000 Series

N3130

Features

- Flexible and tough
- JIS K 6375 A certificated, SAE100R7 certificated

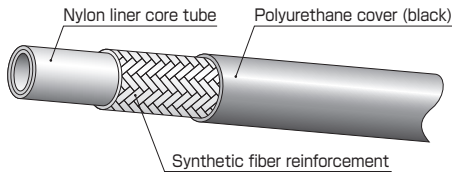

Part No.	Size			Max. working pressure		Min. burst pressure		Min. bending radius (mm)	Weight (g/m)	Coupling	
	Size No.	I.D. (in.)	I.D. (mm)	O.D. (mm)	(MPa)	(PSI)	(MPa)				(PSI)
N3130-03	03	3/16	4.8	10.4	21.0	3,000	84.0	12,000	20	65	Swage
N3130-04	04	1/4	6.4	12.7	19.5	2,850	77.0	11,200	40	105	
N3130-05	05	5/16	8.1	14.7	17.5	2,550	70.0	10,200	45	130	
N3130-06	06	3/8	9.8	16.4	16.0	2,300	63.0	9,100	50	150	
N3130-08	08	1/2	12.8	20.3	14.0	2,000	56.0	8,000	75	210	
N3130-12	12	3/4	19.2	26.6	9.0	1,300	35.0	5,100	130	290	
N3130-16	16	1	25.7	33.4	7.0	1,000	28.0	4,000	165	400	

- Appropriate fluid : mineral general operating oil
- Working temperature range : -40 to +100°C
- Length in a unit package : 100m for sizes 03, 04, 05, 06, 08, and 50m for sizes 12, 16

3130

Features

- Excellent oil and chemical durability
- Reusable coupling can be used

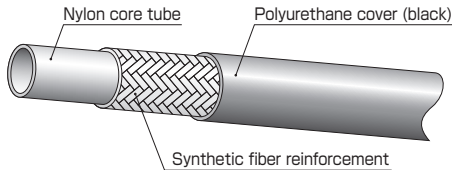

Part No.	Size			Max. working pressure		Min. burst pressure		Min. bending radius (mm)	Weight (g/m)	Coupling	
	Size No.	I.D. (in.)	I.D. (mm)	O.D. (mm)	(MPa)	(PSI)	(MPa)				(PSI)
3130-02	02	1/8	3.6	8.3	20.0	2,900	72.0	10,500	15	45	Swage Reusable <small>(Camoucka can be used only for size 02.)</small>
3130-03	03	3/16	4.8	10.4	20.0	2,900	72.0	10,500	30	65	
3130-04	04	1/4	6.3	12.4	20.0	2,900	72.0	10,500	40	105	
3130-05	05	5/16	7.9	13.8	18.0	2,600	65.0	9,400	50	115	
3130-06	06	3/8	9.5	16.1	18.0	2,600	65.0	9,400	60	150	
3130-08	08	1/2	12.7	19.9	16.0	2,300	58.0	8,400	80	210	
3130-12	12	3/4	19.0	26.2	10.0	1,450	36.0	5,200	160	290	

- Appropriate fluid : mineral general operating oil
- Working temperature range : -40 to +100°C
- Length in a unit package : 100m for sizes 02, 03, 04, 05, 06, 08, and 50m for size 12

3000

Features

- Excellent oil and chemical durability
- Reusable coupling can be used

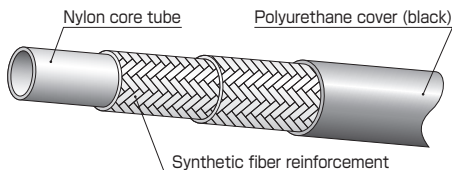

Part No.	Size			Max. working pressure		Min. burst pressure		Min. bending radius (mm)	Weight (g/m)	Coupling	
	Size No.	I.D. (in.)	I.D. (mm)	O.D. (mm)	(MPa)	(PSI)	(MPa)				(PSI)
3000-03	03	3/16	4.8	10.4	34.0	4,900	100.0	14,500	70	76	Swage Reusable
3000-04	04	1/4	6.3	12.5	30.0	4,350	90.0	13,000	75	98	
3000-06	06	3/8	9.5	16.0	24.0	3,500	70.0	10,000	120	140	
3000-08	08	1/2	12.7	19.8	20.0	2,900	60.0	8,700	160	199	
3000-12	12	3/4	19.0	26.2	13.0	1,900	38.0	5,500	250	276	
3000-16	16	1	25.4	33.0	10.0	1,450	30.0	4,350	300	366	

- Appropriate fluid : mineral general operating oil
- Working temperature range : -40 to +100°C
- Length in a unit package : 100m for sizes 03, 04, 06, 08, and 50m for sizes 12, 16

3700 Series (for low temperature environment)

3700

Features

- High flexibility and steady performance under low temperature environment (-55°C)
- JIS K 6375 A certificated, SAE100R7 certificated

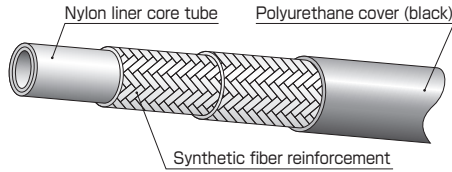

Part No.	Size			Max. working pressure		Min. burst pressure		Min. bending radius (mm)	Weight (g/m)	Coupling
	Size No.	I.D. (in.)	I.D. (mm)	O.D. (mm)	(MPa)	(PSi)	(MPa)			
3700-03	03	3/16	4.8	10.5	21.0	3,000	84.0	12,000	19	76
3700-04	04	1/4	6.3	12.8	19.5	2,850	77.0	11,200	32	101
3700-06	06	3/8	9.5	16.3	16.0	2,300	63.0	9,100	51	141
3700-08	08	1/2	12.7	20.2	14.0	2,000	56.0	8,000	76	196

- Appropriate fluid : mineral general operating oil
- Working temperature range : -55 to $+100^{\circ}\text{C}$
- Length in a unit package : 100m

Hydraulic Hose	Airless-painting Hose	Clean Hose	Adapter	Hose Guard Parts, Specially-Treated Parts	Assembling Machine, Jig, Tool	Hose Assembling Method	Technical Document	Reference Document
----------------	-----------------------	------------	---------	---	-------------------------------	------------------------	--------------------	--------------------

Hose products

[Swage type]

(For N3130, 3130, 3000) (For 3700)

SA

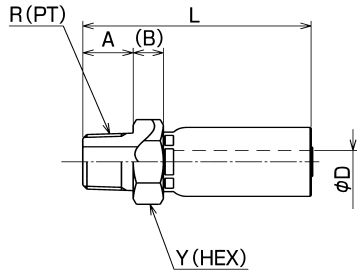

Part No.	Size No.	R	A	B	Min. I.D. φD	L	Y (HEX)	Weight (g)	Pusher	Die
SSA-PT-02	02	1/8	10	6.5	1.8	38	14	15	PSA-02	SP3-02-001
SA-PT-03	03	1/4	13	8.5	2.8	57	19	50	PSA-04	SP3-03
SA-PT-04	04	1/4	13	8.5	3.9	61	19	60	PSA-04	SP3-04
SA-PT-05	05	3/8	15	9.0	5.6	62	22	80	PSA-06	SP3-05
SA-PT-06	06	3/8	15	9.0	6.8	67	22	90	PSA-06	SP3-06
SA-PT-08	08	1/2	18	10.0	10.0	76	27	140	PSA-08	SP3-08
SA-PT-12	12	3/4	20	10.0	16.0	82	36	220	PSA-12	SP3-12
SA-PT-16	16	1	23	10.0	20.9	100	41	340	PSA-16	SP3-16

- Material : steel
- Adapter : 030, 130

Stainless steel type

Part No.	Size No.	R	A	B	Min. I.D. φD	L	Y (HEX)	Weight (g)	Pusher	Die	
										First	Second
SSA-PT-02-S	02	1/8	10	6.5	1.8	38	14	15	PSA-02	SP3-02-001	-
SA-PT-03-S	03	1/4	13	8.5	3.0	57	19	50	PSA-04	SP3-03-1-ST	SP3-03
SA-PT-04-S	04	1/4	13	8.5	3.9	60	19	60	PSA-04	SP3-04-1-ST	KM-04* SP3-04*
SA-PT-06-S	06	3/8	15	9.0	6.8	67	22	90	PSA-06	SP3-06-1-ST	SP3-06
SA-PT-08-S	08	1/2	18	10.0	10.0	76	27	140	PSA-08	SP3-08-1-ST	SP3-08
SA-PT-12-S	12	3/4	20	10.0	16.0	82	36	220	PSA-12	SP3-12-1-ST	SP3-12
SA-PT-16-S	16	1	23	10.0	20.9	100	41	340	PSA-16	SP3-16-1-ST	SP3-16

- Material : stainless steel SUS304
- Adapter : 030, 130
- * Use KM-04 for N3130 and 3700, and SP3-04 for 3130 and 3000.

SO

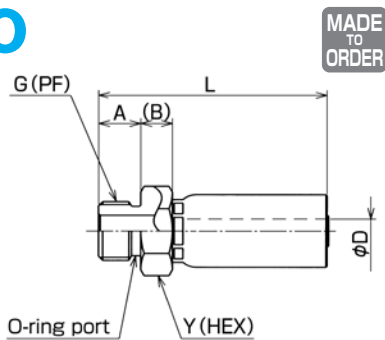

Part No.	Size No.	G	A	B	Min. I.D. φD	L	Y (HEX)	Weight (g)	Pusher	Die
SO-PF-04	04	1/4	11	8.5	3.9	59	19	55	PSA-04	SP3-04
SO-PF-06	06	3/8	12	9.0	6.8	64	22	85	PSA-06	SP3-06
★ SO-PF-08	08	1/2	15	10.0	10.0	73	27	135	PSA-08	SP3-08

- Material : steel
- O-ring : 04-JIS B2401-P11, 06-JIS B2401-P14, 08-JIS B2401-P18
- O-ring is not mounted inside.
- ★Made-to-order

SC

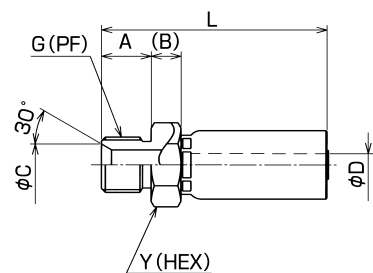

Part No.	Size No.	G	A	B	C	Min. I.D. φD	L	Y (HEX)	Weight (g)	Pusher	Die
SC-PF-03	03	1/4	13	8.5	9.5	2.8	57	19	50	PSA-04	SP3-03
SC-PF-04	04	1/4	13	8.5	9.5	3.9	61	19	60	PSA-04	SP3-04
SC-PF-06	06	3/8	15	9.0	12.5	6.8	67	22	90	PSA-06	SP3-06
SC-PF-08	08	1/2	18	10.0	16.5	10.0	76	27	140	PSA-08	SP3-08
SC-PF-12	12	3/4	20	10.0	21.5	16.0	82	36	220	PSA-12	SP3-12
SC-PF-16	16	1	22	10.0	27.5	20.9	99	41	340	PSA-16	SP3-16

- Material : steel
- Adapter : 060

[Swage type]

(For N3130, 3130, 3000) (For 3700)

SE

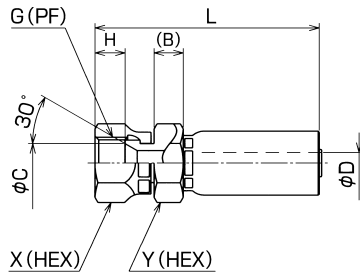

Part No.	Size No.	G	B	C	Min. I.D. φD	H	L	X (HEX)	Y (HEX)	Weight (g)	Pusher	Die
SSE-PF-02	02	1/8	4.0	6.8	1.8	7.0	42	14	14	25	PSE-02-001	SP3-02-001
SE-PF-03	03	1/4	6.0	9.5	2.8	8.0	58	19	19	70	PSE-03	SP3-03
SE-PF-04	04	1/4	8.0	9.3	3.9	8.0	64	19	17	75	PSE-04	SP3-04
SE-PF-05	05	3/8	8.5	12.0	5.6	10.0	66	22	22	100	PSE-05	SP3-05
SE-PF-06	06	3/8	9.5	12.3	6.8	10.0	71	22	19	100	PSE-06	SP3-06
SE-PF-08	08	1/2	9.0	15.5	10.0	12.5	80	27	27	170	PSE-08	SP3-08
SE-PF-12	12	3/4	10.5	21.5	16.0	13.0	87	36	36	280	PSE-12	SP3-12
SE-PF-16	16	1	11.0	27.5	20.9	15.0	105	41	41	400	PSE-16	SP3-16

■ Material : steel
 ■ Adapter : 010, 045, 090, 150, 020, 025, 064, 069, 030

Stainless steel type

Part No.	Size No.	G	B	C	Min. I.D. φD	H	L	X (HEX)	Y (HEX)	Weight (g)	Pusher	Die	
												First	Second
SSE-PF-02-S	02	1/8	4.0	7.0	1.8	7.0	42	14	14	25	PSE-02-001	SP3-2-001	-
SE-PF-03-S	03	1/4	6.0	9.0	3.0	8.0	58	19	19	70	PSE-03	SP3-03-1-ST	SP3-03
SE-PF-04-S	04	1/4	8.5	9.5	3.9	8.0	63	19	19	80	PSE-04	SP3-04-1-ST	KM-04* SP3-04*
SE-PF-06-S	06	3/8	9.5	12.5	6.8	10.0	71	22	22	110	PSE-06	SP3-06-1-ST	SP3-06
SE-PF-08-S	08	1/2	9.0	16.0	10.0	12.0	80	27	27	170	PSE-08	SP3-08-1-ST	SP3-08
SE-PF-12-S	12	3/4	10.5	21.5	16.0	13.0	87	36	36	280	PSE-12	SP3-12-1-ST	SP3-12
SE-PF-16-S	16	1	11.0	27.5	20.9	15.0	105	41	41	400	PSE-16	SP3-16-1-ST	SP3-16

■ Material : stainless steel SUS304
 ■ Adapter : 010, 045, 090, 150, 020, 025, 064, 069, 030
 * Use KM-04 for N3130 and 3700, and SP3-04 for 3130 and 3000.

SF

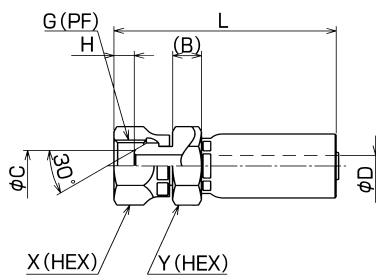

Part No.	Size No.	G	B	C	Min. I.D. φD	H	L	X (HEX)	Y (HEX)	Weight (g)	Pusher	Die
SSF-PF-02	02	1/8	4.0	5.0	1.8	3.0	41	14	14	25	PSE-02-001	SP3-02-001
SF-PF-03	03	1/4	6.0	7.5	2.8	5.5	58	19	19	70	PSE-03	SP3-03
SF-PF-04	04	1/4	8.5	7.5	3.9	5.5	63	19	17	75	PSE-04	SP3-04
SF-PF-05	05	3/8	8.5	10.0	5.6	6.5	66	22	22	100	PSE-05	SP3-05
SF-PF-06	06	3/8	9.5	10.0	6.8	6.5	71	22	19	100	PSE-06	SP3-06
SF-PF-08	08	1/2	9.0	14.0	10.0	9.0	80	27	27	170	PSE-08	SP3-08
SF-PF-12	12	3/4	10.5	19.0	16.0	9.5	87	36	36	280	PSE-12	SP3-12
SF-PF-16	16	1	11.0	25.4	20.9	10.0	105	41	41	410	PSE-16	SP3-16

■ Material : steel
 ■ Adapter : 110, 145, 190, 130

Stainless steel type

Part No.	Size No.	G	B	C	Min. I.D. φD	H	L	X (HEX)	Y (HEX)	Weight (g)	Pusher	Die	
												First	Second
SSF-PF-02-S	02	1/8	4.0	5.0	1.8	3.0	41	14	14	25	PSE-02-001	SP3-2-001	-
SF-PF-04-S	04	1/4	8.5	7.5	3.9	5.5	63	19	19	80	PSE-04	SP3-04-1-ST	KM-04* SP3-04*
SF-PF-06-S	06	3/8	9.5	10.0	6.8	6.5	71	22	22	110	PSE-06	SP3-06-1-ST	SP3-06
SF-PF-08-S	08	1/2	9.0	13.2	10.0	9.0	80	27	27	170	PSE-08	SP3-08-1-ST	SP3-08
SF-PF-12-S	12	3/4	10.5	19.0	16.0	9.5	87	36	36	280	PSE-12	SP3-12-1-ST	SP3-12
SF-PF-16-S	16	1	11.0	25.4	20.9	10.0	105	41	41	400	PSE-16	SP3-16-1-ST	SP3-16

■ Material : stainless steel SUS304
 ■ Adapter : 110, 145, 190, 130
 * Use KM-04 for N3130 and 3700, and SP3-04 for 3130 and 3000.

Hydraulic Hose products

- Hydraulic Hose
- Airless-painting Hose
- Clean Hose
- Adapter
- Hose Guard Parts, Specially-Treated Parts
- Assembling Machine, Jig, Tool
- Hose Assembling Method
- Technical Document
- Reference Document

Hose products

[Swage type]

(For N3130, 3130, 3000) (For 3700)

SLE

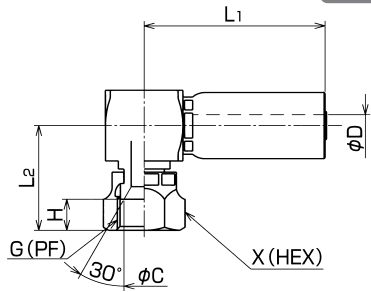

MADE TO ORDER

Part No.	Size No.	G	C	Min. I.D. ϕD	H	L ₁	L ₂	X (HEX)	Weight (g)	Pusher	Die
★ SLE-PF-04	04	1/4	9.5	3.9	8.0	49	28	19	115	PSL-04	SP3-04
★ SLE-PF-06	06	3/8	12.5	6.8	9.5	55	33	22	116	PSL-06	SP3-06
★ SLE-PF-08	08	1/2	16.0	10.0	12.0	62	37	27	255	PSL-08	SP3-08

- Material : steel
- Adapter : 010, 045, 090, 150, 020, 025, 064, 069, 030
- ★Made-to-order

SL

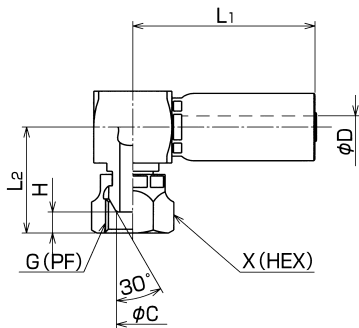

Part No.	Size No.	G	C	Min. I.D. ϕD	H	L ₁	L ₂	X (HEX)	Weight (g)	Pusher	Die
SL-PF-04	04	1/4	7.5	3.9	5.5	54	28	19	115	PSL-04	SP3-04
SL-PF-06	06	3/8	10.0	6.8	6.5	55	33	22	165	PSL-06	SP3-06
SL-PF-08	08	1/2	13.2	10.0	9.0	62	37	27	255	PSL-08	SP3-08
★ SL-PF-12	12	3/4	19.0	16.0	9.5	71	43	36	550	PSL-12	SP3-12

- Material : steel
- Adapter : 110, 145, 190, 130
- ★Made-to-order

AE45, SE45

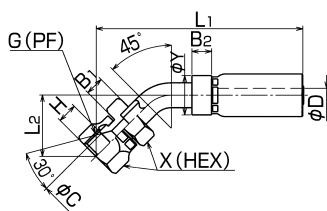
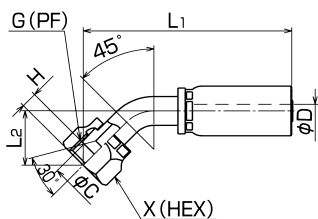

Part No.	Size No.	G	C	Min. I.D. ϕD	H	L ₁	L ₂	X (HEX)	Weight (g)	Pusher	Die
AE45-G-04	04	1/4	9.0	3.2	8.0	71	18	19	70	PFB-01+PA-04	SP3-04
AE45-G-06	06	3/8	12.0	5.6	9.5	87	25	22	105	PFB-01+PA-06	SP3-06
AE45-G-08	08	1/2	15.5	8.7	12.5	102	29	27	170	PFB-01+PA-08	SP3-08

- Material : steel
- Adapter : 010, 045, 090, 150, 020, 025, 064, 069, 030

Part No.	Size No.	G	B ₁	B ₂	C	Min. I.D. ϕD	H	L ₁	L ₂	X (HEX)	ϕY	Weight (g)	Pusher	Die
★ SE45-PF-12	12	3/4	10.5	12.5	21.0	16.0	13.5	129	40	36	30	380	PFB-02+PHB-12	SP3-12
★ SE45-PF-16	16	1	12.5	12.5	28.0	20.9	16.5	154	47	41	36	590	PFB-02+PHB-16	SP3-16

- Material : steel
- Adapter : 010, 045, 090, 150, 020, 025, 064, 069, 030
- ★Made-to-order

[Swage type]

(For N3130, 3130, 3000) (For 3700)

AE90, SE90

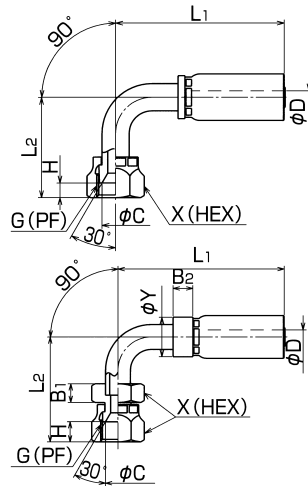

Part No.	Size No.	G	C	Min. I.D. phi D	H	L1	L2	X (HEX)	Weight (g)	Pusher	Die
AE90-G-04	04	1/4	9.0	3.2	8.0	59	33	19	75	PFB-01+PA-04	SP3-04
AE90-G-06	06	3/8	12.0	5.6	9.5	74	45	22	115	PFB-01+PA-06	SP3-06
AE90-G-08	08	1/2	15.5	8.7	12.5	83	54	27	180	PFB-01+PA-08	SP3-08

■ Material : steel
 ■ Adapter : 010, 045, 090, 150, 020, 025, 064, 069, 030

Part No.	Size No.	G	B1	B2	C	Min. I.D. phi D	H	L1	L2	X (HEX)	phi Y	Weight (g)	Pusher	Die
SE90-PF-12	12	3/4	10.5	12.5	21.0	16.0	13.5	108	77	36	30	405	PFB-02+PHB-12	SP3-12
SE90-PF-16	16	1	12.5	12.5	28.0	20.9	16.5	127	87	41	36	645	PFB-02+PHB-16	SP3-16

■ Material : steel
 ■ Adapter : 010, 045, 090, 150, 020, 025, 064, 069, 030

AF45, SF45

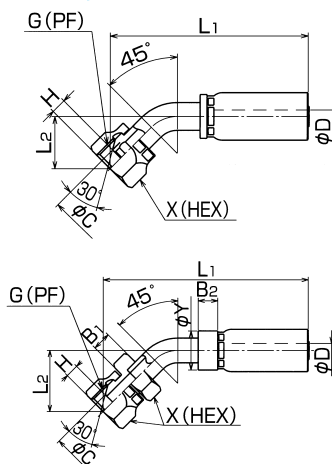

Part No.	Size No.	G	C	Min. I.D. phi D	H	L1	L2	X (HEX)	Weight (g)	Pusher	Die
AF45-G-04	04	1/4	7.0	3.2	5.5	73	19	19	70	PFB-01+PA-04	SP3-04
AF45-G-06	06	3/8	10.0	5.6	6.5	85	23	22	110	PFB-01+PA-06	SP3-06
AF45-G-08	08	1/2	14.0	8.7	9.0	103	29	27	155	PFB-01+PA-08	SP3-08

■ Material : steel
 ■ Adapter : 110, 145, 190, 130

Part No.	Size No.	G	B1	B2	C	Min. I.D. phi D	H	L1	L2	X (HEX)	phi Y	Weight (g)	Pusher	Die
★ SF45-PF-12	12	3/4	10.5	12.5	19.0	16.0	9.5	129	40	36	30	381	PFB-02+PHB-12	SP3-12
★ SF45-PF-16	16	1	11.0	12.5	25.4	20.9	10.0	151	60	41	36	601	PFB-02+PHB-16	SP3-16

■ Material : steel
 ■ Adapter : 110, 145, 190, 130
 ★Made-to-order

AF90, SF90

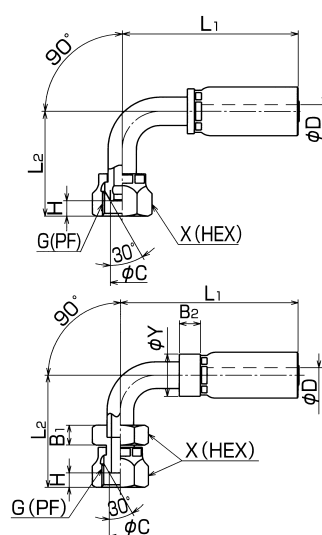

Part No.	Size No.	G	C	Min. I.D. phi D	H	L1	L2	X (HEX)	Weight (g)	Pusher	Die
AF90-G-04	04	1/4	7.0	3.2	5.5	61	33	19	75	PFB-01+PA-04	SP3-04
AF90-G-06	06	3/8	10.0	5.6	6.5	74	45	22	115	PFB-01+PA-06	SP3-06
AF90-G-08	08	1/2	14.0	8.7	9.0	83	52	27	165	PFB-01+PA-08	SP3-08

■ Material : steel
 ■ Adapter : 110, 145, 190, 130

Part No.	Size No.	G	B1	B2	C	Min. I.D. phi D	H	L1	L2	X (HEX)	phi Y	Weight (g)	Pusher	Die
★ SF90-PF-12	12	3/4	10.5	12.5	19.0	16.0	9.5	108	77	36	30	405	PFB-02+PHB-12	SP3-12
★ SF90-PF-16	16	1	11.0	12.5	25.4	20.9	10.0	127	86	41	36	645	PFB-02+PHB-16	SP3-16

■ Material : steel
 ■ Adapter : 110, 145, 190, 130
 ★Made-to-order

Hydraulic Hose products

- Hydraulic Hose
- Airless-painting Hose
- Clean Hose
- Adapter
- Hose Guard Parts, Specially-Treated Parts
- Assembling Machine, Jig, Tool
- Hose Assembling Method
- Technical Document
- Reference Document

Hose products

[Swage type]

(For N3130, 3130, 3000) (For 3700)

SK

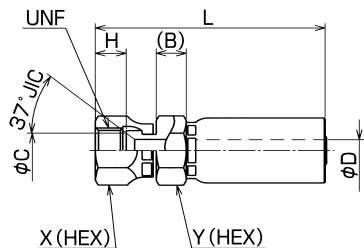

Part No.	Size No.	UNF	B	C	Min. I.D. φD	H	L	X (HEX)	Y (HEX)	Weight (g)	Pusher	Die
SK-7/16-03	03	7/16	6.5	7.5	2.8	10.0	58	15.9	14.3	50	PSK-7/16-04	SP3-03
SK-7/16-04	04	7/16	6.5	7.5	3.9	10.0	61	15.9	15.9	60	PSK-7/16-04	SP3-04
★ SK-1/2-04	04	1/2	9.5	9.0	3.9	9.5	65	19.0	15.9	60	PSK-9/16-04**	SP3-04
★ SK-9/16-04	04	9/16	7.0	11.0	3.9	10.0	65	19.0	15.9	65	PSK-9/16-04	SP3-04
SK-9/16-06	06	9/16	9.5	11.0	6.8	10.0	72	19.0	19.0	90	PSK-9/16-06	SP3-06
★ SK-3/4-06	06	3/4	8.5	14.5	6.8	12.0	72	24.0	19.0	95	PSK-3/4-06	SP3-06
SK-3/4-08	08	3/4	9.0	14.5	10.0	12.0	77	24.0	22.0	125	PSK-3/4-08	SP3-08
★ SK-7/8-08	08	7/8	9.0	17.3	10.0	13.0	81	27.0	22.0	145	PSE-08	SP3-08

■ Material : steel

★ Made-to-order

★★又は、PSK-1/2-04

AK45

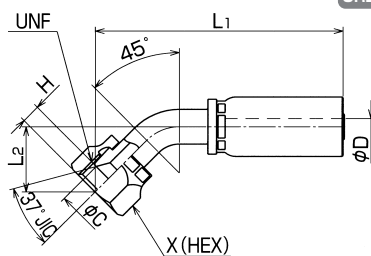

Part No.	Size No.	UNF	C	Min. I.D. φD	H	L ₁	L ₂	X (HEX)	Weight (g)	Pusher	Die
★ AK45-7/16-03	03	7/16	7.5	2.6	9.0	69	18	19	57	PFB-01+PA-04	SP3-03
★ AK45-7/16-04-C	04	7/16	7.5	3.2	9.0	72	18	19	64	PFB-01+PA-04	SP3-04
★ AK45-9/16-06-C	06	9/16	11.0	5.6	10.0	89	24	22	110	PFB-01+PA-06	SP3-06
★ AK45-3/4-08-C	08	3/4	14.5	8.7	11.5	100	27	27	161	PFB-01+PA-08	SP3-08

■ Material : steel

★ Made-to-order

AK90

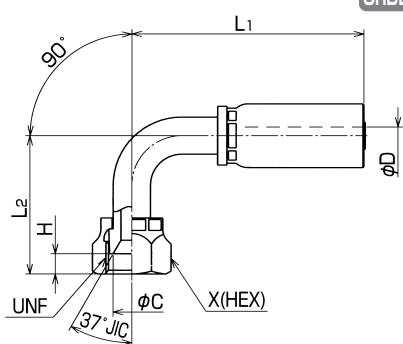

Part No.	Size No.	UNF	C	Min. I.D. φD	H	L ₁	L ₂	X (HEX)	Weight (g)	Pusher	Die
★ AK90-7/16-03	03	7/16	7.5	2.6	9.0	58	32	19	62	PFB-01+PA-04	SP3-03
★ AK90-7/16-04-C	04	7/16	7.5	3.2	9.0	61	32	19	69	PFB-01+PA-04	SP3-04
★ AK90-9/16-06-C	06	9/16	11.0	5.6	10.0	74	43	22	117	PFB-01+PA-06	SP3-06
★ AK90-3/4-08-C	08	3/4	14.5	8.7	11.5	83	47	27	171	PFB-01+PA-08	SP3-08

■ Material : steel

★ Made-to-order

[Campucka type] Hydraulic push-one coupling (For 3130-02 only)

CA

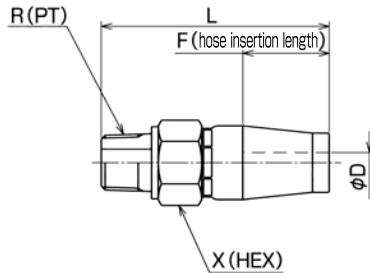

Part No.	Size No.	R	Min. I.D. ϕD	F	L	X	Weight (g)
CA-R-02L	02	1/8	1.5	22.5	56	14	36

CAUTION : Handle with care not to drop couplings as an inner nipple could be self locked by pushing-out action to inlet of coupling.

- Material : steel
- Working temperature range : 20.0MPa
- Working temperature range : -20 to +100°C
- Adapter : 030, 130

CE

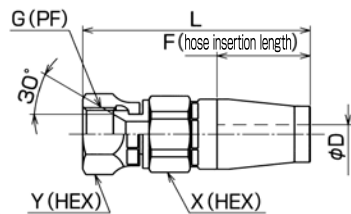

Part No.	Size No.	G	Min. I.D. ϕD	F	L	X	Y	Weight (g)
CE-G-02L	02	1/8	1.5	22.5	62	14	14	44

CAUTION : Handle with care not to drop couplings as an inner nipple could be self locked by pushing-out action to inlet of coupling.

- Material : steel
- Working temperature range : 20.0MPa
- Working temperature range : -20 to +100°C
- Adapter : 010, 045, 090, 150, 030

CF

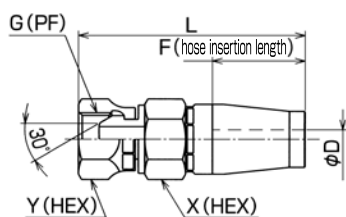

Part No.	Size No.	G	Min. I.D. ϕD	F	L	X	Y	Weight (g)
CF-G-02L	02	1/8	1.5	22.5	62	14	14	45

CAUTION : Handle with care not to drop couplings as an inner nipple could be self locked by pushing-out action to inlet of coupling.

- Material : steel
- Working temperature range : 20.0MPa
- Working temperature range : -20 to +100°C
- Adapter : 110, 145, 190, 130

Features of Campucka and assembly mechanism

Assembling method ▶▶▶ p.57

1 Push-one connection

- Reduction of operation time (half that of our conventional product)
- Specialized swaging tool is not necessary. (Easy handling)
- Best for on-site length adjustment.
- Convenient for emergency repair.

4 Nipple stop mechanism

- Ratchet mechanism of our original lock ring is employed.
- Steady performance even for movable piping.
- Pressure variation is accommodated.

2 Detachable hose

- Hose is detachable for length adjustment when piping.
 - Detachable tool is available.
- CAUTION** : Cannot be detached after pressurization.

Campucka assembly mechanism

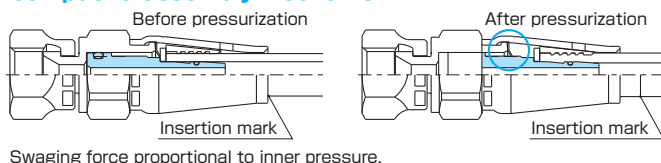

3 Correcting hose's twisted direction

- It is possible to correct the twisted direction of a hose.
- CAUTION** : Cannot be detached after pressurization.

Detailed diagram



Lock ring prevents swage releasing after pressurization.

CAUTION : Handle with care not to drop couplings as an inner nipple could be self locked by pushing-out action to inlet of coupling.

Hydraulic Hose	Hydraulic hose products
Airless-painting Hose	
Clean Hose	
Adapter	
Hose Guard Parts, Specially-Treated Parts	
Assembling Machine, Jig, Tool	
Hose Assembling Method	
Technical Document	
Reference Document	

Hose products

[Reusable type]

(For 3130, 3000)

A

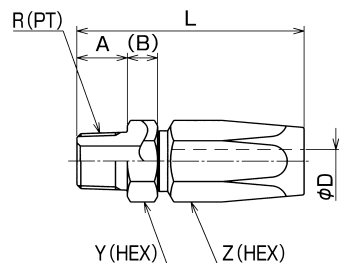

Part No.	Size No.	R	A	B	Min. I.D. φD	L	Y (HEX)	Z (HEX)	Weight (g)
A-PT-02	02	1/8	10	6.5	2.8	42	12	12	25
A-PT-03	03	1/4	14	7.0	3.4	51	17	14	45
A-PT-04	04	1/4	14	7.0	5.0	57	17	17	60
A-PT-05	05	3/8	15	9.0	6.0	65	21	19	100
A-PT-06	06	3/8	15	9.0	7.0	68	21	21	120
A-PT-08	08	1/2	18	10.0	9.6	79	26	26	210
A-PT-12	12	3/4	20	12.0	16.5	85	35	35	370
★ A-PT-16	16	1	23	13.0	21.5	92	41	41	500

- Material : steel
- Adapter : 030, 130
- ★ Made-to-order

Stainless steel type

Part No.	Size No.	R	A	B	Min. I.D. φD	L	Y (HEX)	Z (HEX)	Weight (g)
A-PT-02-S	02	1/8	10	6.5	2.8	42	12	12	25
A-PT-04-S	04	1/4	14	7.0	5.0	57	17	17	60
A-PT-06-S	06	3/8	15	9.0	7.0	68	21	21	120
★ A-PT-08-S	08	1/2	18	10.0	9.6	79	26	26	210
★ A-PT-12-S	12	3/4	20	12.0	16.5	85	35	35	370

- Material : stainless steel SUS304
- Adapter : 030, 130
- ★ Made-to-order

E

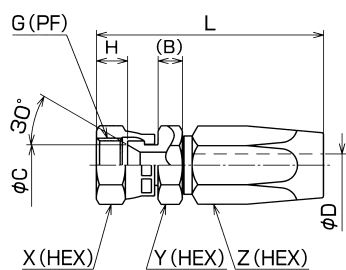

Part No.	Size No.	G	B	C	Min. I.D. φD	H	L	X (HEX)	Y (HEX)	Z (HEX)	Weight (g)
E-PF-02	02	1/8	6.5	7.0	2.8	7.0	48	14	12	12	35
E-PF-03	03	1/4	6.5	9.5	3.4	8.0	54	17	17	14	60
E-PF-04	04	1/4	6.5	9.5	5.0	8.5	59	17	17	17	70
E-PF-05	05	3/8	6.5	12.5	6.0	9.5	66	21	21	19	110
E-PF-06	06	3/8	7.5	12.5	7.0	9.5	70	21	21	21	130
E-PF-08	08	1/2	7.5	16.0	9.6	12.5	82	26	26	26	220
E-PF-12	12	3/4	9.5	21.5	16.5	13.0	86	35	35	35	400
E-PF-16	16	1	9.5	27.5	21.5	16.5	92	41	41	41	530

- Material : steel
- Adapter : 010, 045, 090, 150, 020, 025, 064, 069, 030

Stainless steel type

Part No.	Size No.	G	B	C	Min. I.D. φD	H	L	X (HEX)	Y (HEX)	Z (HEX)	Weight (g)
E-PF-02-S	02	1/8	6.5	7.0	2.8	7.0	48	14	12	12	35
E-PF-04-S	04	1/4	6.5	9.5	5.0	8.5	59	17	17	17	70
E-PF-06-S	06	3/8	7.5	12.5	7.0	9.5	70	21	21	21	130
★ E-PF-08-S	08	1/2	7.5	16.0	9.6	12.5	82	26	26	26	220
★ E-PF-12-S	12	3/4	9.5	21.5	16.5	13.0	86	35	35	35	400

- Material : stainless steel SUS304
- Adapter : 010, 045, 090, 150, 020, 025, 064, 069, 030
- ★ Made-to-order

[Reusable type]

(For 3130, 3000)

F

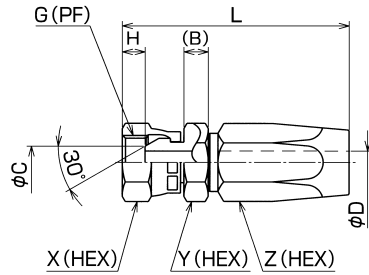

Part No.	Size No.	G	B	C	Min. I.D. ϕD	H	L	X (HEX)	Y (HEX)	Z (HEX)	Weight (g)
F-PF-02	02	1/8	6.5	5.0	2.8	3.0	48	14	12	12	35
F-PF-03	03	1/4	6.5	7.0	3.4	6.0	54	17	17	14	60
F-PF-04	04	1/4	6.5	7.0	5.0	6.0	59	17	17	17	70
F-PF-05	05	3/8	6.5	10.0	6.0	7.0	66	21	21	19	110
F-PF-06	06	3/8	7.5	10.0	7.0	7.0	70	21	21	21	130
F-PF-08	08	1/2	7.5	14.0	9.6	8.5	82	26	26	26	220
F-PF-12	12	3/4	9.5	19.0	16.5	9.0	86	35	35	35	410
★F-PF-16	16	1	9.5	25.0	21.5	10.5	92	41	41	41	570

- Material : steel
- Adapter : 110, 145, 190, 130
- ★Made-to-order

C

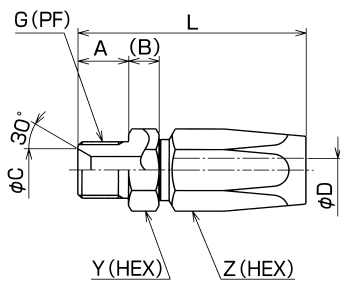

Part No.	Size No.	G	A	B	C	Min. I.D. ϕD	L	Y (HEX)	Z (HEX)	Weight (g)
C-PF-02	02	1/8	10	6.5	7.0	2.8	42	12	12	25
★C-PF-03	03	1/4	14	7.0	9.5	3.4	51	17	14	45
C-PF-04	04	1/4	14	7.0	9.5	5.0	57	17	17	60
C-PF-06	06	3/8	15	9.0	12.5	7.0	68	21	21	120
C-PF-08	08	1/2	18	10.0	16.5	9.6	79	26	26	210
★C-PF-12	12	3/4	20	12.0	22.0	16.5	85	35	35	500

- Material : steel
- Adapter : 060
- ★Made-to-order

Hydraulic Hose	Airless-painting Hose	Clean Hose	Adapter	Hose Guard Parts, Specially-Treated Parts	Assembling Machine, Jig, Tool	Hose Assembling Method	Technical Document	Reference Document
----------------	-----------------------	------------	---------	---	-------------------------------	------------------------	--------------------	--------------------

Hose products

N3000 Series

N3000

Features

- Flexible and tough
- 100R18 Certified (04, 06 and 08 size only)

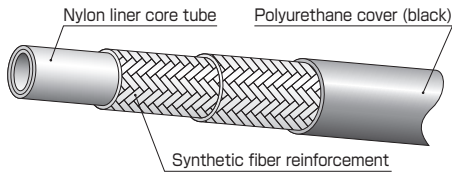

Part No.	Size			Max. working pressure		Min. burst pressure		Min. bending radius (mm)	Weight (g/m)	Coupling	
	Size No.	I.D. (in.)	O.D. (mm)	(MPa)	(PSI)	(MPa)	(PSI)				
N3000-04	04	1/4	6.3	13.3	28.0	4,050	112.0	16,200	50	120	Swage
N3000-06	06	3/8	9.5	17.5	21.0	3,000	84.0	12,000	65	190	
N3000-08	08	1/2	12.7	21.3	21.0	3,000	84.0	12,000	80	280	
N3000-10	10	5/8	15.9	25.5	17.5	2,550	70.0	10,200	120	355	

- Appropriate fluid : mineral general operating oil
- Working temperature range : -40 to +100°C
- Length in a unit package : 100m for sizes 04, 06, 08, and 50m for sizes 10

HT (High Temperature) Series

HT (High Temperature)

Features

- High temperature (120°C) oil can be used.

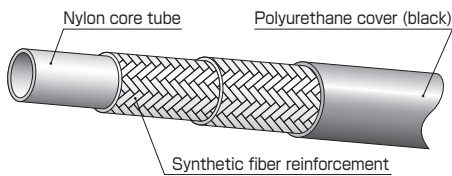

Part No.	Size			Max. working pressure		Min. burst pressure		Min. bending radius (mm)	Weight (g/m)	Coupling	
	Size No.	I.D. (in.)	O.D. (mm)	(MPa)	(PSI)	(MPa)	(PSI)				
HT-04	04	1/4	6.3	13.3	28.0	4,050	112.0	16,200	40	125	Swage
HT-06	06	3/8	9.5	17.5	21.0	3,000	84.0	12,000	60	180	
HT-08	08	1/2	12.7	21.3	21.0	3,000	84.0	12,000	80	255	
HT-10	10	5/8	15.9	25.5	17.5	2,550	70.0	10,200	120	355	

- Appropriate fluid : mineral general operating oil
- Working temperature range : -40 to +120°C
- Length in a unit package : 100m for sizes 04, 06, 08, and 50m for sizes 10

🔧 Stainless fittings are not available for HT series.

[Swage type]

Caution : The size O4 coupling for N3130 can also be used, but the swage die must be used for N3000 and HT.

(For N3000) (For HT)

SA

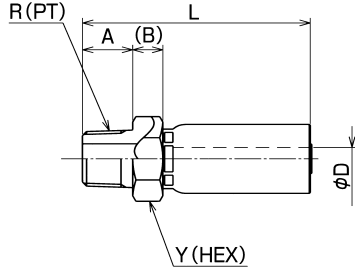

Part No.	Size No.	R	A	B	Min. I.D. ϕD	L	Y (HEX)	Weight (g)	Pusher	Die
SA-PT-04	04	1/4	13	8.5	3.9	61	19	60	PSA-04	SPN-04
SA-PT-06-N30	06	3/8	15	9.0	6.8	67	22	90	PSA-06	SPN-06
SA-PT-08-N30	08	1/2	18	10.0	10.0	76	27	140	PSA-08	SPN-08
SA-PT-10-N30	10	3/4	20	10.0	13.0	80	32	180	PSA-10	SPN-10

Material : steel
 Adapter : O30, 130

Stainless steel type

Part No.	Size No.	R	A	B	Min. I.D. ϕD	L	Y (HEX)	Weight (g)	Pusher	Die	
										First	Second
SA-PT-04-S	04	1/4	14	8.5	3.9	61	19	60	PSA-04	SPH-04-1-ST	SPN-04
SA-PT-06-N30-S	06	3/8	15	9.0	6.8	67	22	90	PSA-06	SPH-06-1-ST	SPN-06
SA-PT-08-N30-S	08	1/2	18	10.0	10.0	76	27	140	PSA-08	SPH-08-1-ST	SPN-08

Material : stainless steel SUS304
 Adapter : O30, 130

SE

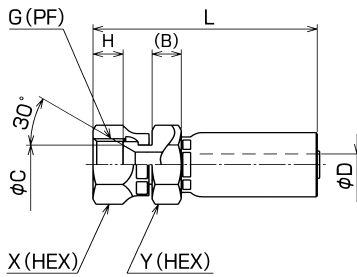

Part No.	Size No.	G	B	C	Min. I.D. ϕD	H	L	X (HEX)	Y (HEX)	Weight (g)	Pusher	Die
SE-PF-04	04	1/4	8.0	9.3	3.9	8.0	64	19	17	75	PSE-04	SPN-04
SE-PF-06-N30	06	3/8	9.5	12.3	6.8	9.5	71	22	19	110	PSE-06	SPN-06
SE-PF-08-N30	08	1/2	9.0	15.5	10.0	12.5	80	27	27	170	PSE-08	SPN-08
SE-PF-10-N30	10	3/4	10.5	21.0	13.1	13.0	84	32	32	220	PSE-10	SPN-10

Material : steel
 Adapter : O10, O45, O90, 150, O20, O25, O64, O69, O30

Stainless steel type

Part No.	Size No.	G	B	C	Min. I.D. ϕD	H	L	X (HEX)	Y (HEX)	Weight (g)	Pusher	Die	
												First	Second
SE-PF-04-S	04	1/4	8.0	9.0	3.9	8.0	64	19	19	80	PSE-04	SPH-04-1-ST	SPN-04
SE-PF-06-N30-S	06	3/8	9.5	12.5	6.8	9.5	71	22	22	110	PSE-06	SPH-06-1-ST	SPN-06
SE-PF-08-N30-S	08	1/2	9.0	15.0	10.0	12.5	80	27	27	170	PSE-08	SPH-08-1-ST	SPN-08

Material : stainless steel SUS304
 Adapter : O10, O45, O90, 150, O20, O25, O64, O69, O30

SF

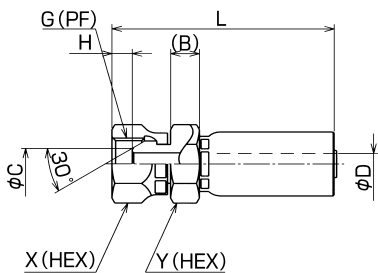

Part No.	Size No.	G	B	C	Min. I.D. ϕD	H	L	X (HEX)	Y (HEX)	Weight (g)	Pusher	Die
SF-PF-04	04	1/4	8.5	7.5	3.9	5.5	63	19	17	75	PSE-04	SPN-04
SF-PF-06-N30	06	3/8	9.5	10.0	6.8	6.5	71	22	19	110	PSE-06	SPN-06
SF-PF-08-N30	08	1/2	9.0	14.0	10.0	9.0	80	27	27	170	PSE-08	SPN-08
SF-PF-10-N30	10	3/4	10.5	19.0	13.1	9.5	84	32	32	220	PSE-10	SPN-10

Material : steel
 Adapter : 110, 145, 190, 130

Hydraulic Hose products

- Hydraulic Hose
- Airless-painting Hose
- Clean Hose
- Adapter
- Hose Guard Parts, Specially-Treated Parts
- Assembling Machine, Jig, Tool
- Hose Assembling Method
- Technical Document
- Reference Document

Hose products

[Swage type]

Caution: The size 04 coupling for N3130 can also be used, but the swage die must be used for N3000 and HT.

(For N3000) (For HT)

SO

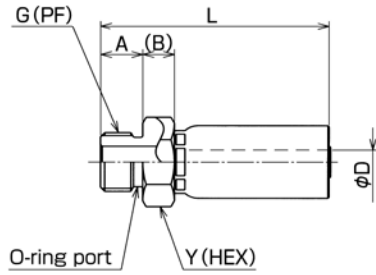

Part No.	Size No.	G	A	B	Min. I.D. φD	L	Y (HEX)	Weight (g)	Pusher	Die
SO-PF-04	04	1/4	11	8.5	3.9	59	19	55	PSA-04	SPN-04
SO-PF-06-N30	06	3/8	12	9.0	6.8	64	22	85	PSA-06	SPN-06
SO-PF-08-N30	08	1/2	15	10.0	10.0	73	27	135	PSA-08	SPN-08

- Material : steel
- O-ring : 04-JIS B2401-P11, 06-JIS B2401-P14, 08-JIS B2401-P18
- ☞ O-ring is not mounted inside.

SC

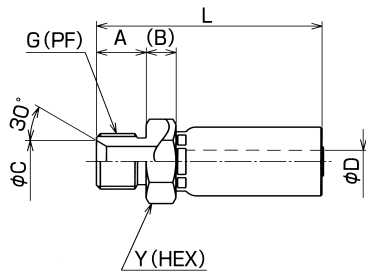

Part No.	Size No.	G	A	B	C	Min. I.D. φD	L	Y (HEX)	Weight (g)	Pusher	Die
SC-PF-04	04	1/4	13	8.5	9.5	3.9	61	19	60	PSA-04	SPN-04
SC-PF-06-N30	06	3/8	15	9.0	12.5	6.8	67	22	90	PSA-06	SPN-06
★ SC-PF-08-N30	08	1/2	18	10.0	16.5	10.0	76	27	140	PSA-08	SPN-08
★ SC-PF-10-N30	10	3/4	20	10.0	22.0	13.0	80	32	180	PSA-10	SPN-10

- Material : steel
- Adapter : 060
- ★ Made-to-order

SL

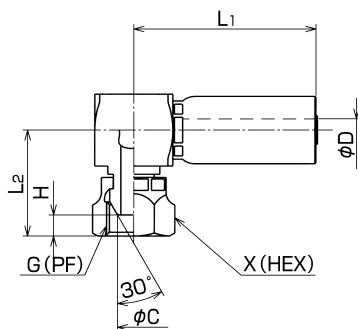

Part No.	Size No.	G	C	Min. I.D. φD	H	L1	L2	X (HEX)	Weight (g)	Pusher	Die
SL-PF-04	04	1/4	7.5	3.9	5.5	54	28	19	115	PSL-04	SPN-04
SL-PF-06-N30	06	3/8	10.0	6.8	6.5	55	33	22	160	PSL-06	SPN-06
SL-PF-08-N30	08	1/2	13.2	10.0	9.0	62	37	27	255	PSL-08	SPN-08
SL-PF-10-N30	10	3/4	19.0	13.1	9.5	69	42	32	490	PSL-12	SPN-10

- Material : steel
- Adapter : 110, 145, 190, 130, C70, C74, C79

[Swage type]

⚠ Caution : The size O4 coupling for N3130 can also be used, but the swage die must be used for N3000 and HT.

(For N3000) (For HT)

AE90, SE90

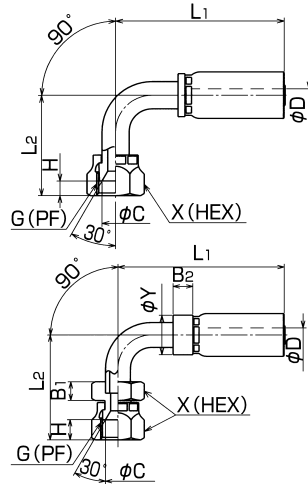

Part No.	Size No.	G	C	Min. I.D. phi D	H	L1	L2	X (HEX)	Weight (g)	Pusher	Die
AE90-G-04	04	1/4	9.0	3.2	8.0	59	33	19	75	PFB-01+PA-04	SPN-04
AE90-G-06-N30	06	3/8	12.0	5.6	9.5	73	45	22	122	PFB-01+PA-06	SPN-06
AE90-G-08-N30	08	1/2	15.5	8.7	12.5	83	52	27	189	PFB-01+PA-08	SPN-08

- Material : steel
- Adapter : 010, 045, 090, 150, 020, 025, 064, 069, 030

Part No.	Size No.	G	C	Min. I.D. phi D	H	L1	L2	X (HEX)	Weight (g)	Pusher	Die
★ SE90-PF-10-N30	10	3/4	21.0	13.1	13.0	105	76	32	354	PFB-02+PHB-12	SPN-10

- Material : steel
- Adapter : 010, 045, 090, 150, 020, 025, 064, 069, 030
- ★ Made-to-order

AF45, SF45

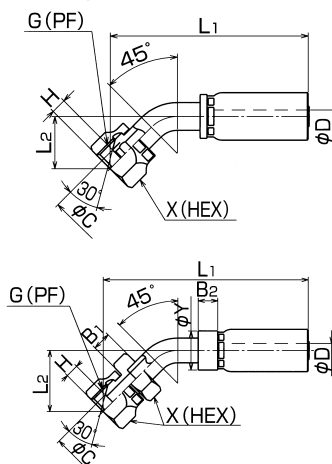

Part No.	Size No.	G	C	Min. I.D. phi D	H	L1	L2	X (HEX)	Weight (g)	Pusher	Die
AF45-G-04	04	1/4	7.0	3.2	5.5	73	19	19	70	PFB-01+PA-04	SPN-04
AF45-G-06-N30	06	3/8	10.0	5.6	6.5	85	23	22	115	PFB-01+PA-06	SPN-06
AF45-G-08-N30	08	1/2	14.0	8.7	9.0	103	29	27	185	PFB-01+PA-08	SPN-08

- Material : steel
- Adapter : 110, 145, 190, 130

Part No.	Size No.	G	C	Min. I.D. phi D	H	L1	L2	X (HEX)	Weight (g)	Pusher	Die
★ SF45-PF-10-N30	10	3/4	19.0	13.1	9.5	126	40	32	335	PFB-02+PHB-12	SPN-10

- Material : steel
- Adapter : 110, 145, 190, 130
- ★ Made-to-order

AF90, SF90

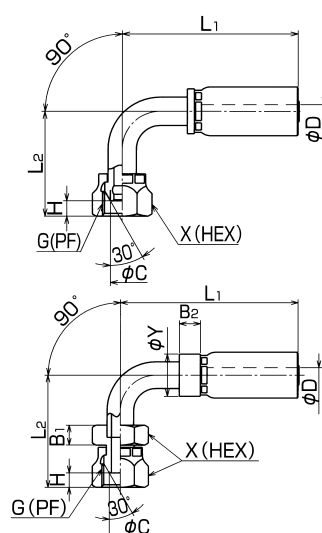

Part No.	Size No.	G	C	Min. I.D. phi D	H	L1	L2	X (HEX)	Weight (g)	Pusher	Die
AF90-G-04	04	1/4	7.0	3.2	5.5	61	33	19	75	PFB-01+PA-04	SPN-04
AF90-G-06-N30	06	3/8	10.0	5.6	6.5	74	45	22	125	PFB-01+PA-06	SPN-06
AF90-G-08-N30	08	1/2	14.0	8.7	9.0	83	52	27	190	PFB-01+PA-08	SPN-08

- Material : steel
- Adapter : 110, 145, 190, 130

Part No.	Size No.	G	C	Min. I.D. phi D	H	L1	L2	X (HEX)	Weight (g)	Pusher	Die
★ SF90-PF-10-N30	10	3/4	19.0	13.1	9.5	105	77	32	360	PFB-02+PHB-12	SPN-10

- Material : steel
- Adapter : 110, 145, 190, 130
- ★ Made-to-order

Hydraulic Hose
 Airless-painting Hose
 Clean Hose
 Adapter
 Hose Guard Parts, Specially-Treated Parts
 Assembling Machine, Jig, Tool
 Hose Assembling Method
 Technical Document
 Reference Document

3R80 Series

3R80

Features

- Excellent oil and chemical durability
- JIS K 6375 B certified, SAE 100R8 certified.

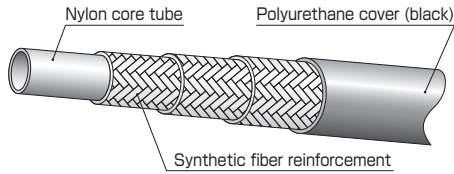

Part No.	Size			Max. working pressure		Min. burst pressure		Min. bending radius (mm)	Weight (g/m)	Coupling	
	Size No.	I.D. (in.)	I.D. (mm)	O.D. (mm)	(MPa)	(PSI)	(MPa)				(PSI)
3R80-03	03	3/16	4.8	12.7	35.0	5,050	140.0	20,200	38	115	Swage
3R80-04	04	1/4	6.3	15.5	35.0	5,050	140.0	20,200	51	175	
3R80-06	06	3/8	9.5	19.1	28.0	4,050	112.0	16,200	64	221	
3R80-08	08	1/2	12.7	22.2	25.0	3,600	98.0	14,200	102	283	
3R80-12	12	3/4	19.0	28.6	16.0	2,300	63.0	9,100	165	380	
3R80-16	16	1	25.4	36.9	14.0	2,000	56.0	8,000	254	572	

- Appropriate fluid : mineral general operating oil
- Working temperature range : -40 to +100°C
- Length in a unit package : 100m for sizes 03, 04, 05, 08, and 50m for sizes 12, 16

[Swage type]

⚠ Caution : The size 06 and 08 coupling for N3000 can also be used, but the swage die must be used for 3R80.

(For 3R80)

SA

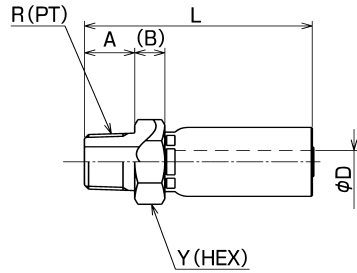

Part No.	Size No.	R	A	B	Min. I.D. ϕD	L	Y (HEX)	Weight (g)	Pusher	Die
SA-PT-03-3R	03	1/4	13	8.5	2.8	53	19	50	PSA-04	SPH-03
SA-PT-04-3R	04	1/4	13	8.5	3.9	61	19	60	PSA-04	SPH-04
SA-PT-06-N30	06	3/8	15	9.0	6.8	67	22	90	PSA-06	SPH-06
SA-PT-08-N30	08	1/2	18	10.0	10.0	76	27	140	PSA-08	SPH-08
SA-PT-12-3R	12	3/4	20	10.0	16.0	83	36	220	PSA-12	SPH-12
SA-PT-16-3R	16	1	23	10.0	20.9	100	41	340	PSA-16	SPH-16

■ Material : steel
 ■ Adapter : 030, 130

Stainless steel type

Part No.	Size No.	R	A	B	Min. I.D. ϕD	L	Y (HEX)	Weight (g)	Pusher	Die	
										First	Second
SA-PT-04-3R-S	04	1/4	14	8.5	3.9	61	19	72	PSA-04	SPH-04-1-ST	SPH-04
SA-PT-06-N30-S	06	3/8	15	9.0	6.8	67	22	90	PSA-06	SPH-06-1-ST	SPH-06
SA-PT-08-N30-S	08	1/2	18	10.0	10.0	76	27	140	PSA-08	SPH-08-1-ST	SPH-08

■ Material : stainless steel SUS304
 ■ Adapter : 030, 130

SE

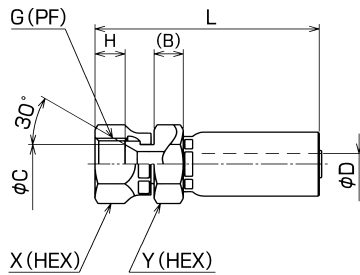

Part No.	Size No.	G	B	C	Min. I.D. ϕD	H	L	X (HEX)	Y (HEX)	Weight (g)	Pusher	Die
SE-PF-03-3R	03	1/4	6.0	9.5	2.8	8.0	55	19	19	60	PSE-03	SPH-03
SE-PF-04-3R	04	1/4	8.5	9.5	3.9	8.0	63	19	19	80	PSE-04	SPH-04
SE-PF-06-N30	06	3/8	9.5	12.3	6.8	9.5	71	22	19	110	PSE-06	SPH-06
SE-PF-08-N30	08	1/2	9.0	15.5	10.0	12.5	80	27	27	170	PSE-08	SPH-08
SE-PF-12-3R	12	3/4	10.5	21.5	16.0	13.0	87	36	36	280	PSE-12	SPH-12
SE-PF-16-3R	16	1	11.0	27.5	20.9	15.0	105	41	41	400	PSE-16	SPH-16

■ Material : steel
 ■ Adapter : 010, 045, 090, 150, 020, 025, 064, 069, 030

Stainless steel type

Part No.	Size No.	G	B	C	Min. I.D. ϕD	H	L	X (HEX)	Y (HEX)	Weight (g)	Pusher	Die	
												First	Second
SE-PF-04-3R-S	04	1/4	8.5	9.5	3.9	8.0	63	19	19	80	PSE-04	SPH-04-1-ST	SPH-04
SE-PF-06-N30-S	06	3/8	9.5	12.5	6.8	9.5	71	22	22	110	PSE-06	SPH-06-1-ST	SPH-06
SE-PF-08-N30-S	08	1/2	9.0	15.5	10.0	12.5	80	27	27	170	PSE-08	SPH-08-1-ST	SPH-08
SE-PF-12-3R-S	12	3/4	10.5	21.5	16.0	13.0	87	36	36	280	PSE-12	SPH-12-1-ST	SPH-12
SE-PF-16-3R-S	16	1	11.0	27.5	20.9	15.0	105	41	41	400	PSE-16	SPH-16-1-ST	SPH-16

■ Material : stainless steel SUS304
 ■ Adapter : 010, 045, 090, 150, 020, 025, 064, 069, 030

SF

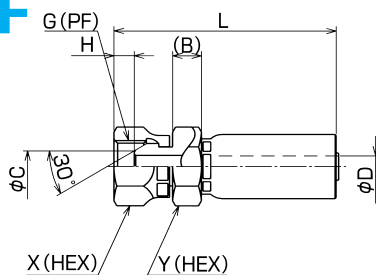

Part No.	Size No.	G	B	C	Min. I.D. ϕD	H	L	X (HEX)	Y (HEX)	Weight (g)	Pusher	Die
SF-PF-03-3R	03	1/4	6.0	7.5	2.8	5.5	55	19	19	60	PSE-03	SPH-03
SF-PF-04-3R	04	1/4	8.5	7.5	3.9	5.5	63	19	19	80	PSE-04	SPH-04
SF-PF-06-N30	06	3/8	9.5	10.0	6.8	6.5	71	22	19	110	PSE-06	SPH-06
SF-PF-08-N30	08	1/2	9.0	14.0	10.0	9.0	80	27	27	170	PSE-08	SPH-08
SF-PF-12-3R	12	3/4	10.5	19.0	16.0	9.5	87	36	36	280	PSE-12	SPH-12
SF-PF-16-3R	16	1	11.0	25.4	20.9	10.0	105	41	41	410	PSE-16	SPH-16

■ Material : steel
 ■ Adapter : 110, 145, 190, 130

SC

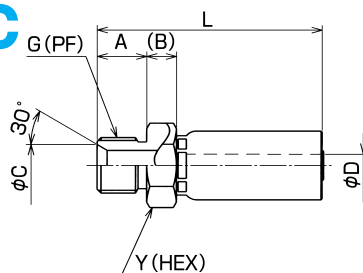

Part No.	Size No.	G	A	B	C	Min. I.D. ϕD	L	Y (HEX)	Weight (g)	Pusher	Die
★ SC-PF-03-3R	03	1/4	13	8.5	9.5	2.8	53	19	50	PSA-04	SPH-03
SC-PF-04-3R	04	1/4	13	8.5	9.5	3.9	61	19	60	PSA-04	SPH-04
SC-PF-06-N30	06	3/8	15	9.0	12.5	6.8	67	22	90	PSA-06	SPH-06
★ SC-PF-08-N30	08	1/2	18	10.0	16.5	10.0	76	27	140	PSA-08	SPH-08

■ Material : steel
 ■ Adapter : 060
 ★Made-to-order

Hydraulic Hose
 Airless-painting Hose
 Clean Hose
 Adapter
 Hose Guard Parts, Specially-Treated Parts
 Assembling Machine, Jig, Tool
 Hose Assembling Method
 Technical Document
 Reference Document

Hose products

5501 Series of electrostatic-free type

5501

Features

- Electrostatic free
- Excellent chemical durability
- Flexible and tough
- External-damage durability because of stainless wire braid in the reinforcement layer

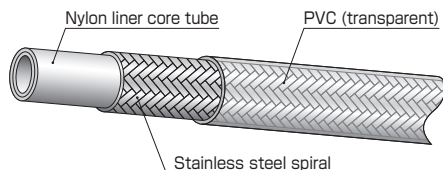

Part No.	Size			Max. working pressure		Min. burst pressure		Min. bending radius (mm)	Weight (g/m)	Coupling	
	Size No.	I.D. (in.)	I.D. (mm)	O.D. (mm)	(MPa)	(PSI)	(MPa)				(PSI)
5501-04-CL	04	1/4	6.0	10.6	21.0	3,000	70.0	10,200	50	110	Swage
5501-06-CL	06	3/8	9.0	14.8	21.0	3,000	70.0	10,200	80	220	Swage

- Appropriate fluid : paint, thinner
 - Working temperature range : -10 to +60°C
 - Assembly of couplings with hose is to be done at our factory.
- 🔗 "CL" stands for clear.

3450 Series of conductive polymer structure type

3450

Features

- Wireless structure in conductive polymer layer
- Lightweight
- High chemical durability

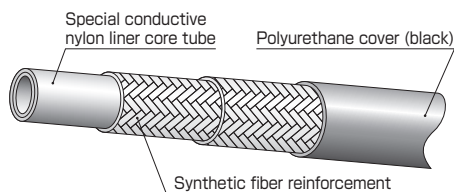

Part No.	Size			Max. working pressure		Min. burst pressure		Min. bending radius (mm)	Weight (g/m)	Coupling	
	Size No.	I.D. (in.)	I.D. (mm)	O.D. (mm)	(MPa)	(PSI)	(MPa)				(PSI)
★ 3450-03	03	3/16	4.8	10.8	23.0	3,350	92.0	13,400	25	71	
★ 3450-04	04	1/4	6.3	13.2	23.0	3,350	92.0	13,400	25	95	Swage
★ 3450-06	06	3/8	9.5	18.5	21.0	3,000	84.0	12,000	60	195	

- Appropriate fluid : paint, thinner
 - Working temperature range : -40 to +80°C
 - Assembly of couplings with hose is to be done at our factory.
- ★ Made-to-order

[Swage type]

(For 5501)

SF (for 5501)

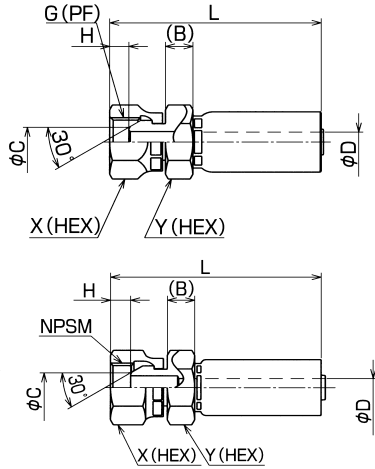

Part No.	Size No.	G or NPSM	B	C	Min. I.D. φD	H	L	X (HEX)	Y (HEX)	Weight (g)
SF-PF-04-55	04	G1/4	8.5	7.5	3.3	5.5	60	19	17	80
SF-NPSM-04-55	04	NPSM1/4	8.5	7.5	3.3	5.5	60	19	17	80
SF-PF-06-5501	06	G3/8	9.5	10.0	6.2	6.5	71	22	22	110
SF-NPSM-06-5501	06	NPSM3/8	9.5	10.0	6.2	6.5	71	22	22	110

- Material : steel
- Adapter : 110, 145, 190, 130 *Not suitable for NPSM.
- Assembly of couplings with hose is to be done at our factory.

(For 3450)

SF (for 3450)

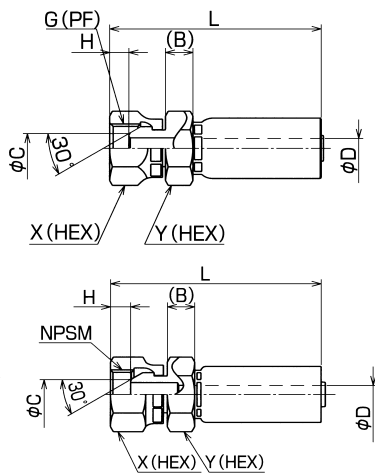

Part No.	Size No.	G or NPSM	B	C	Min. I.D. φD	H	L	X (HEX)	Y (HEX)	Weight (g)
SF-PF-03	03	G1/4	6.0	7.5	2.8	5.5	58	19	19	70
★ SF-NPSM-03-3450	03	NPSM1/4	6.0	7.5	3.0	4.0	56	19	19	70
SF-PF-04	04	1/4	8.5	7.5	3.9	5.5	63	19	17	75
★ SF-NPSM-04	04	NPSM1/4	8.5	7.5	4.0	5.5	63	19	19	80
SF-PF-06-N30	06	3/8	9.5	10.0	6.8	6.5	71	22	19	110

- Material : steel
- Adapter : 110, 145, 190, 130
- Assembly of couplings with hose is to be done at our factory.
- ★ Made-to-order

Hydraulic hose products

- Hydraulic Hose
- Airless-painting Hose
- Clean Hose
- Adapter
- Hose Guard Parts, Specially-Treated Parts
- Assembling Machine, Jig, Tool
- Hose Assembling Method
- Technical Document
- Reference Document

34PW Series

For pure water, urethane forming m/c, food, or drinking water

34PW

Features

- High water-barrier performance
- Excellent chemical durability
- Anti-taint property
- The core tubing material complies with NSF and No.370 of the Ministry of Health and Welfare, Japan.

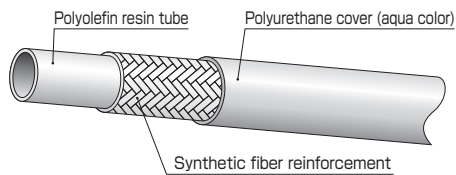

Part No.	Size			Max. working pressure		Min. burst pressure		Min. bending radius (mm)	Weight (g/m)	Coupling	
	Size No.	I.D. (in.)	I.D. (mm)	O.D. (mm)	(MPa)	(PSI)	(MPa)				(PSI)
34PW-02-LBU	02	1/8	3.6	8.3	20.0	2,900	80.0	11,600	25	45	Swage
34PW-04-LBU	04	1/4	6.3	12.5	19.5	2,850	78.0	11,400	30	95	
34PW-06-LBU	06	3/8	9.5	16.4	16.0	2,300	64.0	9,200	50	134	
34PW-08-LBU	08	1/2	12.7	20.3	14.0	2,000	56.0	8,000	75	201	
34PW-12-LBU	12	3/4	19.0	28.7	10.5	1,500	42.0	6,000	125	368	
34PW-16-LBU	16	1	25.4	36.5	10.5	1,500	42.0	6,000	200	554	

■ Appropriate fluid : pure water, chemicals (isocyanate), etc.

■ Working temperature range : -30 to +70°C

■ Assembly of couplings with hose is to be done at our factory.

🔗 Each pressure in the above table represents a pressure with the use of a PW coupling.

🔗 "LBU" stands for light blue.

[Swage type]

(For 34PW)

SE (PW coupling)

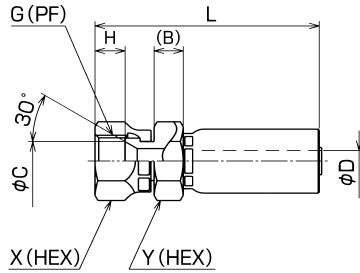

Stainless steel type (SUS316)

Part No.	Size No.	G	B	C	Min. I.D. ϕD	H	L	X (HEX)	Y (HEX)	Weight (g)	Pusher	Die	
												First	Second
SE-G-04-PW	04	1/4	8.5	9.0	4.0	8.0	63	19	19	80	PSE-04	SP3-04-VC	-
SE-G-06-PW	06	3/8	9.5	12.0	6.9	9.0	71	22	22	110	PSE-06	SP3-06-VC	-
SE-G-08-PW	08	1/2	9.0	15.5	10.0	12.5	80	27	27	170	PSE-08	SP3-08-VC	-
SE-G-12-PW	12	3/4	10.0	21.0	16.0	13.5	86	36	36	270	PSE-12	SPH-12-1-ST	SPH-12-VC
SE-G-16-PW	16	1	11.0	28.0	20.9	16.5	105	41	41	410	PSE-16	SPH-16-1-ST	SPH-16-37VC

- Material : stainless steel SUS316
- Assembly of couplings with hose is to be done at our factory.
- Ultrasonic cleaning is available only for the couplings, if required. Contact us for details.
- As for the steel couplings; sizes 04, 06, and 08 for N3130 series, and sizes 12 and 16 for 3R80 can also be used.

SE (PWL coupling) for under 7.0 MPa

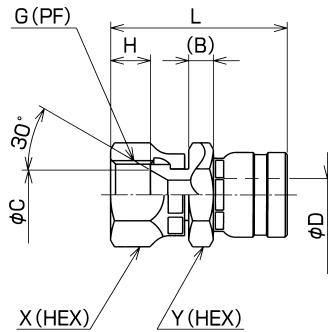

Stainless steel type (SUS316)

Part No.	Size No.	G	B	C	Min. I.D. ϕD	H	L	X (HEX)	Y (HEX)	Weight (g)	Pusher	Die	
												First	Second
SE-G-04-PWL	04	1/4	6.0	9.0	5.0	8.0	42	19	19	60	PSE-04-PWL	SPP-04-VC	-
SE-G-06-PWL	06	3/8	6.0	12.0	8.0	9.5	44	22	22	70	PSE-06-PWL	SPP-06-VC	-
SE-G-08-PWL	08	1/2	8.0	15.5	11.0	12.5	54	27	27	130	PSE-08-PWL	SPP-08-VC	-
SE-G-12-PWL	12	3/4	10.0	21.0	16.0	13.5	64	36	36	230	PSE12-PWL	SPP-12-VC	-
SE-G-16-PWL	16	1	10.0	28.0	22.0	16.5	67	41	41	310	PSE-16-PWL	SPP-16-VC	-

- Maximum working pressure (static pressure) : 7.0MPa
- Material : stainless steel SUS316
- Assembly of couplings with hose is to be done at our factory.
- Ultrasonic cleaning is available only for the couplings, if required. Contact us for details.
- As for the steel couplings; sizes 04, 06, and 08 for N3130 series, and sizes 12 and 16 for 3R80 can also be used.

SE

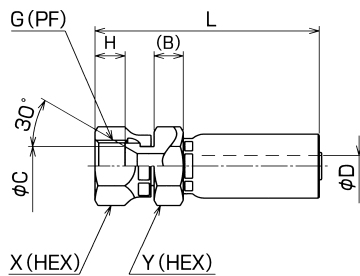

Stainless steel type (SUS304)

Part No.	Size No.	G	B	C	Min. I.D. ϕD	H	L	X (HEX)	Y (HEX)	Weight (g)	Pusher	Die	
												First	Second
SSE-PF-02-S	02	1/8	4.0	7.0	1.8	7.0	42	14	14	25	PSE-02-001	SP3-02-001	-
SE-PF-04-S	04	1/4	8.5	9.5	3.9	8.0	63	19	19	80	PSE-04	SP3-04-1-ST	SP3-04
SE-PF-06-S	06	3/8	9.5	12.5	6.8	9.5	71	22	22	110	PSE-06	SP3-06-1-ST	SP3-06
SE-PF-08-S	08	1/2	9.0	16.0	10.0	12.0	80	27	27	170	PSE-08	SP3-08-1-ST	SP3-08
SE-PF-12-3R-S	12	3/4	10.5	21.5	16.0	13.0	87	36	36	280	PSE-12	SPH-12-1-ST	SPH-12
SE-PF-16-3R-S	16	1	11.0	27.5	20.9	15.0	105	41	41	400	PSE-16	SPH-16-1-ST	SPH-16

- Material : stainless steel SUS304
- Assembly of couplings with hose is to be done at our factory.
- Ultrasonic cleaning is available only for the couplings, if required. Contact us for details.
- As for the steel coupling, size 02 for 3130 series, sizes 04, 06, and 08 for N3130 series, and sizes 12 and 16 for 3R80 can also be used.

Adapter for 34PW

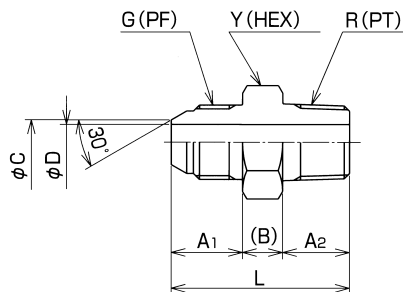

Stainless steel type (SUS316)

Part No.	Size No.	G	R	A ₁	A ₂	B	C	Min. I.D. ϕD	L	Y (HEX)	Weight (g)
010-06-06-PW	06	3/8	3/8	16	15	9.0	10.0	8.0	40	22	60
010-08-08-PW	08	1/2	1/2	19	18	10.0	13.0	11.0	47	27	100
010-12-12-PW	12	3/4	3/4	21	20	12.0	19.0	16.0	53	36	180
010-16-16-PW	16	1	1	23	23	13.0	25.0	22.0	59	41	250

- Material : stainless steel SUS316
- Ultrasonic cleaning is available only for the couplings, if required. Contact us for details.

Hydraulic Hose
Airless-painting Hose
Clean Hose

Adapter

Hose Guard Parts, Specially-Treated Parts

Assembling Machine, Jig, Tool

Hose Assembling Method

Technical Document

Reference Document

Adapter

Adapter



Assembling method
▶▶▶ p.74

Specification

Material : Steel, SUS304, SUS316

Usage conditions

Appropriate fluid : Mineral hydraulic oil

Maximum working pressure : It changes with the size of G- and A-threads, and when different sizes exist in one product, the larger one is to be counted.

02 to 08 : 35.0MPa
12 : 27.5MPa
16 : 20.5MPa

Working temperature range : -55°C to +120°C

Example of part number

010-04-04-(S)

Adapter shape
see the next page

Size of G(PF) thread
02 = 1/8" 08 = 1/2"
04 = 1/4" 12 = 3/4"
06 = 3/8" 16 = 1"

Size of R(PT) or G(PF)
02 = 1/8" 08 = 1/2"
04 = 1/4" 12 = 3/4"
06 = 3/8" 16 = 1"

Material
No indication = Steel
S = SUS304

Adapter shapes chart

Taper thread type to equipment side (with 30° female seat)

Straight type **45° elbow type** **90° elbow type** **Female-thread straight type**

110

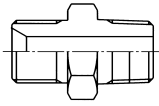

145

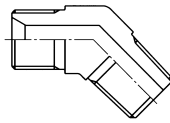

190

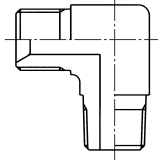

130

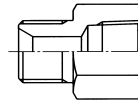

Taper thread type to equipment side (with 30° male seat)

Straight type **45° elbow type** **90° elbow type** **Female-thread straight type** **Parallel male-thread type**

010

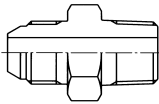

045

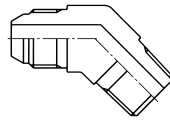

090

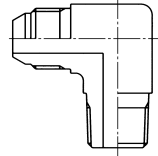

030

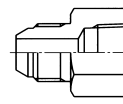

060

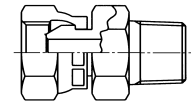

Taper thread screw type to equipment side (with 30° male seat)

Straight type **45° elbow type** **Thread screw bolt**

010-001

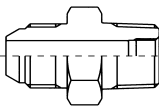

090-001

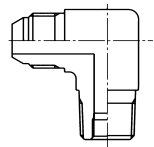

007



Interconnection type (with 30° male seat)

Straight type **Panel touch straight type** **Panel touch 90° straight type** **45° bend type** **90° bend type**

150

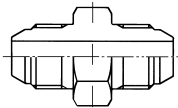

020

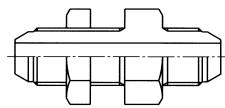

025

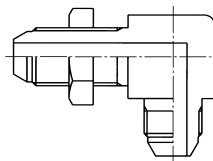

064

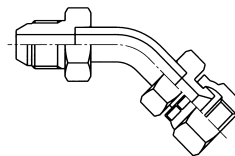

069

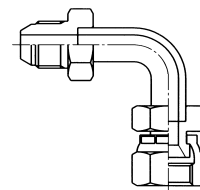

Contact us for other shapes.

Hydraulic Hose	Airless-painting Hose	Clean Hose
Hydraulic hose products		
Adapter		
Hose Guard Parts, Specially-Treated Parts		
Assembling Machine, Jig, Tool		
Hose Assembling Method		
Technical Document		
Reference Document		

Adapter

[Taper thread type to equipment side] (with 30° female seat)

110

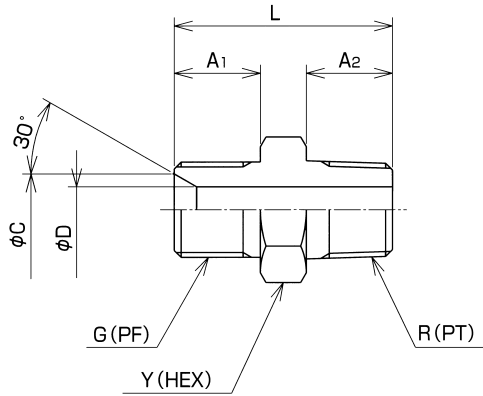

Part No.	G	R	A ₁	A ₂	C	D	L	Y (HEX)	Weight (g)
110-02-02	1/8	1/8	10	10	7.0	3.0	28	14	20
110-02-04	1/8	1/4	10	13	7.0	3.0	31	19	30
110-04-02	1/4	1/8	13	10	9.5	5.0	31	19	30
110-04-04	1/4	1/4	13	13	9.5	5.0	34	19	35
110-04-06	1/4	3/8	13	15	9.5	5.0	36	22	50
110-06-04	3/8	1/4	15	13	12.5	8.0	36	22	50
110-06-06	3/8	3/8	15	15	12.5	8.0	38	22	55
110-06-08	3/8	1/2	15	18	12.5	8.0	43	27	90
110-08-06	1/2	3/8	18	15	16.0	11.0	43	27	90
110-08-08	1/2	1/2	18	18	16.0	11.0	46	27	100
110-08-12	1/2	3/4	18	20	16.0	11.0	50	36	165
110-12-08	3/4	1/2	20	18	21.5	16.0	50	36	165
110-12-12	3/4	3/4	20	20	21.5	16.0	52	36	175
110-12-16	3/4	1	20	22	21.5	16.0	54	41	235
110-16-12	1	3/4	22	20	27.5	22.0	56	41	235
110-16-16	1	1	22	22	27.5	22.0	57	41	245

Material : steel

Stainless steel type

Part No.	G	R	A ₁	A ₂	C	D	L	Y (HEX)	Weight (g)
110-02-02-S	1/8	1/8	10	10	7.0	3.0	28	14	20
110-04-04-S	1/4	1/4	13	13	9.5	5.0	34	19	35
110-06-06-S	3/8	3/8	15	15	12.5	8.0	38	22	55
110-08-08-S	1/2	1/2	18	18	16.0	11.0	46	27	100
110-12-12-S	3/4	3/4	20	20	21.5	16.0	52	36	175
110-16-16-S	1	1	22	22	27.5	22.0	57	41	245

Material : stainless steel SUS304

Hose couplings : SF, SL, SF45, SF90, AF45, AF90, CF, F

145

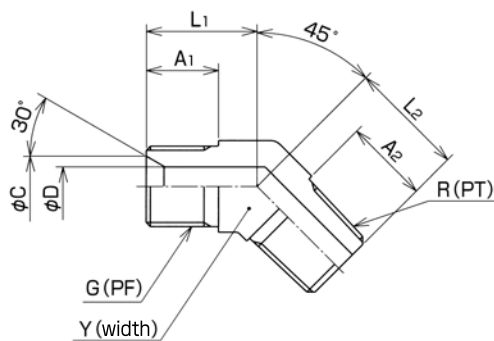

Part No.	G	R	A ₁	A ₂	C	D	L ₁	L ₂	Y (width)	Weight (g)
145-02-02	1/8	1/8	14	14	7.0	3.0	18	18	14	20
★ 145-02-04	1/8	1/4	10	13	7.0	3.0	18	20	17	35
★ 145-04-02	1/4	1/8	13	14	9.0	5.5	19	20	17	36
145-04-04	1/4	1/4	13	14	9.0	5.5	19	20	17	40
★ 145-04-06	1/4	3/8	13	18	9.0	5.5	18	24	19	55
★ 145-06-04	3/8	1/4	15	14	12.5	8.0	23	21	19	57
145-06-06	3/8	3/8	15	15	12.5	8.0	23	24	19	65
★ 145-06-08	3/8	1/2	15	18	12.5	8.0	23	27	24	99
★ 145-08-06	1/2	3/8	18	15	16.0	11.0	26	24	24	95
145-08-08	1/2	1/2	18	22	15.5	11.0	26	27	24	100
★ 145-08-12	1/2	3/4	18	20	16.0	16.0	26	32	30	170
★ 145-12-08	3/4	1/2	20	18	21.5	16.0	32	27	30	170
145-12-12	3/4	3/4	20	20	21.5	16.0	32	32	30	190
★ 145-12-16	3/4	1	20	22	21.5	22.0	32	34	36	264
★ 145-16-12	1	3/4	22	20	27.5	22.0	35	32	36	250
145-16-16	1	1	22	22	27.5	22.0	35	34	36	275

Material : steel

★Made-to-order

Hose couplings : SF, SL, SF45, SF90, AF45, AF90, CF, F

[Taper thread type to equipment side] (with 30° female seat)

190

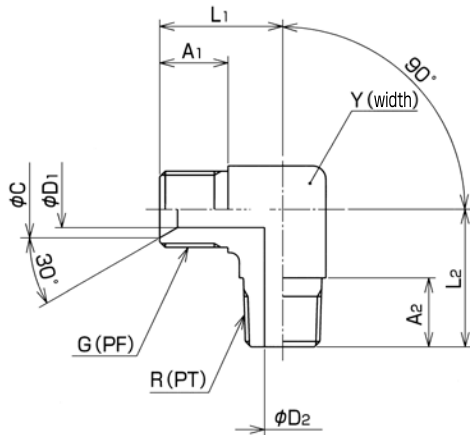

Part No.	G	R	A ₁	A ₂	C	D ₁	D ₂	L ₁	L ₂	Y (width)	Weight (g)
190-02-02	1/8	1/8	9	14	7.0	3.0	4.0	18	22	14	30
190-02-04	1/8	1/4	10	13	7.0	3.0	5.0	20	27	17	50
190-04-02	1/4	1/8	13	10	9.5	6.0	4.0	25	20	17	45
190-04-04	1/4	1/4	13	13	9.5	5.0	5.0	23	27	17	50
190-04-06	1/4	3/8	13	18	9.5	5.0	8.0	25	30	19	80
190-06-04	3/8	1/4	15	16	12.5	8.0	5.0	27	28	19	75
190-06-06	3/8	3/8	15	15	12.5	8.0	8.0	27	30	19	145
190-06-08	3/8	1/2	15	22	12.5	8.0	11.0	28	38	24	140
190-08-06	1/2	3/8	18	20	16.0	11.0	8.0	31	32	24	140
190-08-08	1/2	1/2	18	18	16.0	11.0	11.0	31	38	24	165
190-08-12	1/2	3/4	18	24	16.0	11.0	16.0	34	43	30	250
190-12-08	3/4	1/2	20	22	21.5	16.0	11.0	36	41	30	250
190-12-12	3/4	3/4	20	20	21.5	16.0	16.0	36	43	30	265
190-12-16	3/4	1	20	22	21.5	16.0	22.0	40	46	36	400
190-16-12	1	3/4	22	20	27.5	22.0	16.0	42	44	36	400
190-16-16	1	1	22	22	27.5	22.0	22.0	42	46	36	460

Material : steel

Stainless steel type

Part No.	G	R	A ₁	A ₂	C	D ₁	D ₂	L ₁	L ₂	Y (HEX)	Weight (g)
190-02-02-S	1/8	1/8	10	10	7.0	3.0	3.0	18	22	14	30
190-04-04-S	1/4	1/4	13	13	9.5	5.0	5.0	23	27	17	50
190-06-06-S	3/8	3/8	15	15	12.5	8.0	8.0	27	30	19	145
190-08-08-S	1/2	1/2	18	18	16.0	11.0	11.0	31	38	24	165
190-12-12-S	3/4	3/4	20	20	21.5	16.0	16.0	36	43	30	265

Material : stainless steel SUS304

Hose couplings : SF, SL, SF45, SF90, AF45, AF90, CF, F

130

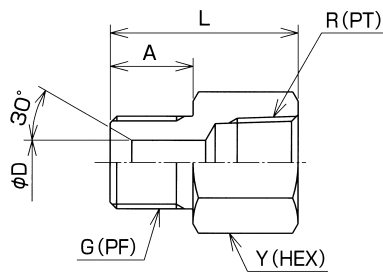

Part No.	G	R	A	C	D	L	Y (HEX)	Weight (g)
130-02-02	1/8	1/8	10	7.0	3.0	25	14	18
130-04-04	1/4	1/4	13	9.5	5.5	30	19	36
130-06-06	3/8	3/8	15	12.5	8.0	34	22	52
130-08-08	1/2	1/2	18	16.0	11.0	40	27	88
130-12-12	3/4	3/4	20	21.5	16.0	45	36	175
130-16-16	1	1	22	27.5	22.0	50	41	221

Material : steel

Hose couplings : SA, SF, SL, SF45, SF90, AF45, AF90, CA, CF, A, F

- Hydraulic Hose
- Airless-painting Hose
- Clean Hose
- Adapter
- Hose Guard Parts, Specially-Treated Parts
- Assembling Machine, Jig, Tool
- Hose Assembling Method
- Technical Document
- Reference Document

Adapter

[Taper thread type to equipment side] (with 30° female seat)

010

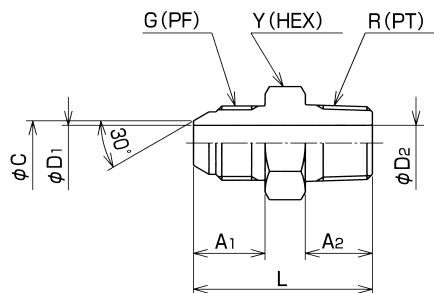

Part No.	G	R	A ₁	A ₂	C	D ₁	D ₂	L	Y (HEX)	Weight (g)
010-02-02	1/8	1/8	12	10	4.5	3.0	3.0	30	14	20
010-02-04	1/8	1/4	12	13	4.5	3.0	5.5	34	17	30
010-04-02	1/4	1/8	14	10	7.5	5.5	3.0	32	19	30
010-04-04	1/4	1/4	14	13	7.5	5.5	5.5	35	19	35
010-04-06	1/4	3/8	14	15	7.5	5.5	8.0	37	22	50
010-06-04	3/8	1/4	16	13	10.0	8.0	5.5	39	22	50
010-06-06	3/8	3/8	16	15	10.0	8.0	8.0	40	22	55
010-06-08	3/8	1/2	16	18	10.0	8.0	11.0	44	27	85
010-08-06	1/2	3/8	19	15	13.0	11.0	8.0	44	27	85
010-08-08	1/2	1/2	19	18	13.0	11.0	11.0	47	27	95
010-08-12	1/2	3/4	19	20	13.0	11.0	16.0	53	36	160
010-12-08	3/4	1/2	21	18	19.0	16.0	11.0	51	36	160
010-12-12	3/4	3/4	21	20	19.0	16.0	16.0	53	36	170
010-12-16	3/4	1	21	22	19.0	16.0	22.0	56	41	230
010-16-12	1	3/4	23	20	25.0	22.0	16.0	56	41	230
010-16-16	1	1	23	22	25.0	22.0	22.0	58	41	235

Material : steel

Stainless steel type

Part No.	G	R	A ₁	A ₂	C	D ₁	D ₂	L	Y (HEX)	Weight (g)
010-02-02-S	1/8	1/8	12	10	4.5	3.0	3.0	30	14	20
010-04-04-S	1/4	1/4	14	13	7.5	5.5	5.5	35	19	35
010-06-06-S	3/8	3/8	16	15	10.0	8.0	8.0	40	22	55
010-08-08-S	1/2	1/2	19	18	13.0	11.0	11.0	47	27	95
010-12-12-S	3/4	3/4	21	20	19.0	16.0	16.0	53	36	170
010-16-16-S	1	1	23	22	25.0	22.0	22.0	58	41	235

Material : stainless steel SUS304

Hose couplings : SE, SLE, SE45, SE90, AE45, AE90, CE, E

045

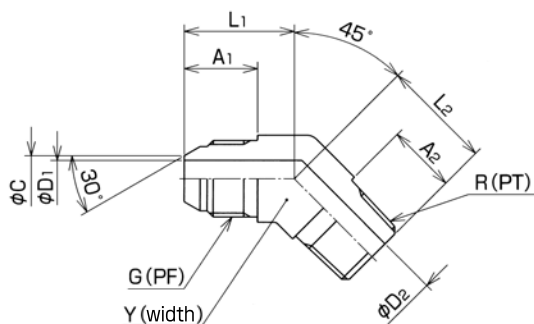

Part No.	G	R	A ₁	A ₂	C	D ₁	D ₂	L ₁	L ₂	Y (width)	Weight (g)
045-02-02	1/8	1/8	12	10	4.5	3.0	3	18	18	14	20
045-02-04	1/8	1/4	12	13	4.5	3.0	5	20	20	17	35
045-04-02	1/4	1/8	14	14	7.5	5.0	3	22	18	17	35
045-04-04	1/4	1/4	14	13	7.5	5.0	5	22	20	17	40
045-04-06	1/4	3/8	14	18	7.0	5.0	8	22	24	19	60
045-06-04	3/8	1/4	16	13	10.0	8.0	5	24	20	19	60
045-06-06	3/8	3/8	16	15	10.0	8.0	8	24	24	19	65
045-06-08	3/8	1/2	16	22	10.0	8.0	11	24	27	24	90
045-08-06	1/2	3/8	20	18	13.0	11.0	8	27	24	24	90
045-08-08	1/2	1/2	19	18	13.0	11.0	11	27	27	24	100
045-08-12	1/2	3/4	19	23	13.0	11.0	16	27	32	30	160
045-12-08	3/4	1/2	21	22	19.0	16.0	11	32	27	30	170
045-12-12	3/4	3/4	21	23	19.0	16.0	16	32	32	30	190
045-12-16	3/4	1	21	26	19.0	16.0	22	32	34	36	265
045-16-12	1	3/4	23	20	25.0	22.0	16	35	32	36	265
045-16-16	1	1	23	22	25.0	22.0	22	35	34	36	295

Material : steel

Stainless steel type

Part No.	G	R	A ₁	A ₂	C	D ₁	D ₂	L ₁	L ₂	Y (width)	Weight (g)
★ 045-04-04-S	1/4	1/4	14	13	7.5	5.0	5	22	20	17	40
★ 045-06-06-S	3/8	3/8	16	15	10.0	8.0	8	24	24	19	65
★ 045-08-08-S	1/2	1/2	19	18	13.0	11.0	11	27	27	24	100
★ 045-12-12-S	3/4	3/4	21	20	19.0	16.0	16	32	32	30	190
★ 045-16-16-S	1	1	23	22	25.0	22.0	22	35	34	36	295

Material : stainless steel SUS304

★Made-to-order

Hose couplings : SE, SLE, SE45, SE90, AE45, AE90, CE, E

[Taper thread type to equipment side] (with 30° male seat)

090

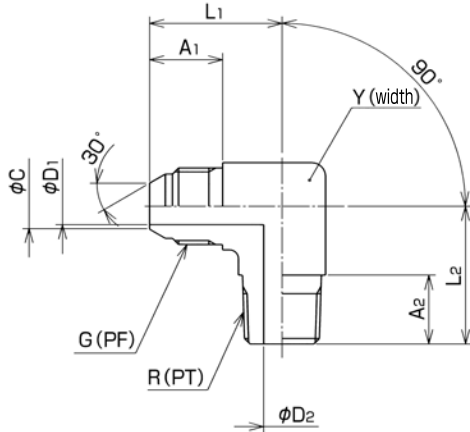

Part No.	G	R	A ₁	A ₂	C	D ₁	D ₂	L ₁	L ₂	Y (width)	Weight (g)
090-02-02	1/8	1/8	12	12	4.5	3.0	4	22	22	14	30
090-02-04	1/8	1/4	12	13	4.5	3.0	5	23	27	17	45
090-04-02	1/4	1/8	14	10	7.5	5.0	3	24	23	17	45
090-04-04	1/4	1/4	14	13	7.5	5.0	5	24	27	17	50
090-04-06	1/4	3/8	14	18	7.5	5.5	8	29	30	19	80
090-06-04	3/8	1/4	16	13	10.0	8.0	5	29	27	19	75
090-06-06	3/8	3/8	16	15	10.0	8.0	8	29	30	19	80
090-06-08	3/8	1/2	16	18	10.0	8.0	11	29	38	24	145
090-08-06	1/2	3/8	18	18	13.0	11.0	8	33	30	24	140
090-08-08	1/2	1/2	20	22	13.0	11.0	11	33	38	24	165
090-08-12	1/2	3/4	19	24	13.0	11.0	16	36	43	30	250
090-12-08	3/4	1/2	21	22	19.0	16.0	11	36	38	30	250
090-12-12	3/4	3/4	21	20	19.0	16.0	16	36	43	30	265
090-12-16	3/4	1	23	25	19.0	16.0	22	42	46	36	400
090-16-12	1	3/4	23	24	25.0	22.0	16	42	43	36	400
090-16-16	1	1	23	22	25.0	22.0	22	42	46	36	400

Material : steel

Stainless steel type

Part No.	G	R	A ₁	A ₂	C	D ₁	D ₂	L ₁	L ₂	Y (width)	Weight (g)
090-02-02-S	1/8	1/8	12	10	4.5	3.0	4	22	22	14	30
090-04-04-S	1/4	1/4	14	13	7.5	5.0	5	24	27	17	50
090-06-06-S	3/8	3/8	16	15	10.0	8.0	8	29	30	19	80
090-08-08-S	1/2	1/2	19	18	13.0	11.0	11	33	38	24	165
090-12-12-S	3/4	3/4	21	19	19.0	16.0	16	36	43	30	265

Material : stainless steel SUS304

Hose couplings : SE, SLE, SE45, SE90, AE45, AE90, CE, E

030

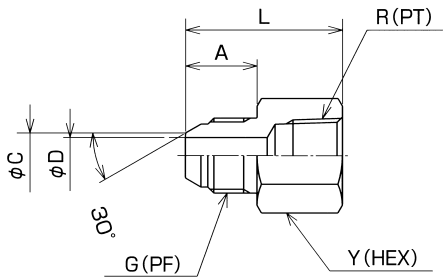

Part No.	G	R	A	C	D	L	Y (HEX)	Weight (g)
030-02-02	1/8	1/8	12	4.5	3.0	27	14	20
030-04-04	1/4	1/4	14	7.5	5.5	30	19	25
030-06-06	3/8	3/8	16	10.0	8.0	35	22	55
030-08-08	1/2	1/2	19	13.0	11.0	41	27	75
030-12-12	3/4	3/4	21	19.0	16.0	46	36	160
030-16-16	1	1	23	25.0	22.0	51	41	220

Material : steel

Stainless steel type

Part No.	G	R	A	C	D	L	Y (HEX)	Weight (g)
★ 030-02-02-S	1/8	1/8	12	4.5	3.0	27	14	20
★ 030-04-04-S	1/4	1/4	14	7.5	5.5	30	19	25
★ 030-06-06-S	3/8	3/8	16	10.0	8.0	35	22	55
★ 030-08-08-S	1/2	1/2	19	13.0	11.0	41	27	75
★ 030-12-12-S	3/4	3/4	21	19.0	16.0	46	36	160
★ 030-16-16-S	1	1	23	25.0	22.0	51	41	220

Material : stainless steel SUS304

★Made-to-order

Hose couplings : SA, SE, SLE, SE45, SE90, AE45, AE90, CA, CE, A, E

060

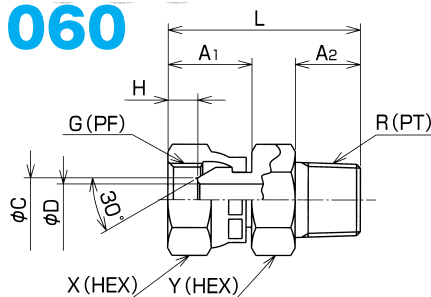

Part No.	G	R	A ₁	A ₂	C	Min. I.D. phi D	H	L	X (HEX)	Y (HEX)	Weight (g)
060-02-02	1/8	1/8	16.0	11	5.0	2.8	3.0	35	14	14	25
060-04-04	1/4	1/4	17.0	13	7.0	5.0	5.5	38	19	19	50
060-06-06	3/8	3/8	19.0	15	10.0	7.2	6.5	44	22	22	80
060-08-08	1/2	1/2	23.5	18	13.2	11.0	9.5	52	27	27	115
060-12-12	3/4	3/4	23.5	21	19.0	16.0	9.5	57	36	36	220
060-16-16	1	1	27.0	23	25.4	21.5	10.0	63	41	41	300

Material : steel

Hose couplings : SC

Hydraulic Hose
 Airless-painting Hose
 Clean Hose
 Adapter
 Hose Guard Parts, Specially-Treated Parts
 Assembling Machine, Jig, Tool
 Hose Assembling Method
 Technical Document
 Reference Document

Adapter

[Taper thread screw type to equipment side] (with 30° male seat)

010 screw

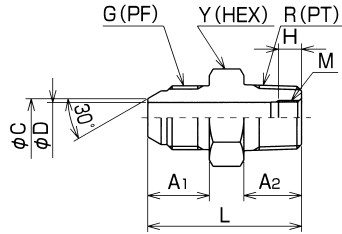

Part No.	G	R	A ₁	A ₂	C	D	H	L	M	Y (HEX)	Weight (g)
★ 010-04-04-001	1/4	1/4	14	13	7.5	5.5	6.0	35	M7×0.75	19	35
★ 010-06-06-001	3/8	3/8	16	15	10.0	8.0	6.0	40	M9×0.75	22	55
★ 010-08-08-001	1/2	1/2	19	18	13.0	11.0	7.5	47	M12×1	27	90
★ 010-12-12-001	3/4	3/4	21	20	19.0	16.0	8.5	53	M17×1	36	170

■ Material : steel
★Made-to-order

Hose couplings : SE, SLE, SE45, SE90, AE45, AE90, CE, E

090 screw

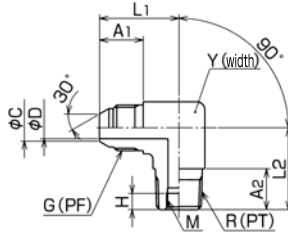

Part No.	G	A ₁	A ₂	C	D	H	L ₁	L ₂	Y (width)	M	Weight (g)
★ 090-04-04-001	1/4	14	13	7.5	5	6.0	24	27	17	M7×0.75	50
★ 090-06-06-001	3/8	16	15	10.0	8	6.0	29	30	19	M9×0.75	90
★ 090-08-08-001	1/2	20	22	13.0	11	7.5	33	38	24	M12×1	145
★ 090-12-12-001	3/4	21	20	19.0	16	8.5	36	43	30	M17×1	260

■ Material : steel
★Made-to-order

Hose couplings : SE, SLE, SE45, SE90, AE45, AE90, CE, E

Bolt for fixed screw adapter

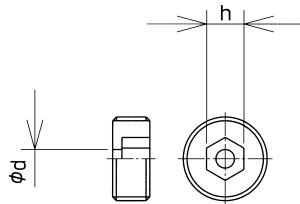

Part No.	Adapter 1	Adapter 2	h	φd	Weight (g)
★ 007-04-0.5	010-04-04-001	090-04-04-001	3	0.5	1.0
★ 007-04-0.7	010-04-04-001	090-04-04-001	3	0.7	1.0
★ 007-04-1.0	010-04-04-001	090-04-04-001	3	1.0	1.0
★ 007-04-1.5	010-04-04-001	090-04-04-001	3	1.5	1.0
★ 007-04-2.0	010-04-04-001	090-04-04-001	3	2.0	1.0
★ 007-06-0.5	010-06-06-001	090-06-06-001	4	0.5	1.5
★ 007-06-0.7	010-06-06-001	090-06-06-001	4	0.7	1.5
★ 007-06-1.0	010-06-06-001	090-06-06-001	4	1.0	1.5
★ 007-06-1.5	010-06-06-001	090-06-06-001	4	1.5	1.5
★ 007-08-0.5	010-08-08-001	090-08-08-001	6	0.5	3.0
★ 007-08-0.7	010-08-08-001	090-08-08-001	6	0.7	3.0
★ 007-08-1.0	010-08-08-001	090-08-08-001	6	1.0	3.0
★ 007-08-1.5	010-08-08-001	090-08-08-001	6	1.5	3.0
★ 007-08-2.0	010-08-08-001	090-08-08-001	6	2.0	3.0
★ 007-08-2.5	010-08-08-001	090-08-08-001	6	2.5	3.0
★ 007-12-1.5	010-12-12-001	090-12-12-001	8	1.5	8.0
★ 007-12-2.0	010-12-12-001	090-12-12-001	8	2.0	8.0
★ 007-12-2.5	010-12-12-001	090-12-12-001	8	2.5	8.0
★ 007-12-3.0	010-12-12-001	090-12-12-001	8	3.0	8.0

■ Material : brass
★Made-to-order

[Interconnection type] (with 30° male seat)

150

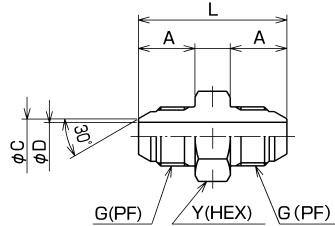

Part No.	G	A	C	D	L	Y (HEX)	Weight (g)
150-02-02	1/8	12	4.5	3.0	31	14	15
150-04-04	1/4	14	7.5	5.5	36	19	50
150-06-06	3/8	16	10.0	8.0	42	22	75
150-08-08	1/2	19	13.0	11.0	48	27	85
150-12-12	3/4	21	19.0	16.0	54	36	160
150-16-16	1	23	25.0	22.0	59	41	230

■ Material : steel

Hose couplings : SE, SLE, SE45, SE90, AE45, AE90, CE, E

020 panel touch

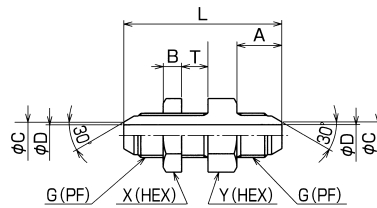

Part No.	G	A	B	C	D	L	T (max. panel thickness)	X (HEX)	Y (HEX)	Mounting nut	Weight (g)
★ 020-04-04-001	1/4	14	7.0	7.5	5	54	10	22	22	NP04	75
★ 020-06-06-001	3/8	17	7.0	10.0	8	60	10	24	24	NP06	105
★ 020-08-08-001	1/2	19	10.0	13.0	11	71	10	30	30	NP08	190
★ 020-12-12-001	3/4	21	10.0	19.0	16	79	10	41	41	NP012	365
★ 020-16-16-001	1	23	12.0	25.0	22	87	10	46	46	NP016	505

■ Material : steel
★ Made-to-order

Hose couplings : SE, SLE, SE45, SE90, AE45, AE90, CE, E

025 panel touch

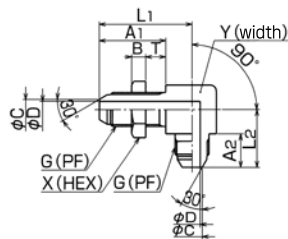

Part No.	G	A ₂	A ₂	B	C	D	L ₁	L ₂	T (max. panel thickness)	X (HEX)	Y (width)	Mounting nut	Weight (g)
★ 025-04-04	1/4	32	15	7.0	7.0	5.5	45	26	10	22	22	NP04	125
★ 025-06-06	3/8	33	16	7.0	10.0	8.0	46	29	10	24	24	NP06	160
★ 025-08-08	1/2	40	19	10.0	13.0	11.0	59	35	10	30	30	NP08	320

■ Material : steel
★ Made-to-order

Hose couplings : SE, SLE, SE45, SE90, AE45, AE90, CE, E

064

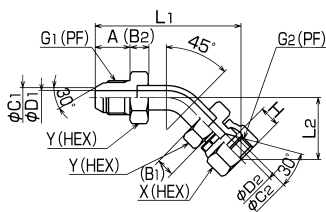

Part No.	G ₁	G ₂	A	B ₁	B ₂	C ₁	C ₂	D ₁	D ₂	H	L ₁	L ₂	X (HEX)	Y (HEX)	Pipe size	Weight (g)
★ 064-04	1/4	1/4	15	8.5	8.5	9.0	9.0	5.0	5.0	8.0	63	26	19	19	φ10×t2	85
★ 064-06	3/8	3/8	17	9.0	9.0	12.0	12.0	7.0	7.0	9.5	72	30	22	22	φ12×t2	120
★ 064-08	1/2	1/2	20	9.5	9.5	15.5	15.5	10.0	10.0	12.5	82	32	27	27	φ15×t2.5	200
★ 064-12	3/4	3/4	21	11.0	10.5	19.0	21.0	16.0	16.0	13.5	95	40	36	36	φ20×t2.5	350
★ 064-16	1	1	23	12.5	12.5	28.0	28.0	21.5	21.5	16.5	108	47	41	41	φ28×t3.5	515

■ Material : steel
★ Made-to-order

Hose couplings : SE, SLE, SE45, SE90, AE45, AE90, CE, E

069

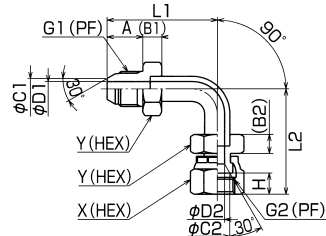

Part No.	G ₁	G ₂	A	B ₁	B ₂	C ₁	C ₂	D ₁	D ₂	H	L ₁	L ₂	X (HEX)	Y (HEX)	Pipe size	Weight (g)
★ 069-04	1/4	1/4	15	8.5	8.5	7.0	9.0	5.0	5.0	8.0	46	45	19	19	φ10×t2	90
★ 069-06	3/8	3/8	17	9.0	9.0	10.0	12.0	7.0	7.0	9.5	53	50	22	22	φ12×t2	125
★ 069-08	1/2	1/2	20	9.5	9.5	13.0	15.5	10.0	10.0	12.5	62	55	27	27	φ15×t2.5	205
★ 069-12	3/4	3/4	21	11.0	10.5	19.0	21.0	16.0	16.0	13.5	74	76	36	36	φ20×t2.5	375
★ 069-16	1	1	23	12.0	12.5	25.0	28.0	21.5	21.5	16.5	83	87	41	41	φ28×t3.5	565

■ Material : steel
★ Made-to-order

Hose couplings : SE, SLE, SE45, SE90, AE45, AE90, CE, E

- Hydraulic Hose
- Airless-painting Hose
- Clean Hose
- Adapter
- Hose Guard Parts, Specially-Treated Parts
- Assembling Machine, Jig, Tool
- Hose Assembling Method
- Technical Document
- Reference Document

Hose protection parts /

Specially-treated hoses

Double hoses and triple hoses

MADE
TO
ORDER



● **Two hoses can be adhered together.**

If you use double hoses,

- the piping space can be made compact.
- a single reel pulley suffices.
- hose flopping at pressurization can be minimized.

 Adhesion of more than three hoses or adhesion with tubes is also possible. Contact us for details.

Nonconductive (electric insulating) processing

MADE
TO
ORDER

Although plastic hoses are generally electrically insulated, sometimes leakage current is regulated for hydraulic hoses of electrical work equipment or for the hoses that are especially required to be insulated. When electrical insulation is required, we can make a hose cover with no pin-pricking processing (no pin hole processing for gas venting) in order to prevent the reduction of electrical insulation due to external water invasion.

 Contact us for details.

special processed parts

Outer braid processing

MADE TO ORDER

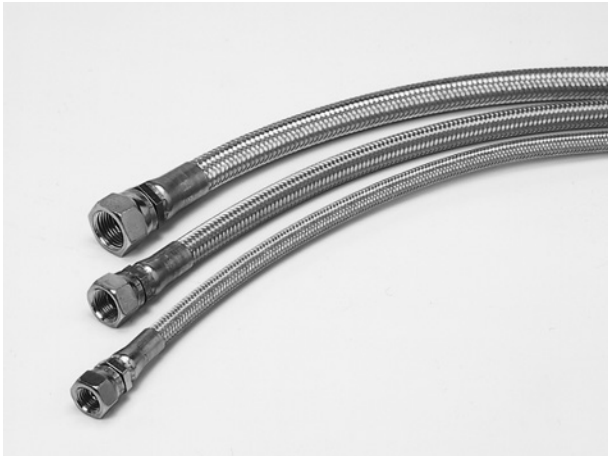

- **Processing of steel wire braid and stainless wire braid is possible.**

- Guarding hose against powdery metal.
- Maintaining electric conductivity
- Guarding hose against damage

Colored hose

MADE TO ORDER



- **Hose cover can be colored.**

- Coloring hoses (blue, red, gray, green, aqua color, etc)

 Contact us for details.

Hydraulic hose products

Hydraulic
HoseAirless-painting
Hose

Clean Hose



Adapter

Hose Guard
Parts, Specially-
Treated PartsAssembling
Machine,
Jig, ToolHose
Assembling
MethodTechnical
DocumentReference
Document

Hose protection parts / special processed parts

Hose guard parts

Hose guard parts attached

- 
① Covering whole hose The whole hose is covered.
- 
② Covering both ends Both ends of the coupling are covered. Please specify the length.
- 
③ Covering single end One end of the coupling is covered. Please specify the length and direction.

For more details, see "How to order horse assembly" on page 5.

Guard spring



Features

- It prevents kinks and flattening of the hose.
- It prevents abrasion and damage to the hose.

Specification

Material : steel

- Expand the spring 2-2.5 times the original length when in use.
- Attach the spring by screwing over the coupling socket with the hand.
- The spring can also be made of SUS304 or SUS316 , please consult us if you need them.

Working temperature range

Same as the working temperature range of the hose.

Part number

G1 : For whole hose
 G2 : For both ends
 G3 : For single end

Specify the length for G2 and G3.

For single part order

Contact us.

Unit length : 1.7 m in contracted state

For LF70 series

Part No.	Hose size	Spring O.D. (mm)	Spring wire diameter (mm)
YM07-04-MCH-1700L	04	15.3	1.6
YM07-06-MCH-1700L	06	19.1	2.0

For 1000, 1400, 1500 series

Part No.	Hose size	Spring O.D. (mm)	Spring wire diameter (mm)
YM10-03-MCH-1700L	03	12.9	1.4
YM10-04-MCH-1700L	04	15.8	1.6
YM10-06-MCH-1700L	06	19.6	2.0
YM10-08-MCH-1700L	08	23.0	2.0

For 1100 series

Part No.	Hose size	Spring O.D. (mm)	Spring wire diameter (mm)
YM11-04-MCH-1700L	04	15.8	1.6
YM11-06-MCH-1700L	06	19.6	2.0
YM11-08-MCH-1700L	08	23.7	2.0

For N3130, 3130, 3700, 3000, 34PW (04, 06, 08) series

Part No.	Hose size	Spring O.D. (mm)	Spring wire diameter (mm)
YMS-02-MCH-1700L	02	11.6	1.4
YMS-03-MCH-1700L	03	15.4	1.6
YMS-04-MCH-1700L	04	18.2	2.0
YMS-05-MCH-1700L	05	19.6	2.0
YMS-06-MCH-1700L	06	21.2	2.0
YMS-08-MCH-1700L	08	25.1	2.0
YMS-12-MCH-1700L	12	34.9	2.6
YMS-16-MCH-1700L	16	39.1	2.6

For N3000, HT series

Part No.	Hose size	Spring O.D. (mm)	Spring wire diameter (mm)
YMS-04-MCH-1700L	04	18.2	2.0
YMSN-06-MCH-1700L	06	22.4	2.0
YMSN-08-MCH-1700L	08	26.2	2.0
YMSN-10-MCH-1700L	10	31.7	2.6

For 3R80, 34PW (12, 16) series

Part No.	Hose size	Spring O.D. (mm)	Spring wire diameter (mm)
YMSH-03-MCH-1700L	03	17.3	2.0
YMSH-04-MCH-1700L	04	20.5	2.0
YMSH-06-MCH-1700L	06	23.7	2.0
YMSH-08-MCH-1700L	08	28.1	2.6
YMSH-12-MCH-1700L	12	35.6	2.9
YMSH-16-MCH-1700L	16	43.2	2.9

Nylon spiral tube



Features

- It prevents abrasion and damage to the hose
- Light
- It can be attached after piping
- For binding hoses
- Excellent chemical durability

Specification

Material : nylon Polyethylene spiral tube is also available. Contact us for details.
Color : black

Working temperature range

Nylon : -40°C to +105°C
Polyethylene : -40°C to +85°C

Part number

S1 : For whole hose
S2 : For both ends
S3 : For single end

Specify the length for S2 and S3.

For single part order

Contact us.

Unit length : SPN-06-0 100M
SPN-11-0, SPN-18-0 50M

Part No.	Outer X inner diameters (mm)	Thickness (mm)	Pitch (mm)	Recommended hose size
SPN-06-0-100M	5.5×4	0.75	10	02~04
SPN-11-0-50M	10.6×9	0.8	12	03~08
SPN-18-0-50M	16.6×15	0.8	18	08~16

Heat contraction tube



Features

- As an insulator from outside
- For binding multiple hoses
- For preventing abrasion and damage to the hose

Specification

Material : EPR
Color : black

Working temperature range

-50°C to +80°C

Part number

E1 : For whole hose
E2 : For both ends
E3 : For single end

Specify the length for E2 and E3.

For single part order

Contact us.

Unit length : 5M

Part No.	Inner diameter before heat contraction (mm)	Inner diameter after heat contraction (mm)	Thickness after heat contraction (mm)
H990-NT200-5M	20	10.0	1
H990-NT250-5M	25	12.5	1
H990-NT300-5M	30	15.0	1
H990-NT400-5M	40	20.0	1

Hydraulic Hose
Airless-painting Hose
Clean Hose

Adapter

Hose Guard
Parts, Specially-Treated Parts

Assembling Machine, Jig, Tool

Hose Assembling Method

Technical Document

Reference Document

Hose assembly machine and tool,

Hose assembly tools

Although Nitta plastic hoses and couplings are produced under thorough quality control, they should be correctly assembled to maximize the full potential. Please read the instructions for the use of assembling machines, tools, pushers, and dies, and assemble the hose parts with care. For details, please see the product instruction manual.

Assembling tool Mark 10

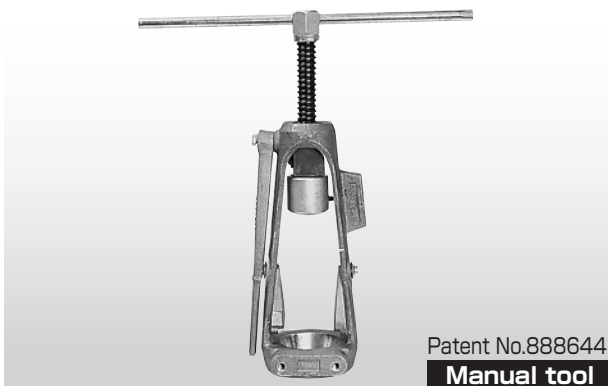

Features

- Light and easy to carry
- Anywhere, anyplace, for assembling operation

Specification

Weight : 4kg
Size : W118 × L 118 × H330mm
Material : aluminum die casting

Mark 10 can be used in the following three ways :

- (1) Fixed on a vice
- (2) Laid on the floor (with rear cushion arm and ratchet wrench HEX32)

Assembling method

▶▶▶ p.59

⚠ CAUTION

Since it is aluminum die casting, strong impact incurred when dropped Will cause damage to the body. Please handle with care.

Assembling machine Mark 9



Features

- Significant reduction of the operation time
- Beneficial for assembling a large quantities

Specification

Motor power : 200V, three-phase, 2.2 kw (3 horse power)
Hydraulic pump : Max pressure 14.3 MPa
Working pressure 11.2 Mpa
(relief pressure already set)
Working oil : turbine oil VG46 or the equivalent
Hydraulic cylinder : double-acting special cylinder
stroke 150 mm

Weight : 90kg
Size : W520 × L820 × H800mm

Assembling method

▶▶▶ p.61

special jigs and tools

Hose assembly jigs and tools

The followings are assembly jigs and tools for Mark 9 and 10.

Pusher



This is a jig to fix the sleeve of the hose coupling when assembling.

List of suitable part numbers
▶▶▶ p.63

Die

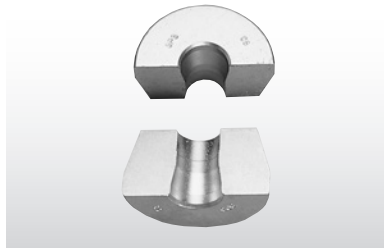

This is a jig to swage the socket of the hose coupling when assembling.

List of suitable part numbers
▶▶▶ p.63

Hand hose cutter



Part number: HC03
This can cut hoses from sizes 02 to 08.

Hose cutter



Part number : HC01
This can cut all hose sizes. There are bolt holes in the base to fix the cutter to a work surface.

Holding die (vice block)

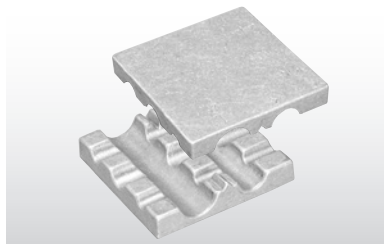

Part number : HD01 (for 03, 04, 05, 06, 08)
HD02 (for 08, 12, 16)
This is used to fix hoses in place.
☞ Use Size 02 at the position of 3/16 of HD01.

Assembly lubricant



Part number :
For assembling steel connectors : PG3740 (Nihon Kohsakyu) (lubricant color : green)
For assembling stainless connectors : CFH68 (Nisseki Mitsubishi) (lubricant color : yellow)
Content: 500 ml

This is used when you insert a hose into a hose connector or swage connectors with assembling tools.

Campucka coupling detachable jig



Part number : TRL

Hose coupling cap seal

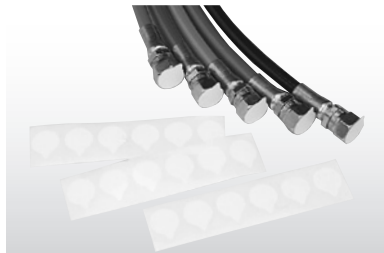

☞ Contact us for details.

CAUTION

If the recommended lubricant is not applied, coating damage and/or socket buckling may occur.

HC01 Handling Instructions

1. Fix the HC01 to a stable work surface.
2. Remove the blade fixing spring to open the cutter.
3. Set the hose into the U-shaped support.

CAUTION Do not use with any resin hoses other than the ones manufactured by Nitta.
WARNING Do not touch the cutting edge of the cutter. Also, do not place your hand near the cutting edge of the cutter. Doing so is dangerous because it may cause injury.

CAUTION Cut the hose so that the cut surface is at right angles. If the hose is cut diagonally, there is a risk of causing malfunction due to insufficient hose insertion.
CAUTION Avoid cutting a wire braid hose such as an 1100 series hose. It may cause nicks in the blade.

Use a commercially available wire cutter to cut a wire braid hose.

4. Push down the cutter handle to press-cut the hose.

CAUTION Do not use with any resin hoses other than the ones manufactured by Nitta.
WARNING Do not touch the cutting edge of the cutter. Also, do not place your hand near the cutting edge of the cutter. Doing so is dangerous because it may cause injury.

5. When not using the cutter or when temporarily stopping work, fix the blade in closed position with the blade fixing spring so that the blade is not exposed.

WARNING Leaving the cutter with the blade exposed or not closed with the fixing spring is very dangerous.

Hydraulic hose products	Hydraulic Hose
	Airless-painting Hose
	Clean Hose
Adapter	
Hose Guard Parts, Specially-Treated Parts	
Assembling Machine, Jig, Tool	
Hose Assembling Method	
Technical Document	
Reference Document	

Hose assembly method

Campucka couplings

Hose Assembling Methods

1 Preparation

Prepare appropriate hose, coupling cutter, white pen, torque wrench, seal tape, and detachable jig.



CAUTION

If the Campucka is dropped, the nipple part may detach and the hose cannot be inserted. Handle with care.

2 Attaching Campucka to equipment



Type CA
Roll seal tape onto the taper thread and connect it to the taper female thread of the equipment with proper torque.

Type CE
Attach an adapter to the equipment and the Campucka to the adapter with proper torque.

● proper torque

(N·m)

Thread size	Taper thread, R thread	Parallel thread, G thread	Thread size	Taper thread, R thread	Parallel thread, G thread
1/8	10~15	15	3/8	45~50	34
1/4	25~30	25	1/2	60~70	59

CAUTION More torque than recommendation may damage the coupling.

CAUTION When using a Campucka coupling, mark the hose to check the inserted length, fitting the hose edge to the groove mark of the socket.

CAUTION The Campucka coupling can be used only for specified hoses.

Hose No.	Hose clamp position
3130-02, F3130-02	200mm以上
1000-04, 1400-04, F3130-04	350mm以上
1000-06, 1400-06, F3130-06	400mm以上
1000-08, F3130-08	500mm以上

3 Hose cutting



WARNING

Do not touch the blade of the cutter.

CAUTION

The slanted cut section may cause pullout of the hose and leakage.

CAUTION

If the blade is blunt, the hose cut section becomes elliptic, causing pullout of the nipple O-ring on insertion and leakage. Change the cutter in this case.

Use the specified hose cutter to cut the hose squarely.

4 Marking the insertion length of the hose



As shown in the figure, mark the hose with a white pen, fitting the hose edge to the groove mark of the socket.

5 Inserting the hose to the Campucka

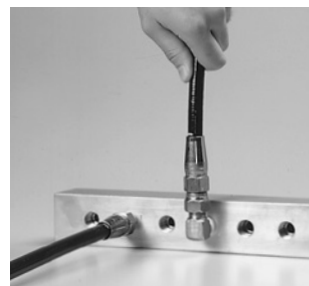

Insert the hose into the coupling until it meets the marked position. Repeat the same steps 2-5 for the other end of the Campucka.

WARNING If the insertion is insufficient, pullout of the hose or leakage may occur.

CAUTION If the hose is inserted in a tilted position, the inner part (gripper) may be deformed, interfering with the insertion.

6 Completing hose assembling



Pressurization swages the hose with an appropriate force according to the pressure.

● hose displacement by the pressurization

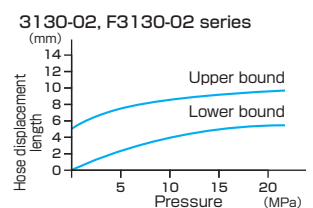
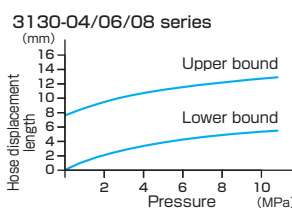
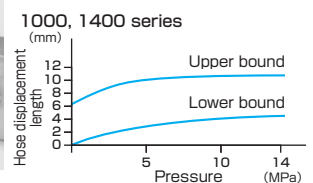

CAUTION Since displacement by the pressurization makes the hose longer, check for interference with the equipment and kinks in the hose.

Hydraulic Hose	Airless-painting Hose	Clean Hose	Adapter	Hose Guard Parts, Specially-Treated Parts	Assembling Machine, Jig, Tool	Hose Assembling Method	Technical Document	Reference Document
----------------	-----------------------	------------	---------	---	-------------------------------	-------------------------------	--------------------	--------------------

7 Detaching hose (1)

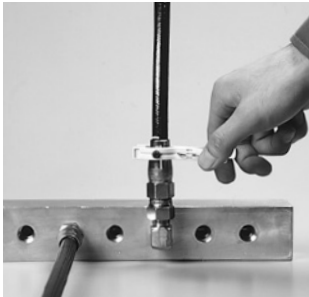

Detaching method (detachable only before pressurization)
 Insert the (two) edge pins of the detachable jig into the side holes of the socket.

8 Detaching hose (2)

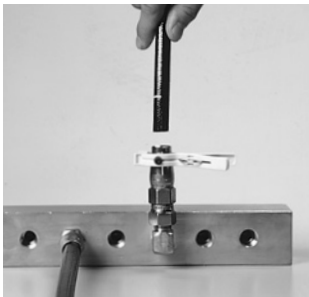

Push the hose toward the Campucka and then slowly pull it out.

- CAUTION** The hose cannot be pulled out after pressurization. If it is forced, the inner part of the coupling could be damaged, causing pullout of the hose or leakage.
- CAUTION** The hose and the Campucka are not reusable once pressurized.

* Do not pull the hose before pressurization.

Hose assembly method

Swage coupling (with Mark 10)

Setup and specifications

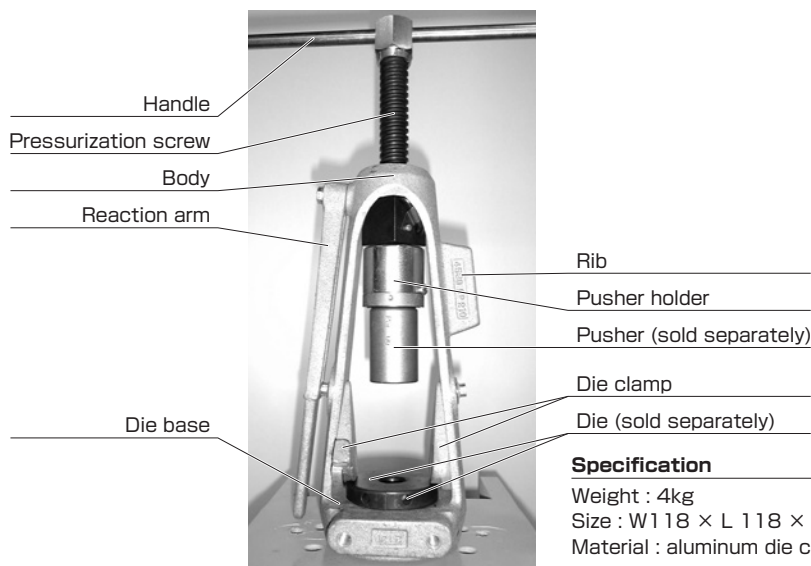

There are two ways to set Mark 10 as follows:

1 Fixed on vice (recommended)

Fix the rib of Mark 10 with a vice. (In this document, we follow this way of setting.)

2 Laid on floor

Lay Mark 10 with the support of the reaction arm.

Specification

Weight : 4kg
 Size : W118 × L 118 × H330mm
 Material : aluminum die casting

Assembling method

1 Preparation

Prepare appropriate hose, swage coupling, pusher, die, hose cutter, holding die, lubricant*, plastic hammer, scale, and white pen.



* lubricant...
 Steel coupling : Nihon Kosakuyu PG3740
 Stainless coupling :
 size O2-12 : JX Nippon Oil & Energy CFH68
 size 16 : JX Nippon Oil & Energy DPX100

☞ A 50cc bottle of lubricant (for steel coupling) comes with a set.

CAUTION If the recommended lubricant is not applied, coating damage and/or socket buckling may occur.

2 Hose cutting



Determine the cutting length of the hose based on the hose assembling length and cut the hose squarely using the special hose cutter.

* When cutting a wire braided hose such as 1100 series hose, secure the portion to be cut with plastic tape, etc. in advance in order to prevent the wire from breaking into pieces after cutting, and then cut the secured portion with a commercially available wire cutter, etc. Note that you need to remove the plastic tape before inserting the hose into a fitting.

WARNING Do not touch the blade of the cutter.

CAUTION The slanted cut section may cause pullout of the hose and leakage.

CAUTION If the blade is blunt, correct assembly is not possible. Change the hose cutter in this case.

3 Marking the insertion length of the hose



Measure the insertion length of the hose with a scale and mark the hose at the insertion length with the white pen.

☞ It is recommended to draw a marking line with a width of about 2 mm in order to check it after swaging.

4 Preparation for the hose insertion



Apply the lubricant to the inner surface of the hose and insert the coupling to the marked position. When it is difficult, use the holding die to fix the hose and hit the coupling with the plastic hammer.

CAUTION If the insertion is incomplete, pullout of the hose, leakage, or damage may occur.

5 Fixing Mark 10



Fix the rib of Mark 10 on the vice and pull out the pressurization screw to the longest position. The die clamp should be open as shown in the figure.

CAUTION If you release your grip, the pusher holder will come down by its own weight. Take care not to trap your fingers.

6 Attachment of pusher

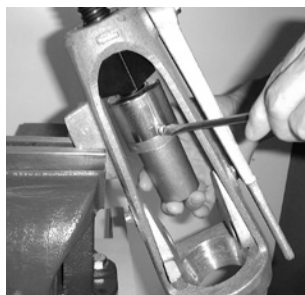

Attach the pusher to the pusher holder. Fix the pusher by turning the screw of the pusher holder with the hand so that the pusher can freely rotate. Check if the pusher is really able to rotate.

CAUTION The wrong choice of pusher will cause pullout of the hose, leakage, or damage.

7 Application of lubricant

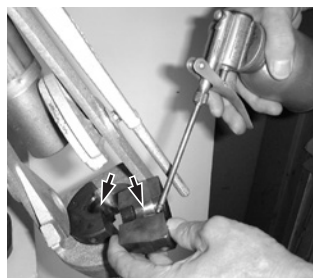

Apply lubricant to the inner surface of the die.

* Lubricant...
Steel coupling : Nihon Kosakuyu PG3740
Stainless coupling :
size 02-12 : JX Nippon Oil & Energy CFH68
size 16 : JX Nippon Oil & Energy DPX100

CAUTION

If the recommended lubricant is not applied, coating damage and/or socket buckling may occur.

8 Fixing a mate of the die



Fix a mate of the die onto the tapered base.

CAUTION

The wrong choice of pusher will cause pullout of the hose, leakage, or damage.

9 Insertion to pusher



Insert the coupling, to which the hose is inserted, into the pusher.

10 Fixing the other mate of the die



Put the other mate of the die on the base. Turn the die clamp to lock the die and fix it firmly.

CAUTION

Do not put your hand in the die.

11 Adjustment of positions of die and coupling



Hold the hose beneath the die base with your left hand. Pushing the coupling toward the pusher, turn the pressurization screw clockwise with your right hand to send the pusher down. As the pusher comes down, adjust the positions of the die hole and the coupling edge so they coincide.

CAUTION

Discrepancy of the positions of the die hole and the coupling edge might cause damage to the coupling, such as socket defect.

12 Rotating handle



Do not over-tighten the screw.

Attach the handle to the pressurization screw and rotate the handle clockwise to send the pusher down. Continue until the pusher touches the die.

CAUTION If you stop before the pusher touches the die, the swaging is insufficient and pullout of the hose or leakage may occur.

CAUTION If you do not stop rotating the handle even after the pusher reaches the die, the tool may crash.

CAUTION Do not take your hands off the handle abruptly. The handle will return in a dangerous fashion.

CAUTION For safe operation, do not get your hands trapped.

13 Detaching hose assembly



Un-install the die clamp, rotate the pressurization screw anti-clockwise to send the pusher up, and remove the hose assembly from the die. If it is difficult to remove the assembly, gently tap the die with the plastic hammer.

CAUTION

Pay strict attention to prevent the die from falling.

14 Completion of hose assembling



CAUTION

Before putting the die in storage, remove dust from the inner surface and thinly grease it to prevent rust.

15 Check of hose assembly

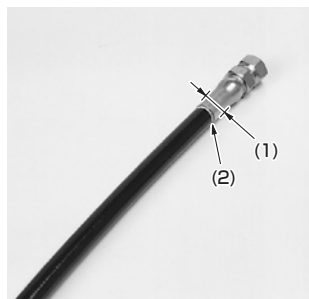

(1) Check the swage diameter (see p.81).

(2) Check the mark position of the hose insertion length.

(3) Check the appearance of the coupling. (Check for any damage or misalignment of the track of the die.)

(4) Check the appearance of the hose. (Check for any kink or cut.)

Should problems occur, do not use the hose assembly.

For details such as maintenance, please read the instruction manual that comes with the product.

Hydraulic Hose

Airless-painting Hose

Clean Hose

Adapter

Hose Guard Parts, Specially-Treated Parts

Assembling Machine, Jig, Tool

Hose Assembling Method

Technical Document

Reference Document

Hose assembly method

Swage coupling (with Mark 9)

Setup and specifications

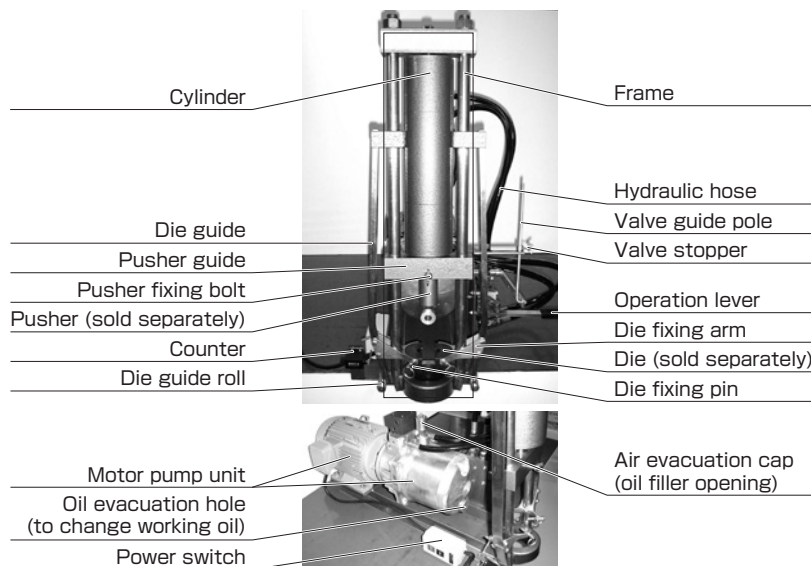

Specifications

Weight : 90kg
 Size : 520×820×800mm
 Electric motor : three phase 200V 2.2kw
 Hydraulic pump : Max. pressure 14.3 MPa
 Working pressure 11.2 MPa
 (Relief pressure already set)
 Hydraulic cylinder : Double-acting special
 cylinder stroke 150 mm
 Working oil : turbine oil VG46 or equivalent

For details such as setting-up and electric wiring, please read the instruction manual that comes with the product.

Assembling method

1 Preparation

Prepare appropriate hose, swage coupling, pusher, die, hose cutter, holding die, lubricant*, plastic hammer, scale, and white pen.



* lubricant...
 Steel coupling : Nihon Kosakuyu PG3740
 Stainless coupling :
 size 02-12 : JX Nippon Oil & Energy CFH68
 size 16 : JX Nippon Oil & Energy DPX100

A 50cc bottle of lubricant (for steel coupling) comes with a set.

CAUTION If the recommended lubricant is not applied, coating damage and/or socket buckling may occur.

2 Hose cutting



Determine the cutting length of the hose based on the hose assembling length and cut the hose squarely using the special hose cutter.

WARNING Do not touch the blade of the cutter.

CAUTION The slanted cut section may cause pullout of the hose and leakage.

CAUTION If the blade is blunt, correct assembly is not possible. Change the hose cutter in this case.

3 Marking the insertion length of the hose



Measure the insertion length of the hose with a scale and mark the hose at the insertion length with the white pen.

It is recommended to draw a marking line with a width of about 2 mm in order to check it after swaging.

4 Preparation for the hose insertion



Apply the lubricant to the inner surface of the hose and insert the coupling to the marked position. When it is difficult, use the holding die to fix the hose and hit the coupling with the plastic hammer.

CAUTION If the insertion is incomplete, pullout of the hose, leakage, or damage may occur.

5 Lifting pusher holder

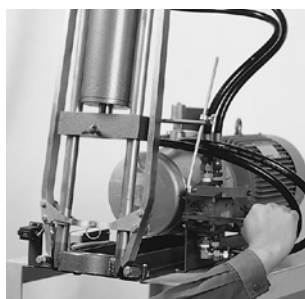

Push the operation lever to the back to lift up the pusher holder.

WARNING Do not let the pusher holder down before the die pusher is attached.

6 Attachment of pusher



Attach the pusher to the pusher holder. Fix the pusher by turning the screw of the pusher holder so that the pusher can freely rotate.

WARNING Only operate with the power off.

CAUTION The wrong choice of pusher will cause pullout of the hose, leakage, or damage.

7 Fixing die

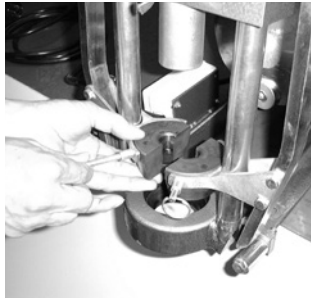

Attach the die onto the die fixing arm using the fixing pin.

- ⚠ WARNING**
Only operate with the power off.
- ⚠ CAUTION**
The wrong choice of pusher will cause pullout of the hose, leakage, or damage.

8 Application of lubricant

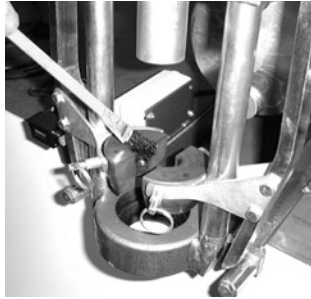

Apply lubricant to the inner surface of the die.

* Lubricant...
Steel coupling : Nihon Kosakuyu PG3740
Stainless coupling :
size 02-12 : JX Nippon Oil & Energy CFH68
size 16 : JX Nippon Oil & Energy DPX100

- ⚠ CAUTION**
If the recommended lubricant is not applied, coating damage and/or socket buckling may occur.

9 Insertion to pusher



Insert the coupling, to which the hose is inserted, into the pusher.

- ⚠ WARNING**
Use a hose of sufficient length to hold the hose.

10 Hose assembling (1)

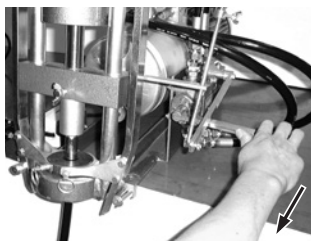

Hold the hose beneath the die base with your left hand.
Pushing the connector toward the pusher, pull the operation lever with your right hand to send the pusher down.
As the pusher comes down, adjust the positions of the die hole and the connector edge so they coincide.

- ⚠ DANGER** It is dangerous to hold the hose near the die base. The die could trap your hand.
- ⚠ DANGER** Never touch the moving parts when operating the tool.
- ⚠ CAUTION** Discrepancy of the positions of the die hole and the connector edge might cause damage to the coupling, such as socket defect.
- ⚠ CAUTION** When the die closes, check that the hose is not stuck in the die.

11 Hose assembling (2)

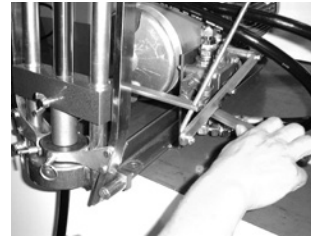

Pull the operation lever until the pusher touches the die.

- ⚠ CAUTION**
If you stop before the pusher touches the die, the swaging is insufficient and pullout of the hose or leakage may occur.

12 Hose assembling (3)

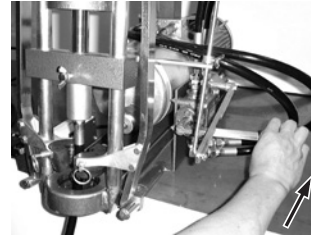

Push the operation lever to the back with your right hand to send the pusher up.
When the pusher goes up, the die opens by itself and the hose assembly can be removed.
(The valve stopper adjusts the upper position of the cylinder.)

- ⚠ CAUTION**
Pay strict attention to prevent the die from falling.

13 Completion of hose assembling

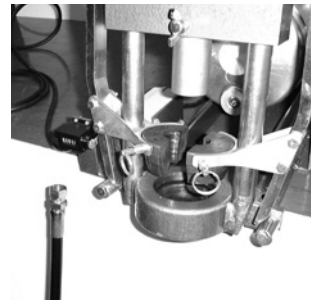

- ⚠ CAUTION**
Before putting the die in storage, remove dust from the inner surface and thinly grease it to prevent rust.

14 Check of hose assembly

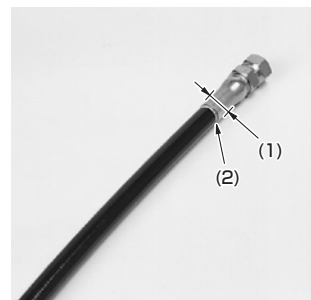

- (1) Check the swage diameter (see p.81).
- (2) Check the mark position of the hose insertion length.
- (3) Check the appearance of the coupling. (Check for any damage or misalignment of the track of the die.)
- (4) Check the appearance of the hose. (Check for any kink or cut.)

Should problems occur, do not use the hose assembly.

For details such as maintenance, please read the instruction manual that comes with the product.

Hydraulic Hose	Airless-painting Hose	Clean Hose	Adapter	Hose Guard Parts, Specially-Treated Parts	Assembling Machine, Jig, Tool	Hose Assembling Method	Technical Document	Reference Document
----------------	-----------------------	------------	---------	---	-------------------------------	------------------------	--------------------	--------------------

Hose assembly method

Swage coupling (applicable to both Mark 10 and Mark 9)

[Swage coupling] * For any couplings which are not introduced in the catalogue, please contact us.

A Coupling deduction length

The cutting length of a hose is obtained by the hose-coupling assembly length minus the coupling deduction length*.

* Coupling deduction length :
 A (SA coupling) and B (SE, SF coupling) in the figure.
 Ex. 3130-08 × 1000L SA-PT-08 × SE-PF-08
 If you wish to make a hose assembly using the above, cut the hose at the length of $1000 - (39 + 44) = 917$.

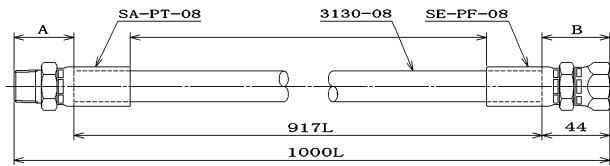

B Selection of pusher die

Part numbers are punched on pushers and dies.
 The wrong pusher or die will cause oil leakage or pullout of the hose, or disable hose assembling, so always check the number.

C Hose insertion length

Hose insertion lengths are presented in the list below.
 A shortage of hose insertion length will cause oil leakage or pullout of the hose. So mark the hose at the hose insertion length given in the list and insert the coupling into the hose to meet the marked position.

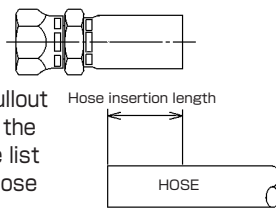

D Socket outer diameter after swaging

The socket outer diameter after swaging is measured at the point of about 10 mm from the socket end. Please regularly check the finished size. If the size is not appropriate, consult us to avoid possible oil leakage or pullout of the hose.

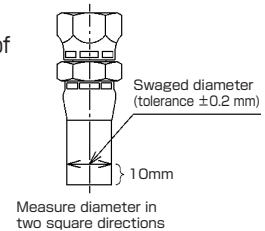

[Steel coupling]

Hose series	Hose size	Swage coupling part No.	A		B		C	D
			Coupling deduction length (mm)	Pusher part No.	Die part No.	Hose insertion length (mm)	Socket outer diameter after swaging (mm)	
LB70	02	SSA-PT-02	26.0	PSA-02	SPLB70-02	12	8.5±0.1	
		SSE-PF-02	30.0	PSE-02-001				
		SSF-PF-02						
LB70 · LF70	04	SA-PT-04-14	32.0	PSA-04	SP14-04-07	19	12.4±0.1	
		SE-PF-04-14	31.0	PSE-14-04				
		SF-PF-04-14						
LB70 · LF70	06	SA-PT-06-14	33.0	PSA-06	SP14-06-07	22	15.6±0.1	
		SE-PF-06-14	32.0	PSE-14-06				
		SF-PF-06-14						
LB70 · LF70	08	SA-PT-08-14	37.0	PSA-08	SP14-08	24	19.5±0.2	
		SE-PF-08-14	37.0	PSE-14-08				
		SF-PF-08-14						
LB70	10	SA-PT-10-N30	40.0	PSA-10	SP07-10	40	24.4±0.2	
		SE-PF-10-N30	44.0	PSE-10				
		SF-PF-10-N30						
LB70	12	SA-PT-12	43.0	PSA-12	SP3-12	40	28.1±0.2	
		SE-PF-12	47.0	PSE-12				
		SF-PF-12						
LB70	16	SA-PT-16	48.0	PSA-16	SP07-16	52	34.2±0.2	
		SE-PF-16	53.0	PSE-16				
		SF-PF-16						
1000 · 1100 · 1400	04	SA-PT-04-14	32.0	PSA-04	SP14-04	19	12.7±0.2	
		SE-PF-04-14	31.0	PSE-14-04				
		SF-PF-04-14						
	06	SA-PT-06-14	33.0	PSA-06	SP14-06	22	15.9±0.2	
		SE-PF-06-14	32.0	PSE-14-06				
		SF-PF-06-14						
1000	08	SA-PT-08-14	37.0	PSA-08	SP14-08	24	19.5±0.2	
		SE-PF-08-14	37.0	PSE-14-08				
		SF-PF-08-14						
1100	08	SA-PT-08-14	37.0	PSA-08	SP10-08	24	19.9±0.2	
		SE-PF-08-14	37.0	PSE-14-08				
		SF-PF-08-14						
1500	03	SA-PT-03-14	30.0	PSA-04	SP14-03	14.5	10.5±0.1	
		SE-PF-03-14	29.0	PSE-14-04				
		SF-PF-03-14						

Hose series	Hose size	Swage coupling part No.	A	B		C	D
			Coupling deduction length (mm)	Pusher part No.	Die part No.	Hose insertion length (mm)	Socket outer diameter after swaging (mm)
3130 · 34PW	02	SSA-PT-02	26.0	PSA-02	SP3-02-001	12	9.2±0.2
		SSE-PF-02	30.0	PSE-02-001			
		SSF-PF-02					
N3130 · 3700 3130 · 3000 · 34PW	03	SA-PT-03	32.0	PSA-04	SP3-03	26	12.4±0.2
		SE-PF-03	33.0	PSE-03			
		SF-PF-03					
	04	SA-PT-04	33.0	PSA-04	SP3-04	28	14.4±0.2
		SE-PF-04	36.0	PSE-04			
		SF-PF-04					
	05	SA-PT-05	35.0	PSA-06	SP3-05	28	16.0±0.2
		SE-PF-05	38.0	PSE-05			
		SF-PF-05					
	06	SA-PT-06	35.0	PSA-06	SP3-06	33	17.6±0.2
		SE-PF-06	39.0	PSE-06			
		SF-PF-06					
08	SA-PT-08	39.0	PSA-08	SP3-08	37	21.5±0.2	
	SE-PF-08	44.0	PSE-08				
	SF-PF-08						
N3130 · 3700 3130 · 3000	12	SA-PT-12	43.0	PSA-12	SP3-12	40	28.1±0.2
		SE-PF-12	47.0	PSE-12			
		SF-PF-12					
	16	SA-PT-16	48.0	PSA-16	SP3-16	52	34.5±0.2
		SE-PF-16	53.0	PSE-16			
		SF-PF-16					
N3000 · HT	04	SA-PT-04	33.0	PSA-04	SPN-04	28	14.6±0.2
		SE-PF-04	36.0	PSE-04			
		SF-PF-04					
	06	SA-PT-06-N30	35.0	PSA-06	SPN-06	33	18.9±0.2
		SE-PF-06-N30	39.0	PSE-06			
		SF-PF-06-N30					
	08	SA-PT-08-N30	39.0	PSA-08	SPN-08	37	22.7±0.2
		SE-PF-08-N30	44.0	PSE-08			
		SF-PF-08-N30					
	10	SA-PT-10-N30	40.0	PSA-10	SPN-10	40	26.2±0.2
		SE-PF-10-N30	44.0	PSE-10			
		SF-PF-10-N30					
3R80	03	SA-PT-03-3R	35.0	PSA-04	SPH-03	23	13.5±0.2
		SE-PF-03-3R	36.0	PSE-03			
		SF-PF-03-3R					
	04	SA-PT-04-3R	33.0	PSA-04	SPH-04	28	17.2±0.2
		SE-PF-04-3R	36.0	PSE-04			
		SF-PF-04-3R					
	06	SA-PT-06-N30	35.0	PSA-06	SPH-06	33	20.1±0.2
		SE-PF-06-N30	39.0	PSE-06			
		SF-PF-06-N30					
	08	SA-PT-08-N30	39.0	PSA-08	SPH-08	37	23.0±0.2
		SE-PF-08-N30	44.0	PSE-08			
		SF-PF-08-N30					
3R80 · 34PW	12	SA-PT-12-3R	43.0	PSA-12	SPH-12	40	29.5±0.2
		SE-PF-12-3R	47.0	PSE-12			
		SF-PF-12-3R					
	16	SA-PT-16-3R	48.0	PSA-16	SPH-16	52	37.8±0.2
		SE-PF-16-3R	53.0	PSE-16			
		SF-PF-16-3R					

Hydraulic hose products	Hydraulic Hose
	Airless-painting Hose
	Clean Hose
Adapter	Adapter
	Hose Guard Parts, Specially-Treated Parts
Assembling Machine, Jig, Tool	Assembling Machine, Jig, Tool
	Hose Assembling Method
Technical Document	Technical Document
Reference Document	Reference Document

Hose assembly method

Swage coupling (applicable to both Mark 10 and Mark 9)

[Swage coupling] * For any couplings which are not introduced in the catalogue, please contact us.

A Coupling deduction length

The cutting length of a hose is obtained by the hose-coupling assembly length minus the coupling deduction length*.

* Coupling deduction length :
 A (SA coupling) and B (SE, SF coupling) in the figure.
 Ex. 3130-08 × 1000L SA-PT-08 × SE-PF-08
 If you wish to make a hose assembly using the above, cut the hose at the length of $1000 - (39 + 44) = 917$.

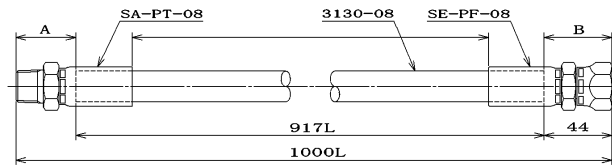

B Selection of pusher die

Part numbers are punched on pushers and dies.
 The wrong pusher or die will cause oil leakage or pullout of the hose, or disable hose assembling, so always check the number.

C Hose insertion length

Hose insertion lengths are presented in the list below.
 A shortage of hose insertion length will cause oil leakage or pullout of the hose. So mark the hose at the hose insertion length given in the list and insert the coupling into the hose to meet the marked position.

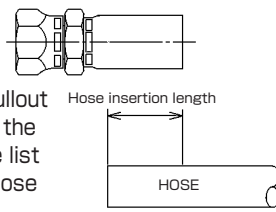

D Socket outer diameter after swaging

The socket outer diameter after swaging is measured at the point of about 10 mm from the socket end.
 Please regularly check the finished size. If the size is not appropriate, consult us to avoid possible oil leakage or pullout of the hose.

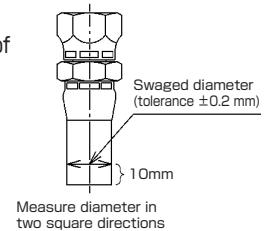

[Stainless steel coupling]

Hose series	Hose size	Swage coupling part No.	A Coupling deduction length (mm)	Pusher part No.	B Die part No.		C Hose insertion length (mm)	D Socket outer diameter after swaging (mm)		
					First	Second				
1000 · 1100 · 1400	04	SA-PT-04-14-S	32.0	PSA-04	SPH-03	SP14-04	19	12.7±0.2		
		SE-PF-04-14-S	31.0	PSE-14-04						
		SF-PF-04-14-S	31.0	PSE-14-04						
	06	SA-PT-06-14-S	33.0	PSA-06	SP3-05-1-ST	SP14-06				
		SE-PF-06-14-S	32.0	PSE-14-06						
		SF-PF-06-14-S	32.0	PSE-14-06						
1000	08	SA-PT-08-14-S	37.0	PSA-08	SPH-06-1-ST	SP14-08	24	19.5±0.2		
		SE-PF-08-14-S	37.0	PSE-14-08						
		SF-PF-08-14-S	37.0	PSE-14-08						
1100	08	SA-PT-08-14-S	37.0	PSA-08	SPH-06-1-ST	SP10-08				
		SE-PF-08-14-S	37.0	PSE-14-08						
		SF-PF-08-14-S	37.0	PSE-14-08						
3130 · 34PW	02	SSA-PT-02-S	26.0	PSA-02	SP3-02-001	—	12	9.2±0.2		
		SSE-PF-02-S	30.0	PSE-02-001						
		SSF-PF-02-S	30.0	PSE-02-001						
N3130 · 3700 3130 · 3000	03	SA-PT-03-S	32.0	PSA-04	SP3-03-1-ST	SP3-03			24	12.4±0.2
		SE-PF-03-S	33.0	PSE-03						
N3130 · 3700	04	SA-PT-04-S	33.0	PSA-04	SP3-04-1-ST	KM-04				
		SE-PF-04-S	36.0	PSE-04						
		SF-PF-04-S	36.0	PSE-04						
3130 · 3000 · 34PW	04	SA-PT-04-S	33.0	PSA-04	SP3-04-1-ST	SP3-04	28	14.4±0.2		
		SE-PF-04-S	36.0	PSE-04						
		SF-PF-04-S	36.0	PSE-04						
N3130 · 3700 3130 · 3000 · 34PW	06	SA-PT-06-S	35.0	PSA-06	SP3-06-1-ST	SP3-06				
		SE-PF-06-S	39.0	PSE-06						
		SF-PF-06-S	39.0	PSE-06						
	08	SA-PT-08-S	39.0	PSA-08	SP3-08-1-ST	SP3-08	37	21.5±0.2		
		SE-PF-08-S	44.0	PSE-08						
		SF-PF-08-S	44.0	PSE-08						
N3130 · 3700 3130 · 3000	12	SA-PT-12-S	43.0	PSA-12	SP3-12-1-ST	SP3-12			40	28.1±0.2
		SE-PF-12-S	47.0	PSE-12						
		SF-PF-12-S	47.0	PSE-12						
	16	SA-PT-16-S	48.0	PSA-16	SP3-16-1-ST	SP3-16				
		SE-PF-16-S	53.0	PSE-16						
		SF-PF-16-S	53.0	PSE-16						

Hose series	Hose size	Swage coupling part No.	A		B		C	D
			Coupling deduction length (mm)	Pusher part No.	Die part No.		Hose insertion length (mm)	Socket outer diameter after swaging (mm)
					First	Second		
N3000 · HT	04	SA-PT-04-S	33	PSA-04	SP3-04-1-ST	SPN-04	28	14.6±0.2
		SE-PF-04-S	35	PSE-04				
	06	SA-PT-06-N30-S	34	PSA-06	SPH-06-1-ST	SPN-06	33	18.9±0.2
		SE-PF-06-N30-S	38	PSE-06				
	08	SA-PT-08-N30-S	39	PSA-08	SPH-08-1-ST	SPN-08	37	22.7±0.2
		SE-PF-08-N30-S	43	PSE-08				
3R80	04	SA-PT-04-3R-S	33	PSA-04	SPH-04-1-ST	SPH-04	28	17.2±0.2
		SE-PF-04-3R-S	35	PSE-04				
	06	SA-PT-06-N30-S	34	PSA-06	SPH-06-1-ST	SPH-06	33	20.1±0.2
		SE-PF-06-N30-S	38	PSE-06				
	08	SA-PT-08-N30-S	39	PSA-08	SPH-08-1-ST	SPH-08	37	23.0±0.2
		SE-PF-08-N30-S	43	PSE-08				
3R80 · 34PW	12	SE-PF-12-3R-S	47	PSE-12	SPH-12-1-ST	SPH-12	40	29.5±0.2
	16	SE-PF-16-3R-S	53	PSE-16	SPH-16-1-ST	SPH-16	52	37.8±0.2
34PW	04	SE-G-04-PW	36	PSE-04	SP3-04-VC	—	28	14.4±0.2
	06	SE-G-06-PW	39	PSE-06	SP3-06-VC	—	33	17.6±0.2
	08	SE-G-08-PW	44	PSE-08	SP3-08-VC	—	37	21.5±0.2
	12	SE-G-12-PW	47	PSE-12	SPH-12-1-ST	SPH-12-VC	40	29.5±0.2
	16	SE-G-16-PW	53	PSE-16	SPH-16-1-ST	SPH-16-37VC	52	37.0±0.2
	04	SE-G-04-PWL	31	PSE-04-PWL	SPP-04-VC	—	11	14.7±0.2
	06	SE-G-06-PWL	32	PSE-06-PWL	SPP-06-VC	—	11	18.0±0.2
	08	SE-G-08-PWL	39	PSE-08-PWL	SPP-08-VC	—	14	21.8±0.2
	12	SE-G-12-PWL	42	PSE-12-PWL	SPP-12-VC	—	21	29.6±0.2
	16	SE-G-16-PWL	45	PSE-16-PWL	SPP-16-VC	—	29	37.2±0.2

Hydraulic hose products

- Hydraulic Hose
- Airless-painting Hose
- Clean Hose
- Adapter
- Hose Guard Parts, Specially-Treated Parts
- Assembling Machine, Jig, Tool
- Hose Assembling Method
- Technical Document
- Reference Document

Hose assembly method

Reusable coupling

Assembling method

1 Preparation

Prepare appropriate hose, coupling, hose cutter, holding die, lubricant*, adjustable wrench, scale, and white pen.



* lubricant...
Steel coupling : Nihon Kosakuyu PG3740
Stainless coupling :
size 02-12 : JX Nippon Oil & Energy CFH68
size 16 : JX Nippon Oil & Energy DPX100

CAUTION

If the recommended lubricant is not applied, coating damage and/or socket buckling may occur.

2 Hose cutting

Determine the cutting length of the hose based on the hose assembling length and cut the hose squarely using the special hose cutter.



WARNING Do not touch the blade of the cutter.

CAUTION The slanted cut section may cause pullout of the hose and leakage.

CAUTION If the blade is blunt, correct assembly is not possible. Change the hose cutter in this case.

3 Marking the insertion length of the hose

Measure the insertion length of the hose with a scale and mark the hose at the insertion length with the white pen.



It is recommended to draw a marking line with a width of about 2 mm in order to check it after swaging.

4 Disassembling of coupling

Disassemble the reusable coupling into socket and nipple.

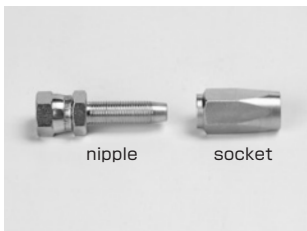

nipple socket

5 Preparation to insert coupling

Nip the hose with the holding die, leaving the length of hose end to be inserted into the socket, and fix it in the vice. For easy screwing, apply lubricant to the surface of the hose end.



6 Insertion of socket

Insert the socket into the hose end and tighten it anti-clockwise with your hand. Then use the adjustable wrench to screw the socket to the position marked on the hose. Check that there is about a 2-3 mm space between the inner end of the socket and the hose end.



CAUTION

Stop screwing before the inner end of the socket reaches the hose end, otherwise damage to the core tube will occur and cause leakage.

7 Insertion of the nipple (1)

Remove the assembly from the vice and the holding die. Nip the socket with the vice and apply lubricant to the nipple thread and the inner surface of the hose.



8 Insertion of the nipple (2)

Tighten the nipple clockwise with your hand and use an appropriate adjustable wrench to slowly screw the nipple until its hexagonal part touches the socket.



CAUTION

Do not screw further, once the nipple touches the socket. It may cause damage to the coupling.

CAUTION

Using a machine to quickly screw the nipple may cause damage to the core tube or the coupling, leading to pullout of the hose or leakage.

9 Completion of hose assembling

After finishing the tightening of the nipples, check for deformation of the core tube by inserting a checking stick into the coupling.



10 Check of hose assembly

- (1) Check the mark position of the hose insertion length.
 - (2) Check the appearance of the coupling. (Check for any damage.)
 - (3) Check the appearance of the hose. (Check for any kink or cut.)
- Should problems occur, do not use the hose assembly.



For details such as maintenance, please read the instruction manual that comes with the product.

[Reusable coupling] * For any couplings which are not introduced in the catalogue, please contact us.

A Coupling deduction length

The cutting length of a hose is obtained by the hose-coupling assembly length minus the coupling deduction length*.

* Coupling deduction length :

A (SA coupling) and B (SE, SF coupling) in the figure.

Ex. 3130-08 × 1000L SA-PT-08 × E-PF-08
If you wish to make a hose assembly using the above,
cut the hose at the length of $1000 - (43 + 46) = 911$.

E-PF-08
A-PT-08

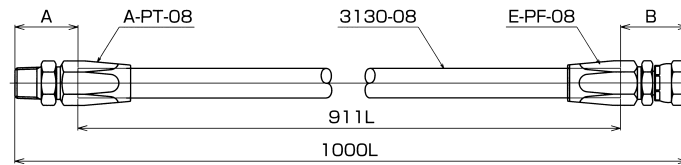

B Hose insertion length

Hose insertion lengths are presented in the list below.

A shortage of hose insertion length will cause oil leakage or pullout of the hose. So mark the hose at the hose insertion length given in the list and insert the coupling into the hose to meet the marked position.

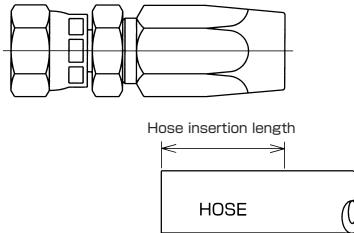

Table of hose screwing length

Hose series	Hose size	Reusable coupling part No.	A	B
			Coupling deduction length (mm)	Hose insertion length (mm)
3130	02	A-PT-02	25.5	16
		E-PF-02	31.5	
		F-PF-02		
3130 · 3000	03	A-PT-03	30.0	21
		E-PF-03	32.5	
		F-PF-03		
	04	A-PT-04	31.5	25
		E-PF-04	34.0	
		F-PF-04		
3130	05	A-PT-05	35.5	29
		E-PF-05	37.0	
		F-PF-05		
3130 · 3000	06	A-PT-06	37.5	30
		E-PF-06	40.0	
		F-PF-06		
	08	A-PT-08	43.0	36
		E-PF-08	46.0	
		F-PF-08		
	12	A-PT-12	46.5	38
		E-PF-12	47.5	
		F-PF-12		
3000	16	A-PT-16	49.5	42
		E-PF-16	50.0	
		F-PF-16		

Hydraulic hose products

- Hydraulic Hose
- Airless-painting Hose
- Clean Hose
- Adapter
- Hose Guard Parts, Specially-Treated Parts
- Assembling Machine, Jig, Tool
- Hose Assembling Method
- Technical Document
- Reference Document

Technical data

How to select a hose

How to read the catalog

N3130

Features

- Flexible and tough
- JIS K 6375 A certificated, SAE100R7 certificated

Nonconductive hose with high electrical insulation is also available.

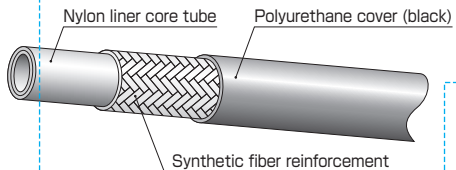

Part No.	Size			Max. working pressure		Min. burst pressure		Min. bending radius (mm)	Weight (g/m)	Coupling
	Size No.	I.D. (in.) (mm)	O.D. (mm)	(MPa)	(PSI)	(MPa)	(PSI)			
N3130-03	03	3/16	4.8	10.4	21.0	3,000	84.0	12,000	20	65
N3130-04	04	1/4	6.4	12.7	19.5	2,850	77.0	11,200	40	105
N3130-05	05	5/16	8.1	14.7	17.5	2,550	70.0	10,200	45	130
N3130-06	06	3/8	9.8	16.4	16.0	2,300	63.0	9,100	50	150
N3130-08	08	1/2	12.8	20.3	14.0	2,000	56.0	8,000	75	210
N3130-12	12	3/4	19.2	26.6	9.0	1,300	35.0	5,100	130	290
N3130-16	16	1	25.7	33.4	7.0	1,000	28.0	4,000	165	400

■ Appropriate fluid : mineral general operating oil
 ■ Working temperature range : -40 to +100°C
 ■ Length in a unit package : 100m for sizes 03, 04, 05, 06, 08, and 50m for sizes 12, 16

1 Size (inner diameter)

It is necessary to select the correct hose size (inner diameter) to obtain the necessary flow volume. In general, the flow speed range shown below is the standard.

Too small an inner diameter of hose and coupling leads to an increase of flow speed, which causes problems such as pressure loss and increase of oil temperature. Pressure loss may vary with fluid viscosity,

flow volume, and circuit length.

To see how flow speed, inner diameter, and flow volume, relate to each other, refer to [nomograph] on P.72

Pump intake and return line	0.5~1.5m/sec
Pressurization line	2.0~8.0m/sec

2 Pressure

Fluid pressure in hydraulic circuits varies, e.g. negative pressure, static fluid, or impact pressure. The maximum working pressure (regular pressure) of the hose represents the maximum pressure for continuous use, and is generally set according to the relief set pressure.

Furthermore, an impact pressure may occur in the oil-hydraulic circuit in concurrence with the opening or closing of the circuit.

In general, the waveform of impact pressure can be a peak wave type (maximum working pressure × 150%) or trapezoidal waveform (maximum working pressure × 125% or × 133%).

Please consult us if the negative pressure is large, although a resin has a higher rigidity than rubber in general regarding negative pressure and there should be no problem as long as the negative pressure is small.

③ Bending radius

The hose can be bent, but there is always a limit. If the hose is bent at a radius smaller than the minimum bending radius, deformation or kink of the hose may occur and cause problems.

Please bend the hose at a radius larger than the minimum bending radius.

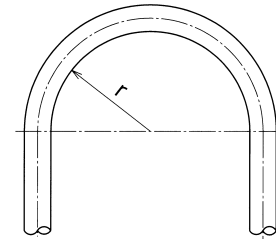

r : Bending radius

④ Coupling

The coupling consists of a connection to equipment, a hexagonal part, and a connection to the hose. There are various types of couplings, including adapters. Sometimes connections to the imported equipment do not work well

because their thread and sheet shape differs from the JIS standard. Therefore, check the thread type, sealing method and sheet surface shape and angle of equipment to be connected before selecting couplings.

⑤ Electrical insulation [nonconductive hose]

Plastic hoses in general have high electrical insulation. When electrical insulation is particularly necessary, e.g. for the hydraulic hose of electrical work equipment, leakage current is sometimes determined. Contact us in this case.

When electrical insulation is required, a nonconductive hose without pin pricking (no pin hole for gas venting) is also available to prevent the reduction of electrical insulation due to external water invasion.

⑥ Fluid type

Since the hose core tube is made of high oil resistant plastic, it will not be damaged by mineral or aqueous hydraulic oil. However, some types of synthetic hydraulic oil and nonflammable special oil could affect the hose.

Typical couplings and adapters are made of zinc galvanized

steel. Contact us if using a special fluid that may damage the material or the surface processing.

 Stainless couplings or black colored couplings (made-to-order) are also available if using water or glycol hydraulic oil.

⑦ Working temperature (fluid temperature, atmospheric temperature)

Using a hose at a temperature higher than the specification may cause thermal degradation and could shorten the hose life. Also using at a temperature lower than the specification could make the hose harder and

frangible. When effects of atmospheric temperature, e.g. radiational heat, are expected, use a heat insulator to protect the hose.

Technical data

How to determine the hose length

Fixed piping

Since the length of the hose may change by +3% when pressurized, give some extra length to the hose to prevent shrinkage stress. Also since the minimum bending radius is determined for the specification of each hose, follow the

standard and keep the hose straight (for about the same length as the outer diameter of the hose) near the coupling edge to prevent sharp bending.

Formula when using the hose in a straight line

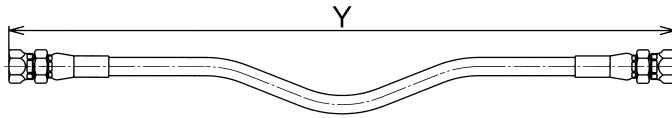

$$L = Y \times 1.03$$

L : Length of hose assembly
Y : Working straight length

Formula when using the hose in a U-line

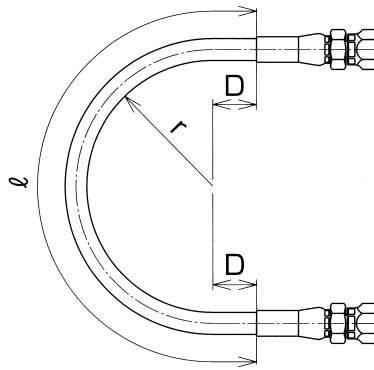

$$\ell = \pi(r + D/2) + 2D$$

ℓ : Free length of hose
π : Ludolphian number
r : Minimum bending radius of hose
D : Maximum outer diameter of hose

Movable piping

For movable hose, determine the hose length with attention paid to the hose movement to prevent sharp bending or kink near the coupling edge.

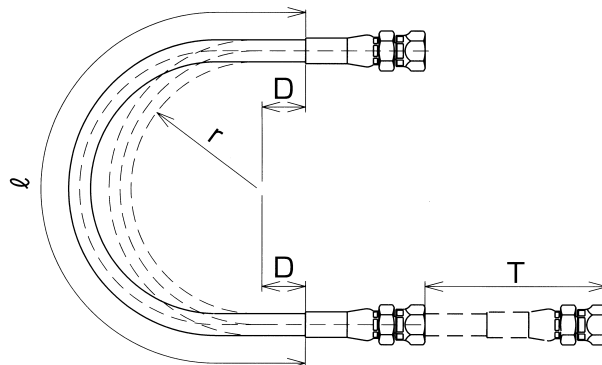

$$\ell = \pi(r + D/2) + 2D + T$$

ℓ : Free length of hose
π : Ludolphian number
r : Minimum bending radius of hose
D : Maximum outer diameter of hose
T : Stroke

How to select the hose size for given flow volume and velocity

Explanation of nomograph

The figure below is to help in the selection of the most suitable choice of hose for equipment. Keep the flow velocity in the column. If the flow velocity exceeds the recommended value, problems such as increased pressure loss and overheating could occur. Generally, when fluid flows in a hose, the "flow volume", "flow velocity", and "hose cross section" are linked as shown in the formula below.

$$\text{Hose cross section (cm}^2\text{)} = \frac{\text{Flow volume (} \ell\text{/min)}}{\text{Flow velocity (m/sec)} \times 60} \times 10$$

Therefore, if any two of the three are given, the rest is determined by this formula.

How to use the graph

- 1) Select the discharge flow volume of the pressure line in the leftmost line graph.
- 2) Select the flow velocity in the recommended range of the rightmost line graph.
- 3) Draw a line connecting both points obtained above and find the correct hose inner diameter at the point where the line crosses the central graph.

Nomograph

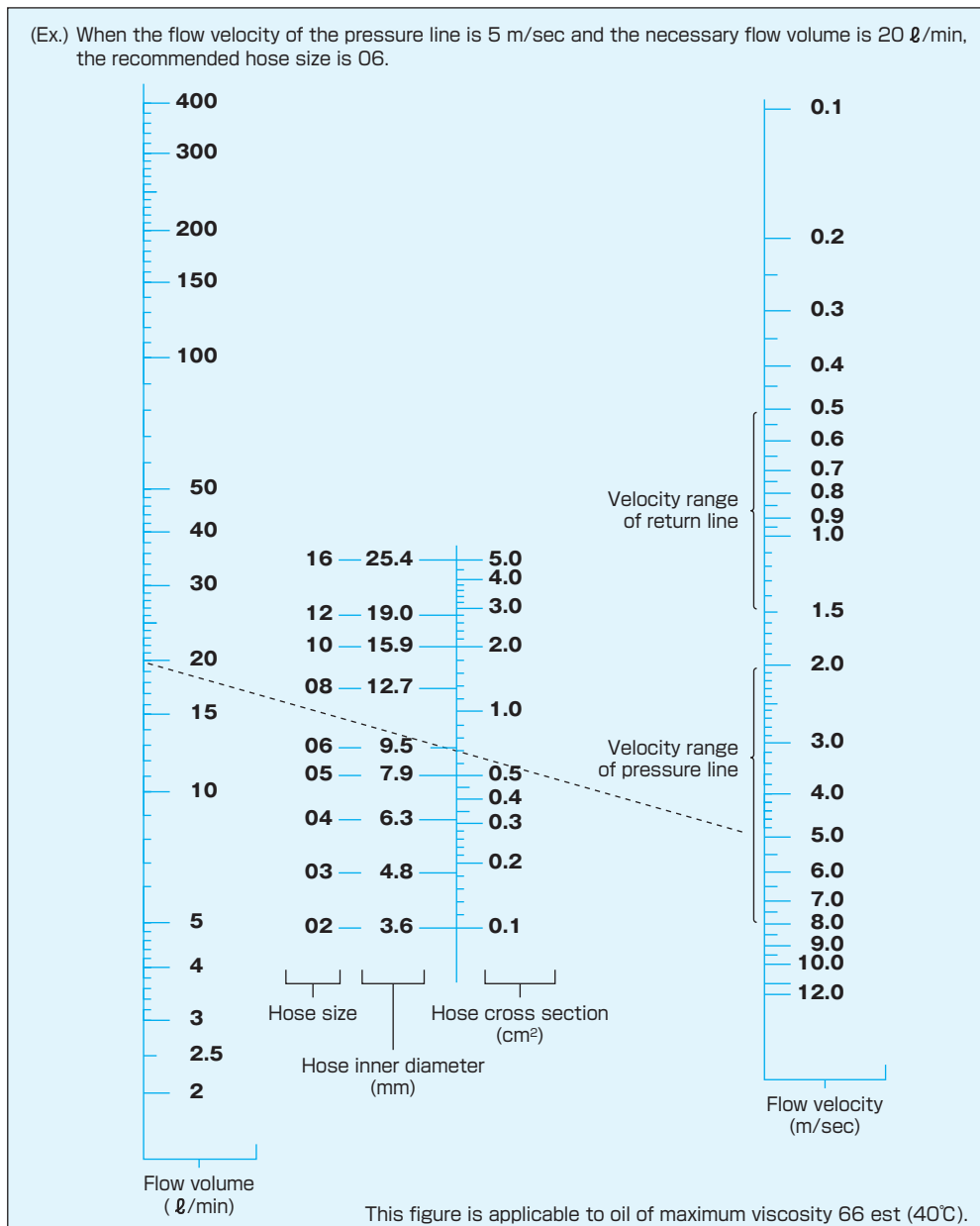

- Hydraulic Hose
- Airless-painting Hose
- Clean Hose
- Adapter
- Hose Guard Parts, Specially-Treated Parts
- Assembling Machine, Jig, Tool
- Hose Assembling Method
- Technical Document
- Reference Document

Graphs for cubical expansion of hoses

How to use the graph

1. • represents the maximum working pressure
 2. The hose size indicates inner diamete
- 📞 Please contact us for the details of 35NG series.

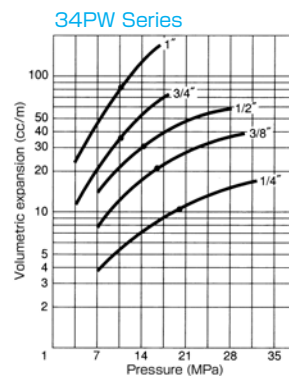
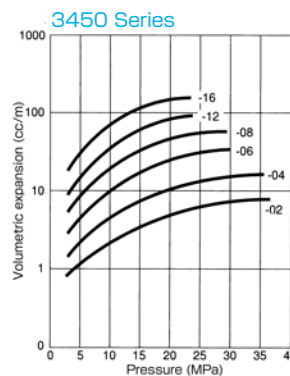
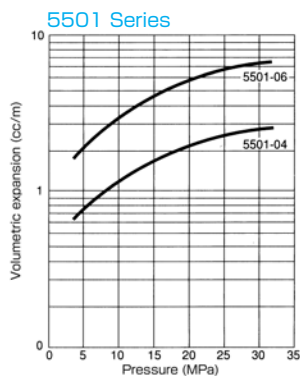
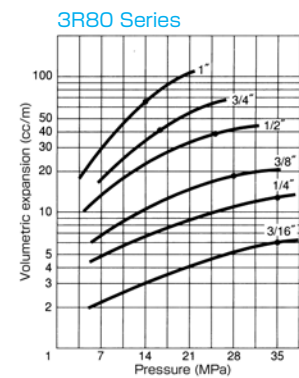
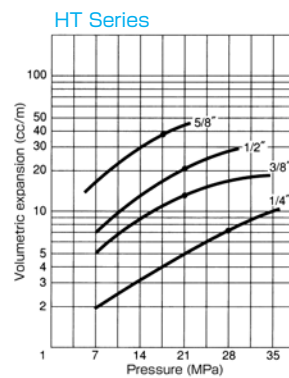
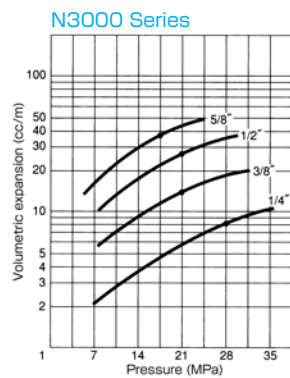
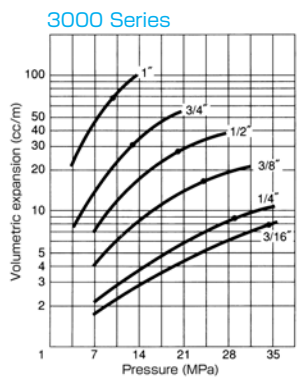
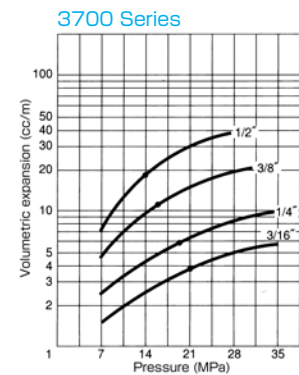
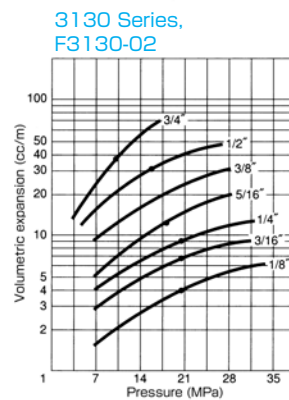
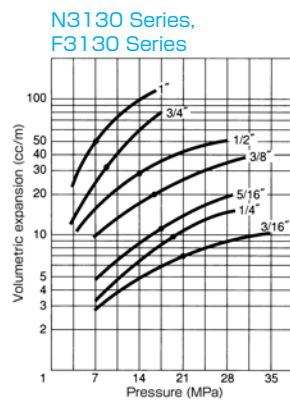
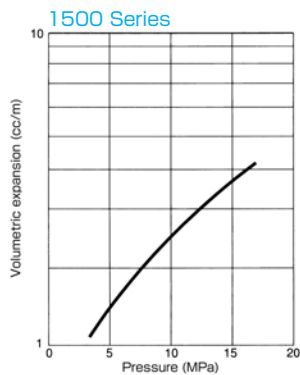
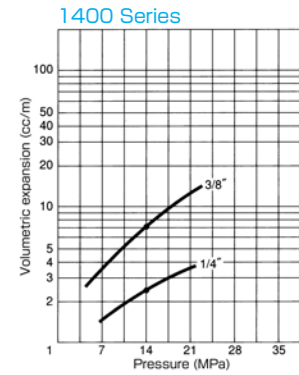
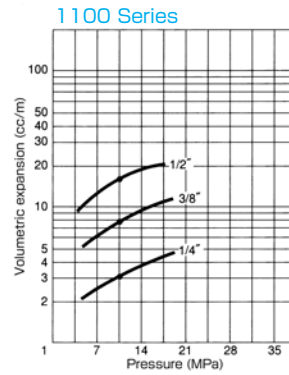
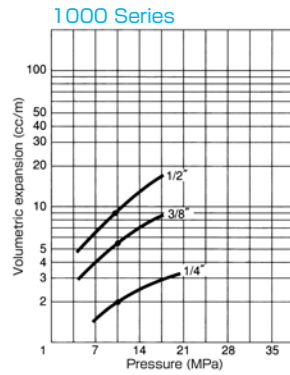
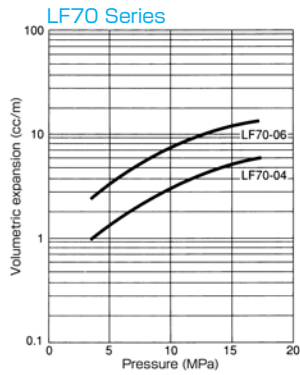

Tightening torque of hose couplings and adapters

(Parallel pipe thread)

Thread size	1/8	1/4	3/8	1/2	3/4	1
G (PF) Thread	15N · m	25N · m	34N · m	64N · m	132N · m	196N · m

(Taper pipe thread)

Thread size	1/8	1/4	3/8	1/2	3/4	1
R (PT) Thread	10 to 15N · m	25 to 30N · m	45 to 50N · m	60 to 70N · m	120 to 140N · m	140 to 160N · m

(Unified fine thread)

Thread size	7/16-20	1/2-20	9/16-18	3/4-16	7/8-14
UNF Thread	25N · m	30N · m	40N · m	50N · m	60N · m

(American Standard straight pipe threads for free-fitting mechanical joints for fixtures)

Thread size	1/4	3/8
NPSM Thread	25N · m	34N · m

(Shape and size of JIS-standard O-ring port (JISB2351))

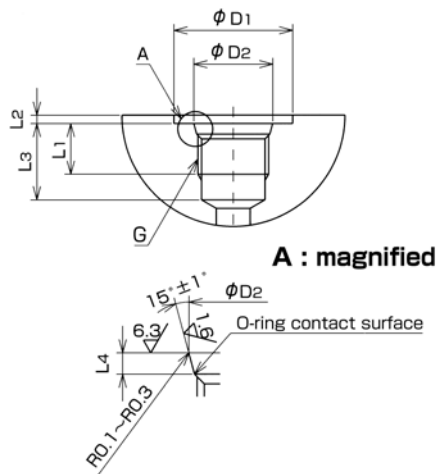

Thread name G	$D_1 \pm 0.3$	$D_1^{+0.1}_0$	L_1 (Min)	L_2 (Max)	L_3 (Min)	$L_4^{+0.40}_0$	Suitable O-ring number
1/8	18	11.6	10	1.0	15	2.0	P8
1/4	24	15.6	12	1.5	18	2.5	P11
3/8	28	18.6	12	2.0	18	2.5	P14
1/2	34	22.6	16	2.5	24	2.5	P18
3/4	45	29.8	17	2.5	25	3.5	P24
1	51	35.8	21	2.5	30	3.5	P29

- There must be no axial scratch or spiral tool mark on the O-shaped O-ring contact surface.
- D_1 scraped surface must be squarely or flat to the thread axis.

Connection method of hose coupling (with sheet) and adapter

1 Coupling

Tighten with your hand until the two sheets perfectly contact each other.

CAUTION Adjust the axes of the coupling and adapter to prevent non-uniform contact of sheets. After tightening with your hand, please check for any unwanted space between the coupling and adapter.

2 Fixing

Fix the adapter and nipple with a spanner so that the sheets cannot rotate together, and tighten the nut with a torque wrench (see the figure). When the rotation speed of the torque wrench is high, the surface pressure at the sheet surface is low, which might cause leakage. In this case, slowly tighten again until you feel a click.

CAUTION The tightening torque should follow the figures in the "parallel pipe thread" table on the previous page. If the sheets are rotated while contacting each other, it will damage the sheet surface and cause leakage.

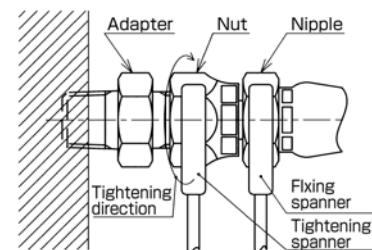

Reference

Technical standard for threads

Types

Thread symbol	Thread type	Related standard
G (PF)	Parallel pipe thread	JIS B0202
R (PT)	Taper pipe thread	JIS B0203
UNC	Unified coarse thread	JIS B0206
UNF	Unified fine thread	JIS B0208
M	Metric coarse thread	JIS B0205
M	Metric fine thread	JIS B0207
NPT	American Standard taper pipe threads for general use	ANSI B1 / 20 / 1
NPS	American Standard straight threads	ANSI B1 / 20 / 1
NPTF	Dryseal American Standard taper pipe threads	ANSI B1 / 20 / 3
NPSM	American Standard straight pipe threads for free-fitting mechanical joints for fixtures	ANSI B1 / 20 / 1

Class

Thread type	Parallel male pipe thread		Unified thread						Metric thread	
	Class A	Class B	Class 3A	Class 3B	Class 2A	Class 2B	Class 1A	Class 1B	Female thread	Male thread
Class	Class A	Class B	Class 3A	Class 3B	Class 2A	Class 2B	Class 1A	Class 1B	4H~6H	6~8g
Notation	A	B	3A	3B	2A	2B	1A	1B	4H~6H	6~8g

Expressional example

G 3/4-B

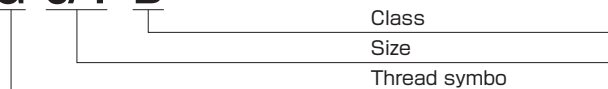

9/16-18 UNF-2B



M 18×1.5-2

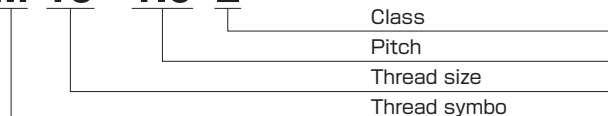

(Parallel pipe thread) [JIS B0202]

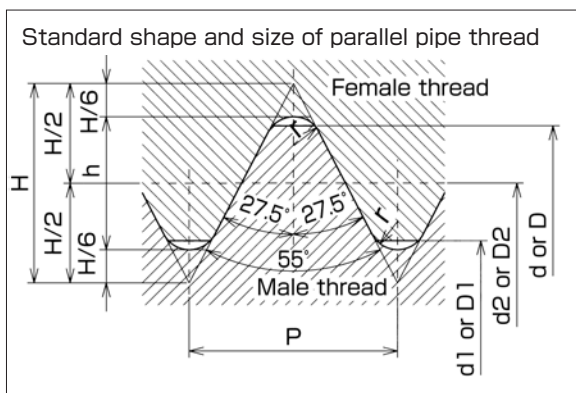

Thread name	Number of screw threads (per 25.4 mm)	Pitch P (reference)	Height of thread h	Curvature of top	Male thread		
					Outer diameter d	Pitch diameter d_2	Root diameter d_1
					Female thread		
					Outer diameter d	Pitch diameter d_2	Root diameter d_1
G1/8	28	0.9071	0.581	0.12	9.728	9.147	8.566
G1/4	19	1.3368	0.856	0.18	13.157	12.301	11.445
G3/8	19	1.3368	0.856	0.18	16.662	15.806	14.950
G1/2	14	1.8143	1.162	0.25	20.955	19.793	18.631
G3/4	14	1.8143	1.162	0.25	26.441	25.279	24.117
G1	11	2.3091	1.479	0.32	33.249	31.770	30.291

[Taper pipe threads] [JIS B0203]

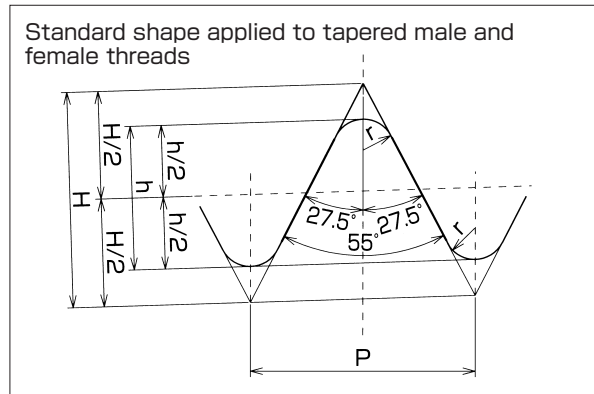

Thread name (PT)	Thread				Standard diameter			Position of standard diameter		Tolerance of D_1, D_2 and D_1 of female thread	Length of useful thread				Size of carbon-steel pipe (reference)		
	Number of screw threads (per 25.4 mm) n	Pitch P (reference)	Height of thread h	Curvature radius r or r_2	Male thread			Female thread			From position of standard diameter to larger diameter part						
					Outer diameter d	Pitch diameter d_2	Root diameter d_1	Male thread	Female thread		With incomplete thread part		Without incomplete thread part				
					Root diameter D	Pitch diameter D_2	Inner diameter D_1	From pipe edge	At pipe edge		Taper female thread	Parallel male thread	Taper female thread, parallel female thread	Outer diameter	Thickness		
R1/8	28	0.9701	0.581	0.12	9.728	9.147	8.566	3.97	± 0.91	± 1.13	± 0.071	2.5	6.2	7.4	4.4	10.5	2.0
R1/4	19	1.3368	0.856	0.18	13.157	12.301	11.445	6.01	± 1.34	± 1.67	± 0.104	3.7	9.4	11.0	6.7	13.8	2.3
R3/8	19	1.3368	0.856	0.18	16.662	15.806	14.950	6.35	± 1.34	± 1.67	± 0.104	3.7	9.7	11.4	7.0	17.3	2.3
R1/2	14	1.8143	1.162	0.25	20.955	19.793	18.631	8.16	± 1.81	± 2.27	± 0.142	5.0	12.7	15.0	9.1	21.7	2.8
R3/4	14	1.8143	1.162	0.25	26.441	25.279	24.117	9.53	± 1.81	± 2.27	± 0.142	5.0	14.1	16.3	10.2	27.2	2.8
R1	11	2.3091	1.479	0.32	33.249	31.770	30.291	10.39	± 2.31	± 2.89	± 0.181	6.4	16.2	19.1	11.6	34.0	3.2

[Unified fine thread] [JIS B0208]

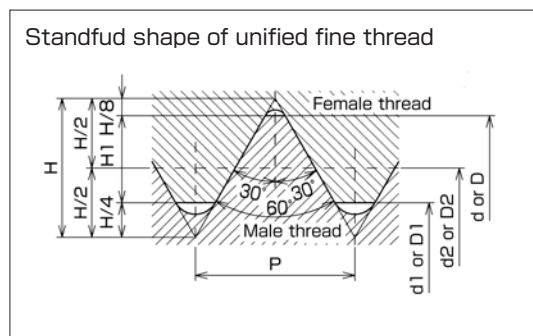

Thread name	Number of screw threads (per 25.4 mm) n	Pitch P (reference)	Height of engagement H_1	Male thread		
				Outer diameter d	Pitch diameter d_2	Root diameter d_1
				Female thread		
				Root diameter D	Pitch diameter D_2	Inner diameter D_1
1/4 -28 UNF	28	0.9071	0.491	6.350	5.761	5.367
5/16-24 UNF	24	1.0583	0.573	7.938	7.249	6.792
3/8 -24 UNF	24	1.0583	0.573	9.525	8.837	8.379
7/16-20 UNF	20	1.2700	0.687	11.112	10.287	9.738
1/2 -20 UNF	20	1.2700	0.687	12.700	11.874	11.326
9/16-18 UNF	18	1.4111	0.764	14.288	13.371	12.761
5/8 -18 UNF	18	1.4111	0.764	15.875	14.958	14.348
3/4 -16 UNF	16	1.5875	0.859	19.050	18.019	17.330
7/8 -14 UNF	14	1.8143	0.982	22.225	21.046	20.262

[Metric fine thread] [JIS B0207]

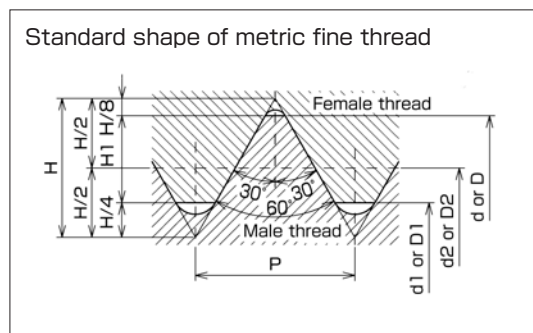

Thread name	Pitch P (reference)	Height of engagement H_1	Male thread		
			Outer diameter d	Pitch diameter d_2	Root diameter d_1
			Female thread		
			Root diameter D	Pitch diameter D_2	Inner diameter D_1
M12×1.5	1.5	0.812	12.000	11.026	10.376
M14×1.5	1.5	0.812	14.000	13.026	12.376
M16×1.5	1.5	0.812	16.000	15.026	14.376
M18×1.5	1.5	0.812	18.000	17.026	16.376
M20×1.5	1.5	0.812	20.000	19.026	18.376
M22×1.5	1.5	0.812	22.000	21.026	20.376
M24×1.5	1.5	0.812	24.000	23.026	22.376
M30×1.5	1.5	0.812	30.000	29.026	28.376

Technical standard for plastic hoses

Standard Item	Japan		ISO		USA		
	JIS K 6375 (Hose) JIS B 8362 (Hose assembly)		ISO 3949		SAE J 517		
Type	Type 1	Type 2	Type 1	Type 2	100R7	100R8	
Main performance	Maximum working pressure	Minimum burst pressure × 1/4	←	←	←	←	
	Test pressure	Maximum working pressure × 2	←	←	←	←	
	Minimum burst pressure	Maximum working pressure × 4	←	←	←	←	
	Working temperature range	-40°C to +100°C	←	←	←	-40°C to +93°C	
	Fatigue resistance	Pressure	Maximum working pressure × 125%	Maximum working pressure × 133%	Maximum working pressure × 125%	Maximum working pressure × 133%	Maximum working pressure × 125%
		Waveform	Square	←	←	←	←
		Frequency	150,000	200,000	150,000	200,000	150,000
		Oil temperature	93°C	←	←	←	←
		Cycle	30 to 75 cycle/min	←	←	←	←
		Oil type	Two types of JIS K2213 (turbine oil), ISOVG46 or equivalent	←	ISO 3448 of ISO VG46	←	No specification
Change rate of length (at max. working pressure)	+3~-3%	←	←	←	←		
Other performance	Low-temperature resistance	Bend hose at minimum bending radius, 8 to 12 sec after leaving it for 24 hr at -40°C. Then perform the pressure durability test.	←	←	←	←	
	Ozone resistance of outer surface	Perform visual check at two-fold magnification after leaving it for 72 hr at 40°C under the ozone concentration 0.5 ppm.	←	←	←	Perform visual check at seven-fold magnification after leaving it for 70 hr at 40°C under the ozone concentration 0.5 ppm.	
	Hydraulic resistance of inner and outer surface	+35 to -15% of volume change rate after dipping for 72 hr at 100°C in No. 3 oil.	←	←	←	+35 to -15% of volume change rate after dipping for 70 hr at 100°C in ASTM No.3.	

Table of unit conversion

Length

m	in	foot	yard	mile
1	3.937×10	3.2808	1.0936	6.2×10^{-4}
2.54×10^{-2}	1	8.3333×10^{-2}	2.778×10^{-2}	1.6×10^{-5}
3.048×10^{-1}	1.2×10	1	3.3333×10^{-1}	1.9×10^{-4}
9.114×10^{-1}	3.6×10	3	1	5.7×10^{-4}
1.6093×10^3	6.3360×10^4	5.280×10^3	1.760×10^3	1

Weight

kg	ton (UK)	ton (USA)	lb	Ounce
1	9.842×10^{-4}	1.1023×10^{-3}	2.2046	3.5274×10
1.016×10^3	1	1.12	2.240×10^3	3.5838×10^4
9.072×10^3	8.9286×10^{-1}	1	2×10^3	3.2×10^4
4.536×10^3	4.464×10^{-4}	5×10^{-4}	1	1.6×10
2.835×10^3	2.79×10^{-5}	3.13×10^{-5}	6.25×10^{-2}	1

Pressure

Pa	MPa	bar	kgf/cm ²	psi	mmHg
1	1×10^{-6}	1×10^{-5}	1.0197×10^{-5}	1.4504×10^{-4}	7.5006×10^{-3}
1×10^5	1×10^{-1}	1	1.0197	1.4504×10	7.5006×10^2
9.8067×10^4	9.8067×10^{-2}	9.8067×10^{-1}	1	1.4223×10	7.3556×10^2
6.8948×10^3	6.8948×10^{-3}	6.4898×10^{-2}	7.0307×10^{-2}	1	5.1715×10
1.3332×10^2	1.3332×10^{-4}	1.332×10^{-3}	1.3595×10^{-3}	1.9341×10^{-2}	1

Force

N	dyn	kgf
1	1×10^5	1.0197×10^{-1}
1×10^{-5}	1	1.0197×10^{-6}
9.8066	9.8066×10^5	1

* is the SI unit.

Hydraulic hose products	Hydraulic Hose
	Airless-painting Hose
	Clean Hose
Adapter	Hose Guard
	Parts, Specially-Treated Parts
Assembling Machine, Jig, Tool	Assembling Method
	Assembling Method
Technical Document	Reference Document

Examples of problems when hose assembly is not used appropriately

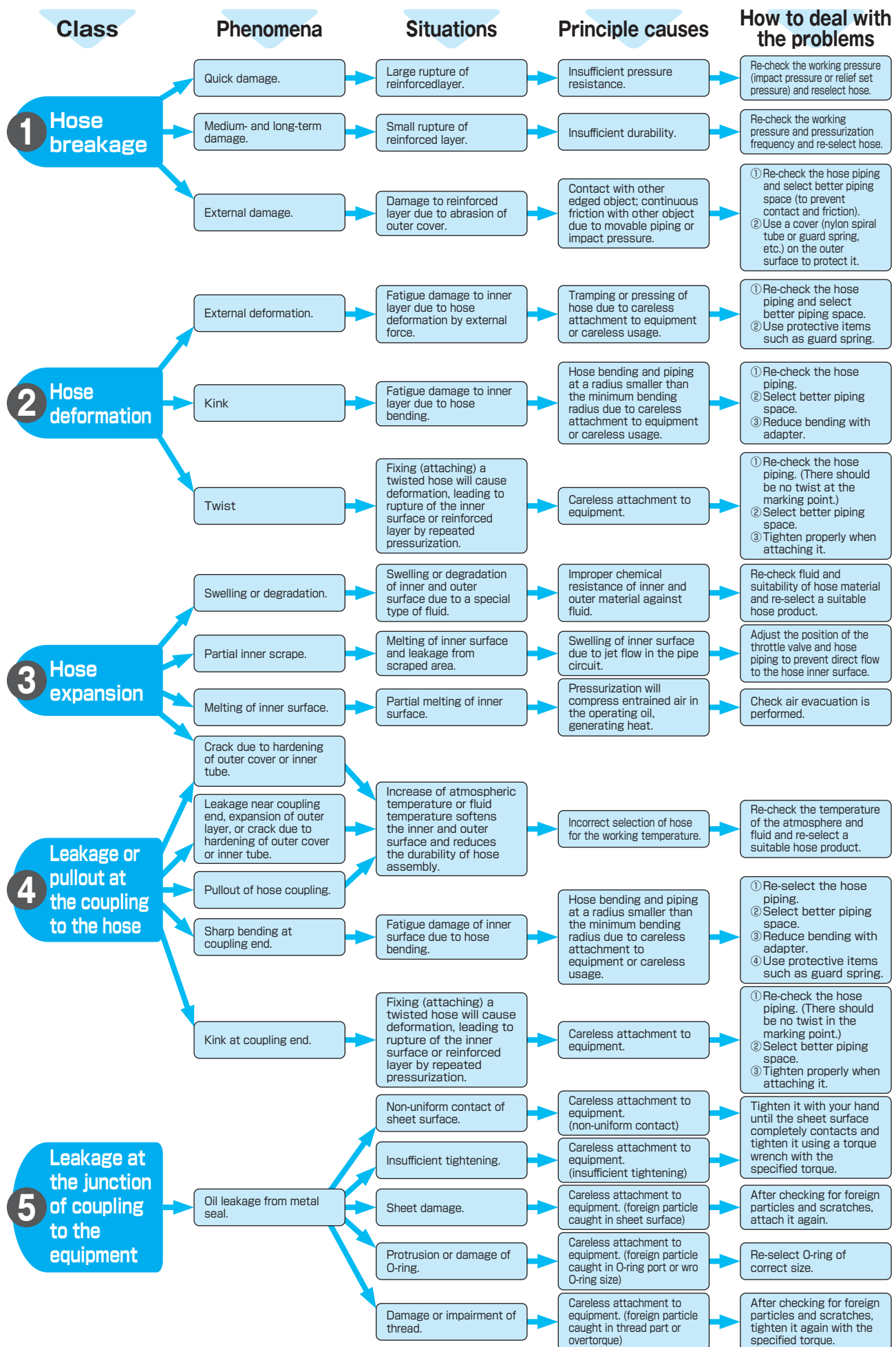

Chemical resistance list

Please refer to the attached chemical resistance list for the safe use of the products.
Special attention should also be paid to the explanation written below.

《Criteria of availability for each chemical》

- = No influence
- △ = Further confirmation required
- × = Not applicable
- = No data available

When consulting with us in case of △, following data are necessary for us to judge.

- 1 Pressure in operation, 2 Max. temperature in operation,
- 3 Concentration of chemicals, 4 Installation condition, 5 Applicatio.

1. The data shown here are based upon laboratory. Variations in temperature, pressure, fluids duration of exposure or other special conditions influence the results in the list and therefore no guarantee is expressed or implied.
2. Please be sure to evaluate the products in the condition at a real workplace before use.
3. In case of aqueous solution in the list, the chemicals are all in a saturated condition at a room temperature, unless otherwise stated.
4. The list only shows chemical resistance at the liquid condition of chemicals but not referring at all to the gas permeation quality. Do not use the products for the chemicals which is dangerous if the gas permeates through/from the products.
5. Please consult with us about the chemical resistance for the galvanized materials.

Campucka couplings are for the general operating oil and can not be used for any other kinds of liquids.

When using the aqueous glycol operating oil, the materials for the couplings should be stainless or black oxidizing ones specially arranged upon request.

Chemical resistance list (Guideline)

Chemicals (Weight concentration %, Temperature °C)	Hose materials					Hose couplings / Adapters		
	Nylon	Polyolefi	Urethane	PVC	Polyester	Steel	SUS304	SUS316
2-Aminophenyl Disulfide	○	○	△	-	-	-	-	-
A Acetaldehyde	△	×	×	×	○	○	○	○
Acetic Acid (10%, 20°C)	△	○	×	○	△	×	△	○
Acetic Acid (50%, 20°C)	×	△	×	-	-	×	△	△
Acetic Acid (50%, 70°C)	×	×	×	-	-	×	△	△
Acetic Acid (100%, 20°C)	×	×	×	-	-	×	△	△
Acetic Anhydride	×	△	×	×	×	×	△	△
Acetoamide	-	×	-	-	-	-	-	-
Acetone	△	△	×	×	△	○	△	△
Acetyl Bromide	×	×	×	-	-	-	-	-
Acetyl Chloride	×	×	×	×	×	○	-	△
Acetylene	○	○	○	-	○	○	○	○
Acrylonitrile	-	△	-	-	-	-	△	△
Alum	×	○	-	○	-	-	-	-
Aluminium Acetate	○	○	-	-	-	-	-	-
Aluminium Bromide	△	○	-	-	-	-	-	-
Aluminium Chloride	△	○	-	○	-	×	×	×
Aluminium Fluoride	△	○	-	-	-	△	×	×
Aluminium Nitrate	△	○	△	-	-	-	-	△
Aluminium Sulfate	○	○	-	○	-	×	○	○
Ammonia Anhydrous	○	○	-	-	-	-	○	○
Ammonia Gas Cold	×	×	×	-	△	○	○	○
Ammonia Gas Hot	×	×	×	-	△	○	△	△
Ammonia Liquid	○	○	-	-	-	-	○	○
Ammonia Water	△	○	△	-	△	△	△	△
Ammonium Carbonate	○	○	-	-	-	-	△	△
Ammonium Chloride	○	○	○	○	○	×	△	△
Ammonium Hydroxide	△	○	△	×	×	△	△	△
Ammonium Nitrate	○	○	○	○	△	○	△	△
Ammonium Persulphate	○	○	-	-	-	-	-	-
Ammonium Phosphate	○	○	○	○	△	×	△	△
Ammonium Sulfate	○	○	○	○	△	×	△	△
Amyl Acetate	○	×	×	×	△	×	-	○
Amyl Alcohol	△	△	△	○	○	△	-	-

- Hydraulic Hose
- Airless-painting Hose
- Clean Hose
- Adapter
- Hose Guard Parts, Specially-Treated Parts
- Assembling Machine, Jig, Tool
- Hose Assembling Method
- Technical Document
- Reference Document

Chemical resistance list

The table shows relative merits under condition that cardinal number of aqueous liquor is based on saturated status with ordinary temperature unless otherwise specified.

Chemicals (Weight concentration %, Temperature °C)	Hose materials					Hose couplings / Adapters		
	Nylon	Polyolefi	Urethane	PVC	Polyester	Steel	SUS304	SUS316
Amyl Borate	-	△	-	-	-	-	-	-
Amyl Naphthalene	-	△	-	-	-	-	-	-
Anethole	○	-	-	-	-	-	-	-
Aniline	x	x	x	△	x	x	△	△
Aniline Dyes	x	○	-	-	-	-	-	-
Animal oil (Lard oil)	○	○	○	○	○	x	-	△
Aqua Regia	x	x	x	-	-	-	-	-
Arsenic Acid	△	○	-	-	-	-	△	△
Asphalt	○	○	○	○	○	○	○	○
ASTM lubricant No.1	○	x	○	-	○	○	○	○
ASTM lubricant No.2	○	x	x	-	○	○	○	○
ASTM lubricant No.3	○	x	x	-	○	○	○	○
ASTM Standard fuel oil A	○	x	○	-	○	○	○	○
ASTM Standard fuel oil B	○	x	○	-	○	○	○	○
ASTM Standard fuel oil C	○	x	○	-	○	○	○	○
Ba Barium Hydroxide	○	○	-	-	-	x	-	○
Barium Chloride	○	○	○	○	○	x	-	△
Barium Sulfate	○	○	-	-	-	△	△	△
Barium Sulfide	○	○	-	-	-	-	-	-
Beet sugar oil	○	○	-	-	-	-	-	○
Benzene	△	x	x	x	△	△	△	△
Benzin	△	x	△	-	-	-	-	-
Benzoaldehyde	△	x	△	x	○	x	△	△
Benzoic Acid	○	○	x	○	x	x	△	△
Benzyl Alcohol	△	△	△	△	△	○	△	△
Benzyl Benzoate	-	-	-	-	-	-	-	-
Benzyl Chloride	x	-	-	-	-	-	-	x
Borax	○	○	○	△	○	△	-	△
Boric acid	○	○	○	○	○	x	△	△
Bromine	x	x	x	△	x	x	-	x
Bunker fuel	○	-	-	-	-	-	-	○
Buthane	○	△	-	-	-	○	○	○
Butyl Acetate	○	x	x	x	△	○	-	△
Butyl Acrylate	○	x	-	-	-	-	-	-
Butyl Alcohol	△	△	△	○	○	○	○	○
Butyl Cellosolve	△	-	-	-	-	-	-	△
Butyl Stearate	○	-	-	-	-	-	-	-
Ca Calcium Acetate	○	○	○	-	-	△	-	△
Calcium Arsenate	○	○	○	○	○	-	-	-
Calcium Bisulfite	○	○	○	△	○	x	-	△
Calcium Chloride	○	○	○	○	○	△	△	△
Calcium Hydroxide	○	○	△	○	△	△	△	△
Calcium Hypochlorite (20%, 20°C)	x	○	x	○	△	x	-	△
Calcium Nitrate	○	○	-	-	-	-	-	-
Calcium Sulfide	○	○	-	-	-	-	-	-
Cane sugar liquor	○	○	-	-	-	○	-	○
Carbitol	-	△	-	-	-	-	-	△
Carbon Dioxide	○	○	○	-	-	○	○	○
Carbon Oxide	○	○	○	-	-	○	○	○
Carbon Tetrachloride	x	x	x	△	x	△	△	△
Carbone Disulfide	x	x	x	x	△	○	○	○
Carbonic Acid	○	△	△	-	-	x	△	△
Castor Oil	○	○	△	○	△	○	△	△
Cellosolve	○	○	-	-	-	-	-	△
Cellosolve Acetate	△	-	x	-	-	-	-	-
Chloride gas (dry)	x	x	x	△	x	○	x	x
Chloride gas (wet)	x	x	x	-	-	-	x	x
Chloro acetone	-	x	-	-	-	-	-	-
Chlororform	△	x	x	△	△	x	△	△
Chlorosulfonic acid	x	x	-	-	-	-	x	x

The table shows relative merits under condition that cardinal number of aqueous liquor is based on saturated status with ordinary temperature unless otherwise specified.

Chemicals (Weight concentration %, Temperature °C)	Hose materials					Hose couplings / Adapters		
	Nylon	Polyolefi	Urethane	PVC	Polyester	Steel	SUS304	SUS316
Chlorotoluene	X	X	-	-	-	-	-	-
Chromic Acid (2%, 70°C)	X	X	X	△	X	X	X	△
Chromic Acid (2%, 50°C)	X	X	X	-	X	X	X	△
Chromic Acid (10%, 70°C)	X	X	X	-	X	X	X	△
Chromic Acid (25%, 70°C)	X	X	X	-	X	X	X	△
Citric acid	○	○	△	○	△	X	△	△
Coal-Tar	○	△	○	○	○	○	○	○
Copper Chloride	△	○	○	○	○	X	X	X
Copper Cyanide	○	○	-	-	-	-	-	○
Copper Sulfate	○	○	○	○	○	X	△	○
Corn oil	○	△	○	○	○	△	-	○
Cotton seed oil	○	△	○	○	○	○	△	△
Creosote	X	△	X	△	X	○	△	△
Cresol	X	X	X	△	X	△	△	○
Cyclohexane	○	X	△	△	○	○	-	△
Cyclohexanol	○	△	-	-	-	△	△	△
Cyclohexanone	○	X	X	-	○	△	-	-
D Decalin	○	△	-	-	-	-	-	-
Developer (Hypo)	△	○	△	-	-	-	-	-
Diacetone Alcohol	○	○	△	X	△	△	○	○
Dibenzine Ether	△	X	X	-	-	-	-	○
Dibutyl Ether	△	X	△	-	-	-	-	-
Dibutyl Phthalate	○	△	△	-	△	-	-	-
Dichlorobenzene	△	X	X	-	-	○	-	-
Diezthanol Amine	○	-	△	-	△	△	-	○
Diethyl Ether	△	△	△	△	△	○	-	△
Diethyl Sebacate	△	X	-	-	-	-	-	-
Diisopropyl Ketone	△	△	X	-	-	-	-	-
Dimethyl Formamide	X	△	X	-	-	-	-	-
Dinitrogen oxide (Nitrous Oxide)	○	X	X	○	○	X	△	○
Diocetyl Phthalate (DOP)	○	X	△	X	△	-	-	-
Diocetyl Sebacate (DOS)	○	X	△	-	-	-	-	-
Dipentene (Limonene)	△	X	X	-	-	-	-	-
Diphenyl	△	X	X	-	-	-	-	-
Diphenyl Oxide	-	-	-	-	-	-	-	-
Dowtherm (100°C)	-	-	-	-	-	-	-	-
Dowtherm (200°C)	-	-	-	-	-	-	-	-
E Epichlorohydrin	X	-	-	-	-	-	-	-
Ester Silicate	○	-	-	-	-	-	-	-
Ethanol Amine	X	X	-	-	-	-	-	-
Ethyl Acetate	○	△	X	X	△	○	△	△
Ethyl Acetoacetate	-	-	-	-	-	-	-	-
Ethyl Acrylate	-	-	X	-	-	-	-	-
Ethyl Alcohol	△	△	X	△	△	○	△	○
Ethyl Benzene	-	X	-	-	-	-	○	○
Ethyl Cellulose	-	○	-	-	-	-	-	△
Ethyl Chloride	○	X	X	X	X	○	○	○
Ethyl Oxalate	○	X	X	-	-	-	-	-
Ethyl Silicate	△	-	-	-	-	-	-	-
Ethylene Chlorohydrin	X	X	X	X	X	-	-	-
Ethylene Diamine	X	X	-	-	-	-	-	-
Ethylene Dioxide	X	△	X	X	X	△	△	△
Ethylene Glycol	○	○	○	○	○	△	△	△
Ethylene Oxide	○	X	X	-	△	△	-	△
F Fatty Acids	○	X	△	○	○	X	△	○
Ferric Chloride	△	○	-	○	-	X	X	X
Ferric Nitrate (II)	○	○	-	-	-	-	-	-
Fluorine	-	X	X	△	X	X	-	△
Fluoroboric acid	-	○	X	△	X	△	-	○
Formaldehyde (40%, 20°C)	X	△	X	○	△	○	△	△

Hydraulic Hose	Hydraulic hose products
Airless-painting Hose	Hydraulic hose products
Clean Hose	Hydraulic hose products
Adapter	Adapter
Hose Guard Parts, Specially-Treated Parts	Hose Guard Parts, Specially-Treated Parts
Assembling Machine, Jig, Tool	Assembling Machine, Jig, Tool
Hose Assembling Method	Hose Assembling Method
Technical Document	Technical Document
Reference Document	Reference Document

Chemical resistance list

The table shows relative merits under condition that cardinal number of aqueous liquor is based on saturated status with ordinary temperature unless otherwise specified.

Chemicals (Weight concentration %, Temperature °C)	Hose materials					Hose couplings / Adapters		
	Nylon	Polyolefi	Urethane	PVC	Polyester	Steel	SUS304	SUS316
Formic acid (25%, 20°C)	x	○	x	○	x	x	△	○
Formic acid (50%, 20°C)	x	○	x	-	-	x	△	○
Formic acid (90%, 20°C)	x	△	x	-	-	x	△	○
Freon11	△	-	-	△	△	○	○	○
Freon12	△	-	-	△	△	○	○	○
Freon21	△	-	-	△	△	○	○	○
Freon22	△	-	-	△	△	○	○	○
Freon113	△	-	-	△	△	○	○	○
Freon114	△	-	-	△	△	○	○	○
Furan	x	-	-	-	-	-	-	-
Furfural	x	x	x	-	-	△	△	△
Furfuryl Alcohol	○	○	○	○	○	-	-	-
G Gasoline	○	△	x	△	○	○	○	○
Gelatine	○	○	○	○	○	△	○	○
Glucose	○	○	○	○	○	○	○	○
Glue	○	○	-	○	○	○	-	△
Glycerine	○	○	△	○	○	○	○	○
Grease	○	△	△	○	○	○	○	○
H Heavy water	○	○	○	-	-	-	-	-
Heptane	○	x	○	△	○	○	○	○
Hexane	○	x	△	△	○	○	△	△
Hexyl Alcohol	△	△	-	-	-	-	-	-
Hydrazine	△	△	-	-	-	-	-	-
Hydrobromic Acid (20%, 20°C)	△	○	-	-	-	-	x	x
Hydrobromic Acid (20%, 70°C)	x	△	-	-	-	-	x	x
Hydrobromic Acid (37%, 20°C)	△	○	-	-	-	-	x	x
Hydrochloric (10%, 20°C)	△	○	x	○	x	x	x	x
Hydrochloric (20%, 20°C)	x	△	x	-	x	x	x	x
Hydrochloric (20%, 80°C)	x	x	x	-	x	x	x	x
Hydrochloric (38%, 20°C)	x	x	x	-	x	x	x	x
Hydrocyanic Acid	x	○	-	○	-	x	-	○
Hydrofluoric Acid (10%, 20°C)	x	△	x	△	x	x	x	x
Hydrofluoric Acid (20%, 20°C)	x	△	x	-	x	x	x	x
Hydrofluoric Acid (40%, 20°C)	x	△	x	-	x	x	x	x
Hydrofluoric Acid (Anhydrous)	x	x	x	-	-	x	-	x
Hydrogen	○	○	○	○	○	○	○	○
Hydrogen Peroxide (5%, 20°C)	○	○	△	○	○	x	△	△
Hydrogen Peroxide (5%, 50°C)	△	△	x	-	-	x	△	△
Hydrogen Peroxide (30%, 20°C)	x	△	x	△	x	x	△	△
Hydrogen Sulfide	△	○	-	○	△	△	△	△
Hydroquinone	○	○	-	-	-	-	-	-
Hypochlorous acid	△	○	x	-	-	-	-	-
I Isobutyl Alcohol	△	○	-	-	-	-	-	-
Isocyanates	○	○	○	-	-	-	-	-
Isooctane	○	x	x	-	○	○	△	△
Isopropyl Acetate	○	x	△	x	△	○	-	△
Isopropyl Alcohol	△	○	-	-	-	○	△	△
Isopropyl Ether	△	△	-	-	-	○	△	△
J JP fuel oil (1~6)	△	x	△	-	○	○	○	○
K Kerosene	○	△	○	-	-	-	○	○
Ketones	○	○	△	x	△	○	△	△
L Lacquer	△	△	△	x	△	△	-	-
Lactic Acid	△	△	-	○	○	△	△	△
Lard oil	○	○	○	○	○	○	-	△
Lead Acetate	○	○	-	-	-	x	△	-
Lead Arsenate	○	○	○	○	○	-	-	-
Lead Nit rate	○	○	-	-	-	-	-	-
Lead Sulfamate	○	○	-	-	-	-	-	-
Lead Sulfate	○	○	○	○	○	x	-	△
Linoleic acid Dipentene	△	△	-	-	-	-	-	-

The table shows relative merits under condition that cardinal number of aqueous liquor is based on saturated status with ordinary temperature unless otherwise specified.

Chemicals (Weight concentration %, Temperature °C)	Hose materials					Hose couplings / Adapters		
	Nylon	Polyolefi	Urethane	PVC	Polyester	Steel	SUS304	SUS316
Linseed oil	○	×	○	-	-	-	-	-
Liquid Chloride	×	×	×	-	-	-	-	-
Liquidified Petroleum Gas	○	△	-	-	-	-	○	○
Lubricant (Ether type)	△	×	×	-	△	○	○	○
Lubricant (mineral oil type)	○	×	○	○	○	○	○	○
Lye solutions	○	○	-	-	-	-	-	-
M Magnesium Chloride	○	○	○	○	○	△	×	×
Magnesium Hydroxide	○	○	△	△	○	○	-	△
Magnesium Sulfate	○	○	○	○	○	△	○	○
Maleic acid	○	○	△	○	△	○	△	△
Malic Acid	○	○	-	-	-	△	△	△
Mercaptane	-	×	-	-	-	-	-	-
Mercuric Chloride	○	○	○	△	○	×	×	×
Methane	○	○	○	×	○	△	-	△
Methyl Acetate	○	△	×	×	△	△	-	○
Methyl Alcohol	△	△	×	×	△	△	△	△
Methyl Bromide	△	×	×	×	×	-	-	○
Methyl Chloride	×	×	×	×	×	△	○	○
Methyl Iso Butyl Ketone (MIBK)	△	△	×	×	△	△	-	△
Methyl Ethyl Ketone (MEK)	△	△	×	×	△	○	△	△
Methylene Dichloride	×	△	×	-	-	-	-	-
Methyl Metacrylate	○	×	-	-	-	-	-	-
Methyl Sulfate	△	×	×	-	○	-	-	-
Mineral oil	○	△	○	○	○	○	○	○
Monochloro Acetic Acid	×	×	×	×	×	-	-	-
Monochloro Benzene	×	×	×	-	-	-	-	-
Monoethanol Amine	○	△	-	-	-	-	-	-
N Naphtha	○	×	△	×	△	○	△	△
Naphthalene	○	△	△	×	△	○	-	△
Naphthenic acid	-	○	-	-	-	-	-	-
Natural gas	○	○	-	-	-	-	○	○
n-Hexa Aldehyde	-	×	-	-	-	-	-	-
Nickel Acetate	○	○	-	-	-	-	-	△
Nickel Chloride	×	○	-	×	×	×	-	×
Nickel Sulfate	○	○	-	-	-	×	△	△
Nitric acid (10%, 20°C)	×	○	×	○	△	×	△	○
Nitric acid (10%, 70°C)	×	△	×	-	-	×	△	○
Nitric acid (30%, 20°C)	×	△	×	○	×	×	△	○
Nitric acid (30%, 70°C)	×	×	×	-	×	×	△	○
Nitric acid (61%, 20°C)	×	×	×	-	×	×	△	○
Nitric acid (fuming, 20°C)	×	×	×	-	×	×	△	○
Nitrobenzene	×	×	×	×	×	○	△	△
Nitroethane	-	×	-	-	-	-	-	-
Nitrogen	○	○	○	○	○	○	○	○
Nitromethane	-	×	-	-	-	-	-	-
Nitropropane	-	×	-	-	-	-	-	-
O Octyl Alcohol	×	△	-	-	-	-	-	△
Oleic Acid	○	△	△	△	○	△	△	△
Olive Oil	○	○	○	-	-	-	○	○
Oxalic Acid	○	○	△	○	△	△	×	×
Oxygene	△	△	△	-	-	-	○	○
Ozone	△	△	△	△	○	△	△	○
P Palm oil	○	△	-	-	-	△	-	△
Palmitin Acid	○	○	○	○	○	△	△	△
Pentane	○	×	○	△	○	○	-	△
Perchloroethylene	×	×	×	△	×	○	-	△
Petroleum	○	×	○	○	○	○	-	-
Phenol	×	△	×	△	×	×	△	△
Phenyl Hydrazine	-	-	-	-	-	-	-	-
Phorone	-	-	-	-	-	-	-	-

Hydraulic hose products

- Hydraulic Hose
- Airless-painting Hose
- Clean Hose
- Adapter
- Hose Guard Parts, Specially-Treated Parts
- Assembling Machine, Jig, Tool
- Hose Assembling Method
- Technical Document
- Reference Document

Chemical resistance list

The table shows relative merits under condition that cardinal number of aqueous liquor is based on saturated status with ordinary temperature unless otherwise specified.

Chemicals (Weight concentration %, Temperature °C)	Hose materials					Hose couplings / Adapters		
	Nylon	Polyolefi	Urethane	PVC	Polyester	Steel	SUS304	SUS316
Phosphoric Acid (50%, 20°C)	△	○	×	○	×	△	△	△
Phosphoric Acid (50%, 70°C)	×	○	×	—	×	×	△	×
Phosphoric Acid (75%, 20°C)	×	○	×	—	—	×	△	△
Phosphorobenzene	○	○	△	—	—	—	—	△
Pickling Acid (Nitric acid 20% / Fluoric acid 4%)	×	○	—	—	—	—	—	—
Pickling Acid (Nitric acid 40% / Fluoric acid 15%)	×	○	—	—	—	—	—	—
Picric Acid	×	△	×	○	×	△	△	△
Pine oil	×	×	—	—	—	△	△	○
Pinene	○	×	—	—	—	—	—	—
Piperidine	△	△	—	—	—	—	—	—
Potassium Bichromate	△	○	△	—	×	○	—	△
Potassium Chloride	○	○	○	○	○	×	△	○
Potassium Cyanide	○	○	—	—	—	△	△	△
Potassium Hydroxide	△	○	△	△	×	△	△	△
Potassium Nitrate	△	○	○	○	○	△	△	△
Potassium Permanganate (5%, 20°C)	×	△	×	○	—	△	△	△
Potassium Sulfate	○	○	○	○	○	△	△	△
Propane	○	○	△	○	○	○	○	○
Propyl Acetate	○	×	×	—	—	○	—	○
Propyl Alcohol	△	△	×	—	—	△	○	○
Propylene	○	—	—	—	—	○	○	○
Pyridine	×	○	△	×	△	○	—	△
Pyrrole	—	△	—	—	—	—	—	—
Salicylic Acid	—	○	—	—	—	—	△	△
Salt Water (Brine)	○	○	—	—	—	—	△	△
Sea Water	○	○	○	○	○	△	○	○
Silicone Grease	○	△	—	—	—	—	—	—
Silicone oil	○	△	—	—	—	—	—	—
Silver Nitrate	△	○	—	—	—	—	—	—
Soap aqueous solution	○	△	○	○	○	○	○	○
Soda Ash	○	○	○	—	—	—	△	△
Soda (Carbonated) water	○	○	○	○	○	—	—	—
Sodium Bicarbonate	○	○	○	○	○	△	—	△
Sodium Bisulphate	○	○	○	—	—	—	—	—
Sodium Carbonate	○	○	○	○	○	○	△	△
Sodium Cyanide	○	○	○	○	○	○	—	△
Sodium Hydroxide (10%, 20°C)	○	○	×	○	△	△	△	△
Sodium Hydroxide (30%, 20°C)	○	○	×	—	—	—	—	—
Sodium Hydroxide (30%, 70°C)	×	×	×	—	—	—	—	—
Sodium Hypochlorite (5%, 20°C)	×	○	×	○	△	×	×	△
Sodium Hypochlorite (5%, 70°C)	×	△	×	—	—	×	×	△
Sodium Metaphosphate	○	○	—	—	—	—	—	△
Sodium Nitrate	○	○	○	○	○	○	○	○
Sodium Perborate	○	○	—	—	—	—	—	△
Sodium Peroxide	×	○	—	—	—	○	—	△
Sodium Phosphate	○	○	○	○	○	×	△	△
Sodium Silicate	○	○	○	○	○	△	—	△
Sodium Sulfate	○	○	○	○	○	○	△	△
Sodium Sulfide	○	○	○	○	○	△	△	△
Sodium Sulfite	×	×	—	—	—	—	○	○
Sodium Thiosulfate	○	○	○	○	○	×	—	△
Soy Bean oil	○	○	—	—	—	—	△	○
Stannic Chloride	△	○	—	—	—	—	×	×
Stannous chloride	△	○	○	○	○	×	×	×
Stearic Acid	○	○	○	○	○	×	△	△
Styene	△	△	△	—	△	△	—	△
Sulfur	○	○	○	○	○	○	△	△
Sulfur Chloride	—	×	—	—	—	—	—	△
Sulfur Dioxide	×	×	×	△	△	△	—	△
Sulfur Trioxide	△	○	×	○	×	△	△	△

The table shows relative merits under condition that cardinal number of aqueous liquor is based on saturated status with ordinary temperature unless otherwise specified.

Chemicals (Weight concentration %, Temperature °C)	Hose materials					Hose couplings / Adapters		
	Nylon	Polyolefi	Urethane	PVC	Polyester	Steel	SUS304	SUS316
Sulfuric Acid (10%, 20°C)	△	△	X	△	X	X	X	X
Sulfuric Acid (10%, 70°C)	X	△	X	-	-	X	X	X
Sulfuric Acid (30%, 20°C)	X	△	X	△	X	X	X	X
Sulfuric Acid (30%, 70°C)	X	X	X	-	-	X	X	X
Sulfuric Acid (98%, 20°C)	X	X	X	-	-	X	X	X
Sulfuric Acid (fuming, 20°C)	X	X	X	-	-	X	X	X
Sulfurous Acid	X	X	X	△	△	△	△	△
▶ Table Salt (Common Salt)	○	○	○	○	○	△	△	△
Tannic Acid	○	○	△	○	△	△	△	△
Tartaric acid	△	○	○	○	○	△	△	△
Terpineol	○	X	-	-	-	-	-	-
TetrachloroEthane	△	X	-	-	-	-	-	-
Tetraethyl Lead	△	△	-	-	-	-	-	△
Tetrahydro Furan	△	X	-	-	-	-	-	-
Tetraline	△	X	-	-	-	-	-	-
Tetrametyl Lead	○	-	○	-	○	-	-	-
Thionyl Chloride	X	X	-	-	-	-	-	-
Toluene	△	X	X	X	△	○	○	○
Triacetine	-	-	-	-	-	-	-	-
Tributoxyethyl Phosphate (TBEP)	○	-	-	-	-	-	-	-
Tributyl Phosphate (TBP)	○	X	△	X	△	○	-	○
Trichloroacetate	X	△	X	△	X	-	△	△
Trichloroethylene	△	X	X	△	X	○	-	○
Tricresyl Phosphate (TCP)	○	X	△	-	-	-	-	-
Triethanolamine	○	X	-	-	-	○	-	○
Tung oil	○	○	-	-	-	-	○	○
Turpentine oil	○	X	○	○	○	△	-	○
▶ Uric acid	○	○	X	○	X	-	-	-
▶ Vegetable oil	○	○	-	-	-	-	-	-
▶ Xylene	△	X	X	X	△	○	○	○
▶ Zeolite	○	○	-	-	-	-	-	-
Zinc Acetate	○	○	-	-	-	-	-	-
Zinc Chloride	△	○	○	○	○	△	△	○
Zinc Sulfide	△	○	△	○	△	X	△	△

Hydraulic Hose	Hydraulic Hose products	Hydraulic Hose	Adapter	Hose Guard Parts, Specially-Treated Parts	Assembling Machine, Jig, Tool	Hose Assembling Method	Technical Document	Reference Document
Airless-painting Hose								
Clean Hose								

NITTA CORPORATION

<https://www.nitta.co.jp>

4-4-26 Sakuragawa Naniwa-ku, Osaka 556-0022 Japan Phone: +81-6-6563-1241 • Fax: +81-6-6563-1243

NITTA CORPORATION OF AMERICA

7605 Nitta Drive,
Suwanee, GA 30024, U.S.A.
Phone: +1-770-497-0212 • Fax: +1-770-623-1398
<https://www.nitta.com>

NITTA (SHANGHAI) MANAGEMENT CO.,LTD.

Room 2705, Shenggao International Building,
No.137 Xianxia Road, Shanghai 200051, P.R.China
Phone: +86-21-6229-6000 • Fax: +86-21-6229-9606

TAIWAN NITTA FILTER CO.,LTD.

Chia Hsin Building, 10FL, Room No.1005
96 Chung Shan North Road Section 2
Taipei, Taiwan, R.O.C.
Phone: +886-2-2581-6296 • Fax: +886-2-2563-4900
<https://www.nitta.com.tw>

NITTA INDUSTRIES EUROPE GmbH

Hansaallee 201
40549 Düsseldorf, Germany
Phone: +49-211-537535-0 • Fax: +49-211-537535-35
<https://www.nitta.de>

NITTA CORPORATION (THAILAND) LIMITED

7/472 Moo6, Tambol Mabyangporn,
Amphur Pluadaeng, Rayong Province 21140, THAILAND
Phone: +66-38-018-301 • Fax: +66-38-018-304
<https://www.nittathai.com>

NITTA CORPORATION INDIA PVT LTD

Gat No.191, 192, and 193, Plot No B,
Village Vadhu Khurd, Taluka Haveli Dist Pune-412216,INDIA
Phone: +91-20-6731-3400 • Fax: +91-20-6731-3401
<https://www.nitta.co.in>

19095000F