

HEATING PRESS NPS-2005R OPERATOR'S MANUAL

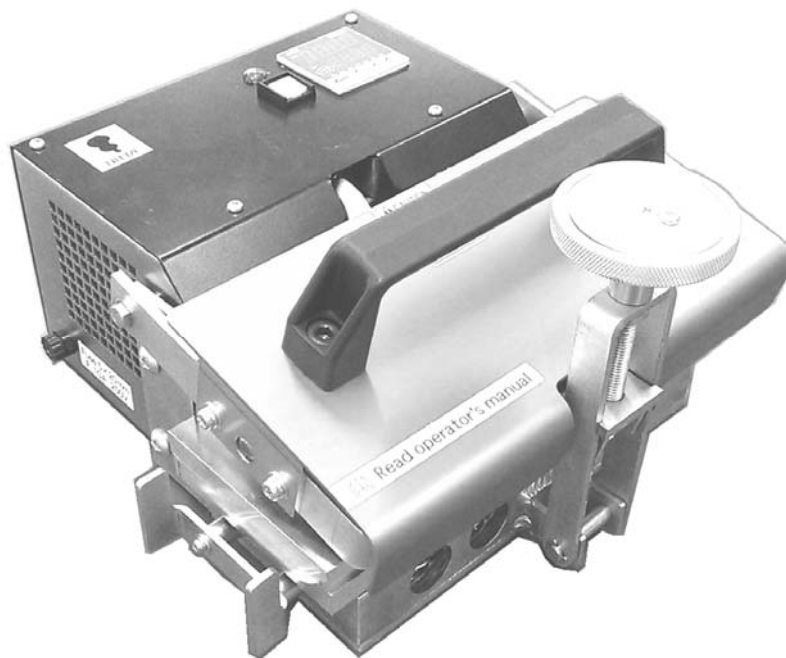

Thoroughly read this operator's manual before operating the press.



To use endless splicing tools safely, be sure to hand this manual to the operator or worker.

NITTA CORPORATION

Table of Contents

1. Safety Precautions	3
2. Confirmation of Product	6
3. Specifications	7
4. Operating Environment	8
5. Storage Environment	8
6. Name of each Part	9
7. Equipment	10
8. Operating Procedures	11
9. Parts List	13
10. Troubleshooting	15
11. Inspection	16

1. Safety Precautions

We would like to thank you for having purchased our Integral Heating and Cooling Press **NPS-2005R**.

Thoroughly read this manual, especially the chapter on Safety Precautions, to use this machine safely.



This indicates a hazardous situation which, if improperly handled, will result in death or serious injury.



This indicates a potentially hazardous situation which, if improperly handled, will result in minor injury or property damage.

WARNING



Do not use this machine for any use other than belt endless splicing. Any use not intended for the prescribed purpose may invite an unexpected accident.
Improper use may render ineffective the safety protection features of the product.



This machine is not intended for use by the physically, sensory or mentally handicapped. They must have the supervision of a person responsible for their safety, if they use this machine.
Failure to do this may cause fire, electric shock or injury.



Do not allow children to handle this machine. Keep this machine out of reach of children.
Children should not play with this machine.
Failure to do this may cause fire, electric shock or injury.



A person with technical knowledge and skills should always operate, maintain and inspect this machine.
Handling by a person not having technical knowledge may cause fire, electric shock or injury.



Strictly avoid disassembling or remodeling this machine.
Disassembling or remodeling this machine may cause fire or electric shock.
When repair or check is required, please contact your local distributor, agent in your area or our company.



In the event of trouble (smoke, fire or nasty smell, etc.), please immediately disconnect the power plug and contact your local distributor, agent in you area or our company for inspection or repair.
Failure to do this may cause fire or electric shock.



WARNING

When not using or carrying this machine, be sure to set the hook and turn the rotary handle until it slips to securely clamp the heat plate.
Failure to do this may cause injury.



WARNING

Confirm that the power supply to be used is within the designated of specification for this machine.

Failure to do this may cause fire or electric shock.

Model	Power supply
NPS-2005R-1	100 - 120V 50 / 60Hz
NPS-2005R-2	200 - 240V 50 / 60Hz



WARNING

Avoid using the press in the following environment.

Failure to do this may cause fire or electric shock.

- In an atmosphere of inflammable or ignitable gas
- In an atmosphere of corrosive gas
- In ambient temperature of 5°C or below
- In ambient temperature of 40°C or above
- In an atmosphere of high humidity (environment where humidity exceeds 85%)
- In an environment subject to wet conditions from steam, water droplets or dew condensation, etc.



WARNING

Be sure to wear heat-resistant gloves when operating this press.

Failure to do this may cause burns.



WARNING

When operating this press, avoid touching the heat plate area even if wearing heat-resistant gloves.

Failure to do this may cause burns, even if wearing heat-resistant gloves, since press heat plates get heated to the press's preset temperature once the press is plugged in.



WARNING

Avoid operating the press at the place close to combustible material.

Failure to do this may cause fire.



WARNING

Always use the pre-setter designed for this product.

Failure to do this may cause fire or electric shock.

Use of a pre-setter made for other products or by another manufacturer may render ineffective the safety protection features of the product.



WARNING

Use a dry cloth for cleaning this machine. Strictly avoid using alcohol, benzene, thinner or other inflammable solvents.

Using inflammable solvents may cause fire.



Impressed voltage is directly applied to the power cable. Observe the following precautions not to damage the cable.

Failure to do this may cause fire or electric shock.

- Disconnect the power plug by hand.
- Avoid pulling the cable to disconnect the power plug.
- Avoid modifying the power plug or replacing the plug with one from another manufacturer.
- Avoid placing anything on the power cable.
- Avoid bending the power cable.
- Take care to prevent the power cable from touching the heat plate of the press.



Connect the power plug to the socket correctly.

Failure to do this may cause electric shock.



The power cable of this machine uses a grounded connection plug. Connect the power plug correctly into a grounded connection socket.



Use a conversion plug when the plug shape does not match the socket.

Failure to do this may cause electric shock.

The plug shape of the attached power cable is as follows. The conversion plug is not attached. When a conversion plug is necessary, users must provide their own.

Model	Plug type	Plug illustration
NPS-2005R-1	A Type	
NPS-2005R-2	CEE7 (S Type)	



Never handle this machine or the plug, cable, etc. with wet hands.

Failure to do this may cause electric shock.



Never use this machine if it is wet.

Failure to do this may cause electric shock or fire.

CAUTION



Exercise care not to pinch your hands between the top cover and control box or the upper and lower heat plates.
Failure to do this may cause injury.

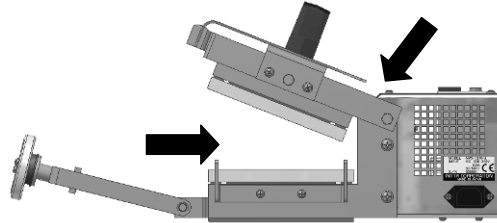

Avoid inserting your hands into the opening on the front face of the press.
Failure to do this may cause burns.

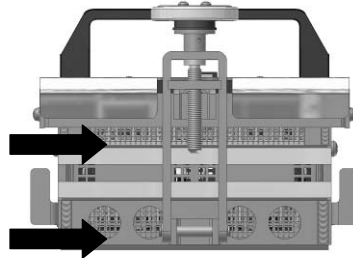

Avoid using this machine outdoors.
This product is not intended for the use outdoors.



Avoid dropping this machine or giving it a strong jolt.
Failure to do this may cause fire or electric shock.



Take measures to prevent this machine from dropping or falling, and do not install or operate the press in an unstable location.
Failure to do this may cause injury, fire or electric shock.



Carry out the inspection described on page 18 of this manual before operating this machine.
Failure to do this may cause fire or electric shock.



Do not use this machine for the endless splicing of belt of other manufacturers.
Splice defects may occur if this machine is used for endless splicing of belts from other manufacturers.
This may reduce the function and performance of the belt, or render it unusable.

2. Confirmation of Product



Before operating the press, check that the product is exactly what you have ordered. Using this product other than those specified in this manual may cause fire, electric shock, injury or burn.

2-1) Confirmation of Product

On opening the package, confirm the following points.

- 1) Are descriptions on the nameplate the same as those of item ordered?
Confirm the model and power supply specification.
- 2) Is there any breakage or anything missing?
The package contains this manual, the press and power cable.
- 3) Have screws and nuts loosened during shipping?

We double-check all items during inspection and shipment of products. In the event of any defect or failure, please contact your local distributor, agent in your area or our company.

2-2) Confirmation of the nameplate

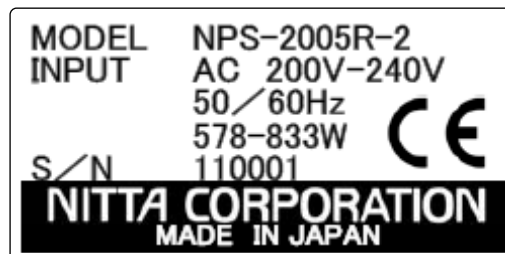
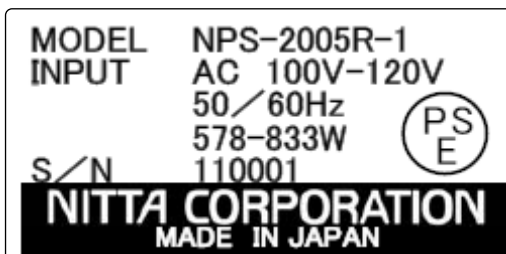

MODEL: Press model
INPUT: Input power supply specification and power consumption
S/N: Serial number

2-3) Press model

There are two kinds of models with a different input power supply.
The specification of the power supply is described by the input.

2-4) Notes for inquiry

When making inquiries, Please contact us with both the press model and serial number.

3. Specifications

3-1) Outline of the press

- (1) The NPS-2005 press is specially designed for the joining of NITTA's CFTG belts using 200mm long "fingers."
- (2) This machine is applicable with the following belt endless splicing specifications.
 Joint specification: Finger shape: 200 mm long × 10 mm pitch
 Maximum belt width: 60 mm or less
 Maximum belt thickness: 6 mm or less
- (3) Finger-endless splicing requires the finger puncher and pre-setter* of another-sales.
The pre-setter is required for each width belt that is to be made endless-spliced.

3-2) Main specifications of the Press

Model	NPS-2005R-1	NPS-2005R-2
Input power supply	100 - 120V	200 - 240V
	50 / 60Hz	50 / 60Hz
	578 – 833W	578 – 833W
Fuse	φ5.2 × 20mm F 0A, 250V*	
Preset temperature	175°C	
Outer dimensions	With the press closed: 301 mm wide × 300 mm long × 180 mm high With the press opened: 301 mm wide × 435 mm long × 266 mm high	
Weight	9.5 kg	

* When replacing the fuse, use the type listed in the specification shown above.

4. Operating Environment

Ambient temperature	5 – 40°C (no dew condensation)
Ambient humidity	15 – 85%R.H.
Working place	Indoor (place without dust and water)
Atmosphere	No inflammable, combustible or corrosive gas and steam



Avoid using this machine in the following environment.

Failure to do this may cause fire or electric shock.

- In the environment of inflammable or combustible gas
- In the environment of corrosive gas
- In the ambient temperature of 5°C or below
- In the ambient temperature of 40°C or above
- In the environment of high humidity (humidity exceeds 85%)
- In the environment of wetting by steam, water drop or dew condensation, etc.

5. Storage Environment

Ambient temperature	5 - 40°C (no dew condensation)
Ambient humidity	15 - 85%R.H.
Working place	Indoor (place without dust and water)
Atmosphere	No inflammable, combustible or corrosive gas and steam



When not in use, store this machine under the above conditions.

Poor storage conditions may cause mechanical disorders in the machine and may result in electric shock or fire.



When not using or carrying the machine, be sure to set the hook and turn the rotary handle until it slips.

Insufficient clamping may cause injury.



Before operating the machine, be sure to conduct the prior-to-use inspection and confirm the normal performance.

In the event any abnormality is found in the prior-to-use check, please immediately contact your local distributor, agent in your area or our company.

6. Name of each Part

6-1) Left side view of the press

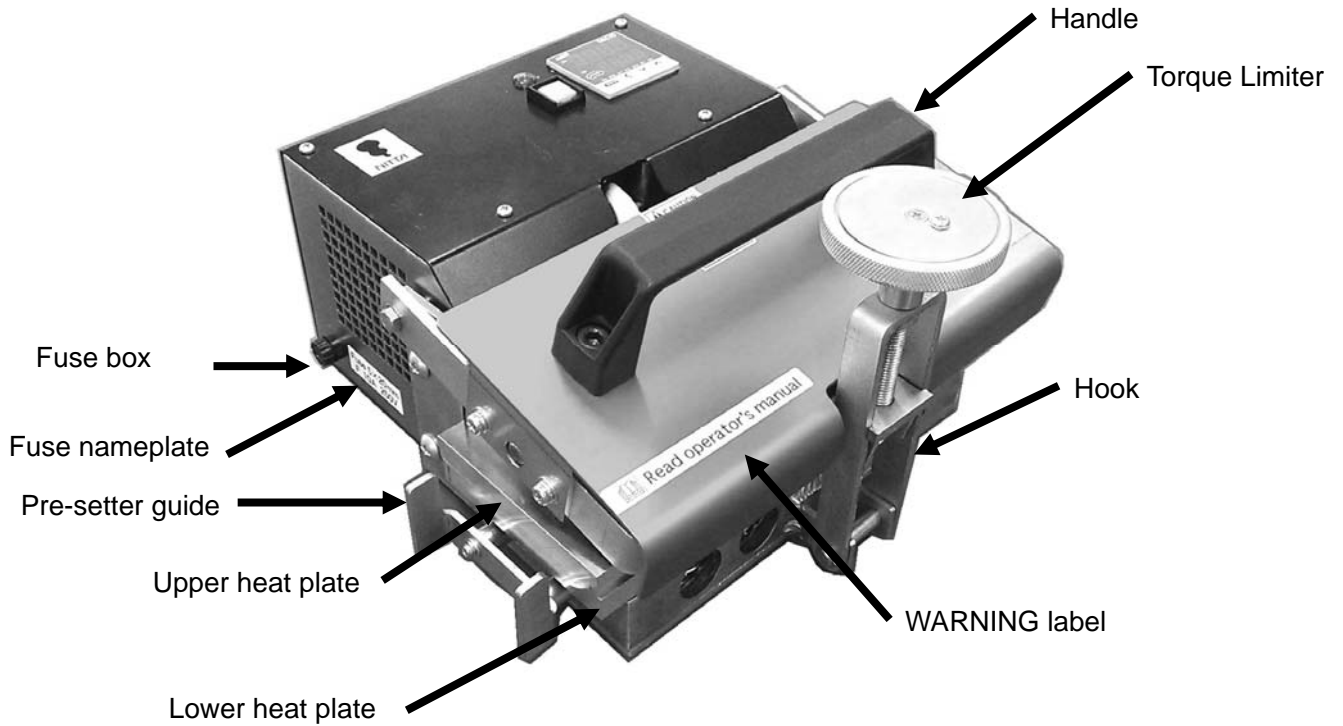

6-2) Right side view of the press

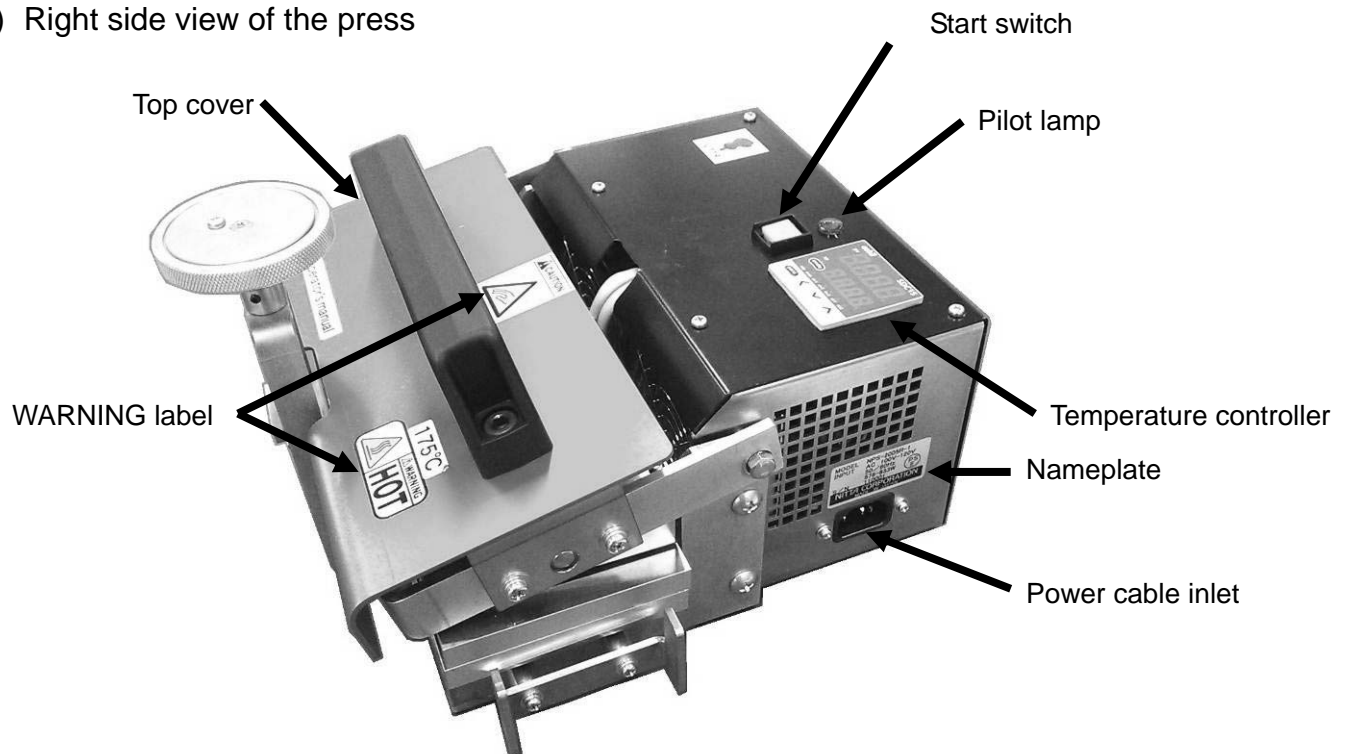

6-3) Temperature controller

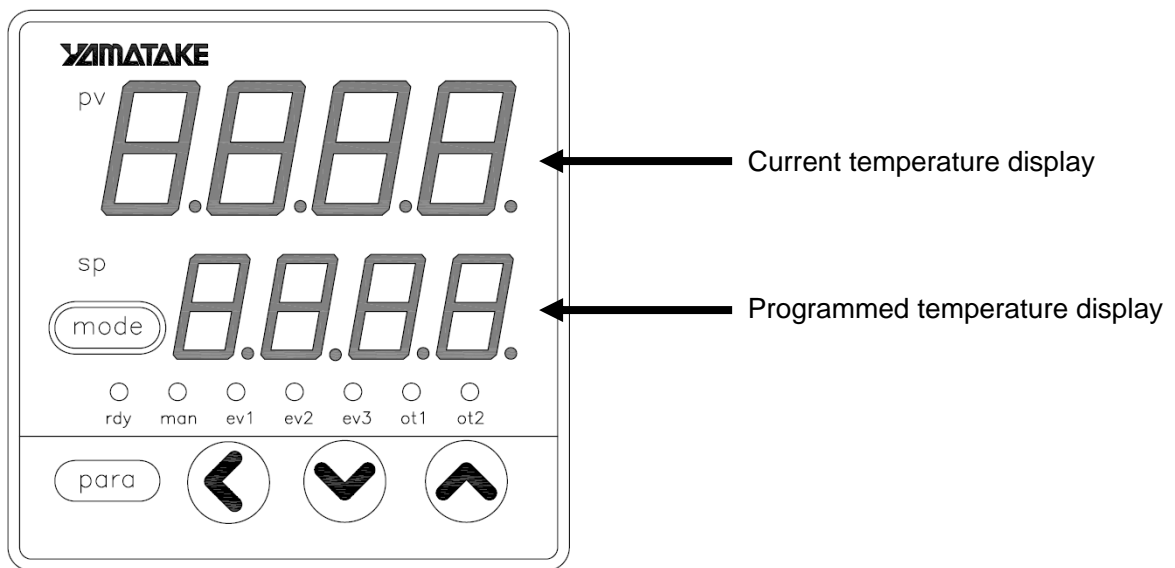

7. Equipment

These tools are necessary for correctly following the press procedures.

- NPS-2005R Press
- PS-200 Pre-Setting Mold
- One Pair of Sharp Scissors
- Mold Release Agent

8. Operating Procedure



WARNING Be sure to connect to a grounded outlet.

8-1) Pre-heating

Before preparing the belt ends, close the press and plug in the cord to begin pre-heating. The temperature control unit will run a diagnostic check for 6 seconds before heating.

A temperature of 175°C is recommended for joining LVR-60 material and has already been programmed into the controller. The upper readout on the unit indicates the current temperature. The lower readout indicates the programmed temperature of the bottom heating plate. This press takes approximately 10 to 15 minutes to pre-heat properly.

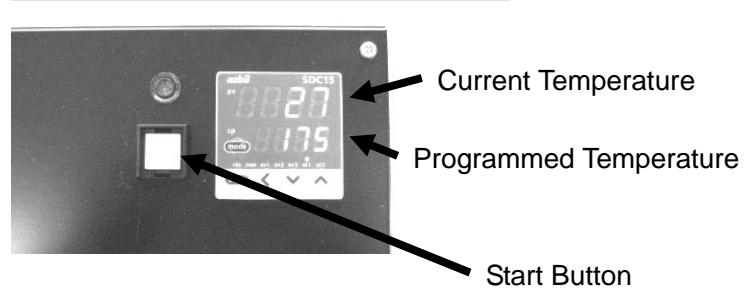

8-2) Preparation of fingers

Cut 5 to 10mm off the tips of each finger using a pair of scissors. This will help when matching the belt ends in the pre-set mold. (if the bottom fabric layer sticks out of the top surface it may lead to cracking or peeling failure.)



CAUTION Please ensure that only the very tips of the fingers are removed. Material will flow into any cavities to provide a smooth splice. Too much flow will weaken the bond, however. If this occurs, small bubbles will be seen between the fingers.

8-3) Securing fingers

Loosen clamps on lower mold of pre-setter and slide finger-prepared ends in fabric side down. Push ends together at center of mold (between marks on mold). Use a thin metal edge (such as steel ruler or screwdriver) to push tips of fingers or aramid fibers back between fingers if needed. Fasten clamps to hold belt in place.

If the tip of a finger or aramid fibers stick out from the surface, push them back between the fingers using a thin plate (steel measuring scale, screwdriver, etc.). Secure the belt with clamps on each end of the mold, cover belt material with fabric and replace top guide plate.

Cover top of belt material with 1mm thick silicone mat, making sure the mat faces matte side down.

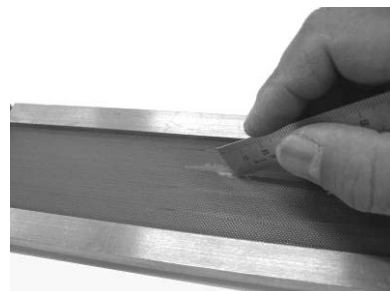
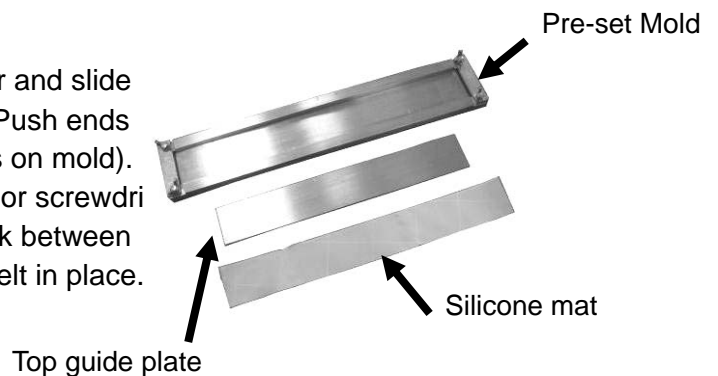

8-4) Mold positioning

After the actual temperature reaches the programmed value, open the press and insert the mold with belt. The mold must be properly placed between the metal position guides, and marks on the mold should be located within the heating plates to heat the entire finger area properly. Fasten hook and turn pressure knob clockwise until it slips.

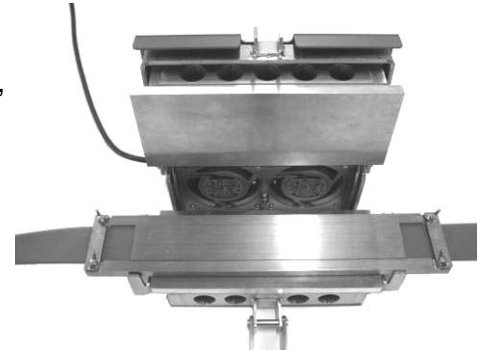

8-5) Start heating cycle

Simply push the start button on the press to initiate a cycle. Make sure the green pilot lamp above the yellow start button is turned on.



WARNING

Be sure to wear heat-resistant gloves when operating the press.

Failure to do this may cause burn.

8-6) Heating and cooling

After maintaining the programmed temperature for 10 minutes, the heat shuts off and cooling fans start automatically.



WARNING

The operator should not leave the machine unattended while in use.

Take measures to prevent other people from touching the machine accidentally. Failure to do this may cause burns to others.



CAUTION

Do not touch or open the press until the current temperature is below 80°C. This takes about 15 minutes. Disconnecting the electricity will then stop the cooling fans.

8-7) Discontinuing operation of the machine while in use

Disconnect the plug if it becomes necessary to discontinue operation of the machine while it is in use.

* **Even if the plug is disconnected during operation, preset data of preset temperature and hold time are maintained.**



WARNING

When operation is discontinued during use, the machine is kept at high temperature. Be sure to wear heat-resistant gloves when handling the machine. Failure to do this may cause burns.



WARNING

The operator should take measures to prevent other people from touching the machine accidentally, until the machine temperature lowers to near room temperature (about two hours).

Failure to do this may cause burns to others.



CAUTION

If machine operation is discontinued during the process of splicing a belt, do not use the belt.

The splice may become defective, reducing the function and performance of the belt, or rendering it unusable.

8-8) Remove mold

Turn the knob counterclockwise, release the clamp and open the press.

8-9) Finishing

Remove the belt from mold and inspect the condition of the joint. There must not be any large bubbles on the surface, cord filaments sticking out, cracks or grooves between the fingers. After the visual inspection, trim any polyurethane material from the edges using scissors.

9. Parts List

NPS-2005R PARTS LIST

No.	PARTS NAME	PARTS NUMBER	pcs	REMARKS
1	BOTTOM FRAME	NPS-2005-PARTS-1	1	
2	TOP FRAME	NPS-2005-PARTS-2	2	
3	BOTTOM COVER	NPS-2005-PARTS-3	1	
4	TOP COVER	NPS-2005-PARTS-4	1	
5	BOTTOM HEAT PLATE	NPS-2005-PARTS-5	1	
6	TOP HEAT PLATE	NPS-2005-PARTS-6	1	
7	CONTROL BOX	NPS-2005-PARTS-7	1	
8	FAN GUARD PLATE	NPS-2005-PARTS-8	1	
9	CONTROL PANEL	NPS-2005-PARTS-9	1	
10	FAN GUARD	NPS-2005-PARTS-10	1	
11	RELAY MOUNT	NPS-2005-PARTS-11	1	
12	HEATER	NPS-2005-PARTS-12	2	
13	HEAT SINK	NPS-2005-PARTS-13	2	
14	HEAT INSULATOR For HEAT PLATE	NPS-2005-PARTS-14	4	
15	HEAT INSULATOR For CONTROL BOX	NPS-2005-PARTS-15	2	
16	GUIDE ARM	NPS-2005-PARTS-16	1	
17	GUIDE ARM SPACER	NPS-2005-PARTS-17	2	
18	COVER STAY	NPS-2005-PARTS-18	2	
19	COVER	NPS-2005-PARTS-19	1	
20	ADJUSTER	NPS-2005-PARTS-20	1	
21	HOOK	NPS-2005-PARTS-21	1	
22	PRESS BOLT	NPS-2005-PARTS-22	1	
23	HINGE PIN	NPS-2005-PARTS-23	1	
24	PRESETTER GUIDE	NPS-2005-PARTS-24	2	
25	PRESETTER GUIDE SPACER	NPS-2005-PARTS-25	4	
26	VENTILATION HOLE METAL MESH	NPS-2005-PARTS-26	2	
27	SURGE PROTECTOR BRACKET	NPS-2005-PARTS-27	1	
28	TORQUE LIMITER ASSY	NPS-2005-PARTS-28	1	
29	ARCH GRIP	NPS-2005-PARTS-29	1	IMAO:AGS200
30	HEAT CONTROLLER	NPS-2005-PARTS-30	1	YAMATAKE:G15TV0TA0200
31	TEMPERATURE SENSOR	NPS-2005-PARTS-31	1	HAYASHI DENKO:ST6-J-S3.2-100-0.5JX-G
32	SSR	NPS-2005-PARTS-32	1	OMRON:G3NA-210B-UTU 5-24V
33	PUSH SWITCH	NPS-2005-PARTS-33	1	IDEC:MA2B-M119Y
34	PILOT LAMP	NPS-2005-PARTS-34	1	SATO PARTS:BN-8-1-G(100V), BN-8-2-G(200V)
35	PUSH SWITCH SOCKET	NPS-2005-PARTS-35	1	IDEC:MA9Z-C2
36	COOLING FAN	NPS-2005-PARTS-36	2	OMRON:R87F-A3A93HP(100V), R87F-A3A93HP(200V)
37	COOLING FAN CABLE	NPS-2005-PARTS-37	2	OMRON:R87FPC
38	COOLING FAN GUARD	NPS-2005-PARTS-38	2	OMRON:R87F-FG120
39	NOISE FILTER INLET	NPS-2005-PARTS-39	1	NEC/TOKIN GL-2100M
40	SURGE PROTECTOR BRACKET	NPS-2005-PARTS-40	1	OKAYA:RAM-302BWZ
41	POWER CORD	NPS-2005-PARTS-41	1	MISUMI:ULJP-C-ULJPSS-3(100V), CEE3P-WS-3(200V)
42	FUSE HOLDER	NPS-2005-PARTS-42	1	SATO PARTS:F-400-01B2
43	FUSE	NPS-2005-PARTS-43	1	φ 5.2 × 20, 250V 10A
44	CABLE BUSH	NPS-2005-PARTS-44	1	MISUMI:ST-M16-B.GMP-GLM16-B-10P
45	THERMAL FUSE	NPS-2005-PARTS-45	1	EMERSON:E4A229C
46	SURGE PROTECTOR	NPS-2005-PARTS-46	1	OKAYA:R·A·M-302BWZ
47	HEAT SINK FIXATION SCREW	NPS-2005-PARTS-47	4	PAN HEAD SCREW M5 × 12 SW
48	THERMAL FUSE FIXATION SCREW	NPS-2005-PARTS-48	1	HEXAGON SOCKET SCREW M3 × 3
49	BOTTOM HEAT PLATE FIXATION SCREW	NPS-2005-PARTS-49	4	COUNTERSUNK SCREW M4 × 45
50	CONTROL BOX FIXATION SCREW	NPS-2005-PARTS-50	4	TRUSS SCREW M6 × 10
51	GUIDE ARM FIXATION SCREW	NPS-2005-PARTS-51	2	HEXAGON BOLT M6 × 16 PW, SW
52	TOP HEAT PLATE FIXATION SCREW	NPS-2005-PARTS-52	4	PAN HEAD SCREW M4 × 40 SW
53	METAL MESH FIXATION SCREW	NPS-2005-PARTS-53	4	PAN HEAD SCREW M4 × 6
54	COVER STAY FIXATION SCREW	NPS-2005-PARTS-54	4	PAN HEAD SCREW M5 × 10 PW, SW
55	ARCH GRIP FIXATION SCREW	NPS-2005-PARTS-55	2	HEXAGON SOCKET HED CAP SCREW M8 × 16
56	TORQUE LIMITER FIXATION SCREW	NPS-2005-PARTS-56	1	HEXAGON SOCKET SCREW M4 × 8
57	CONTROL PANEL FIXATION SCREW	NPS-2005-PARTS-57	6	PAN HEAD SCREW M4 × 10
58	HINGE PIN RETAINING RING	NPS-2005-PARTS-58	2	RETAINING RING E-Type φ6
59	PRESETTER GUIDE FIXATION SCREW	NPS-2005-PARTS-59	4	PAN HEAD SCREW M4 × 30 PW, SW
60	TEMPERATURE SENSOR FIXATION SCREW	NPS-2005-PARTS-60	1	PAN HEAD SCREW M3 × 5
61	COOLING FAN FIXATION SCREW	NPS-2005-PARTS-61	6	PAN HEAD SCREW M4 × 35 PW, SW, N
62	SSR FIXATION SCREW	NPS-2005-PARTS-62	2	PAN HEAD SCREW M4 × 10
63	SSR BRACKETBKT FIXATION SCREW	NPS-2005-PARTS-63	2	PAN HEAD SCREW M4 × 10
64	NOISE FILTER FIXATION SCREW	NPS-2005-PARTS-64	2	PAN HEAD SCREW M3 × 6 PW, SW
65	EARTH CABLE FIXATION SCREW	NPS-2005-PARTS-65	1	PAN HEAD SCREW M4 × 10 N
66	SURGE PROTECTOR MOUNT FIXATION SCREW	NPS-2005-PARTS-66	2	PAN HEAD SCREW M4 × 10
67	SURGE PROTECTOR FIXATION SCREW	NPS-2005-PARTS-67	1	PAN HEAD SCREW M4 × 10

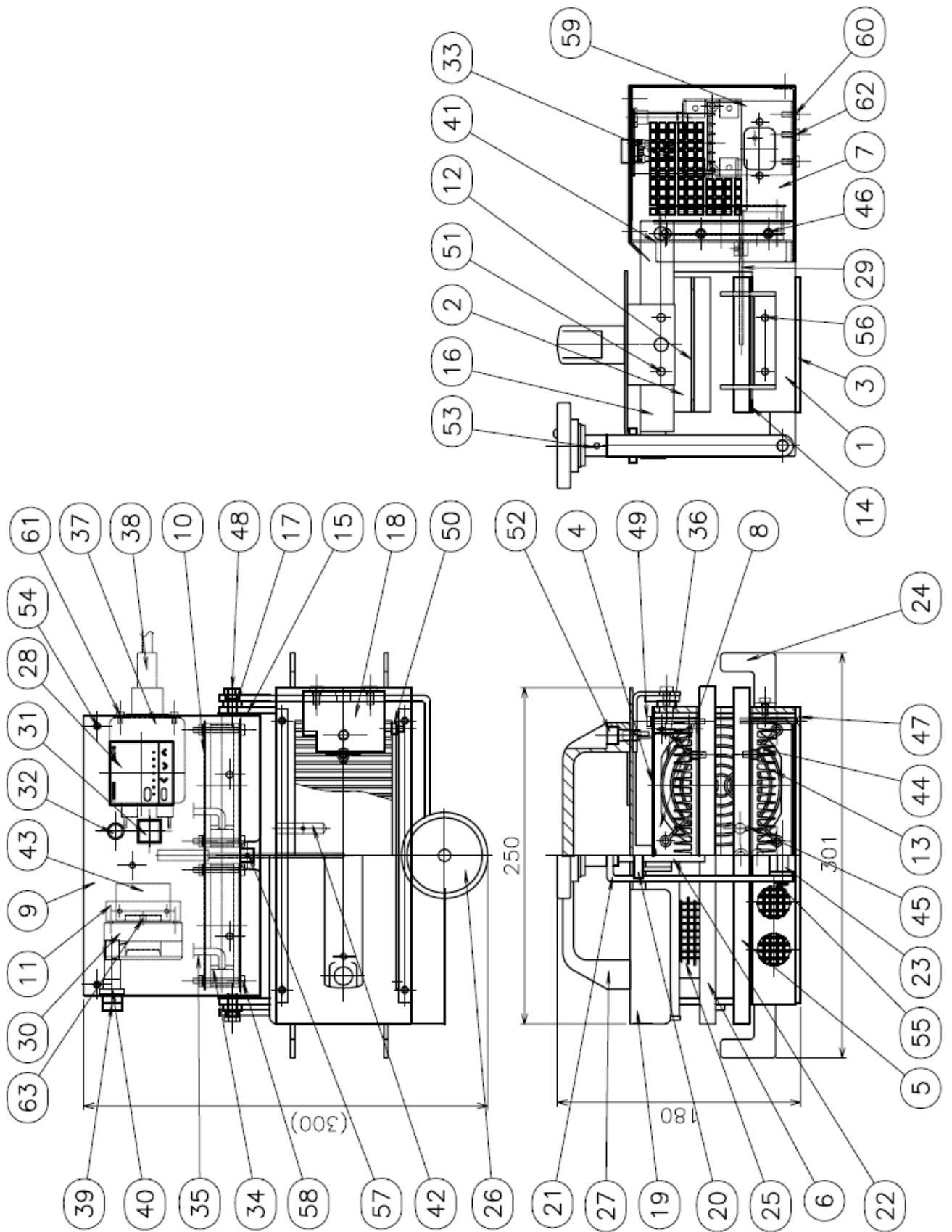

10. Troubleshooting

Problem	Cause	Solution	
No display on the temperature controller	The power plug has been disconnected.	Connect the power plug.	
	The fuse has blown out.	Replace the fuse.	
	Is power supplied to the outlet?	Yes	Failure of the temperature controller or disconnection of power cable or internal wiring is suspected. * Please contact your local distributor, agent in your area or our company.
		No	Supply power to the outlet.
The temperature controller gives a display starting with AL. (AL01 - AL99)	Defective data on temperature controller	Disconnect the power plug once and connect it again. * If the alarm display does not disappear, failure on the temperature controller is suspected. * Please contact your local distributor, agent in your area or our company.	
Temperature and hold time cannot be set.	Setting change is not possible for 6 sec. right after power ON.	Wait 6 sec. or more to make a setting.	
	The (para) and other buttons were pushed right after the preset value was changed.	To fix the preset value, avoid pushing buttons for 2 sec. or more.	
	Other than the above: Failure of the temperature controller	If setting is not possible even by the above methods, failure on the temperature controller is suspected. * Please contact your local distributor, agent in your area or our company.	
Cannot be heated to the set temperature.	Does power supply not match the specification?	Yes	Use the correct power supply.
		No	Failure of the temperature controller or disconnection of internal wiring is suspected. * Please contact your local distributor, agent in your area or our company.
The cooling fan does not operate.	Has preset temperature been set to around 45 °C?	Yes	This machine has been set to end cooling at 45 °C. Setting the temperature to around 45 °C may cause the cooling fan to operate incorrectly. Set the preset temperature higher.
		No	Failure of the cooling fan or disconnection of internal wiring is suspected. * Please contact your local distributor, agent in your area or our company.
The rotary handle slips and cannot be loosened.	The rotary handle was turned excessively.	Lightly tap the handle from the rear to the front with a plastic hammer while taking care not to give the press any strong jolts. * Throttling force is sufficient when the rotary handle begins to slip.	

11. Inspection

Check item	Date/check	Date/check	Date/check	Date/check	Date/check
The power cable has no flaws.					
The temperature controller is not damaged.					
There are no screws or parts missing.					
The machine body is not damaged.					
Heat plates have no resin or foreign matter adhering to them.					
The pre-setter has no flaws.					
The pre-setter has no resin or foreign matter adhering to it.					
The hook or rotating handle has no distortion.					

* Please make copies of this page and use them for daily check before use.

NITTA CORPORATION

4-4-26 Sakuragawa Naniwa-ku, Osaka 556-0022 Japan
Phone:+81-6-6563-1225 Fax:+81-6-6563-1242

<http://www.nitta.co.jp>

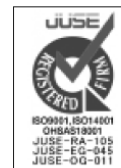

NITTA CORPORATION OF AMERICA

7605 Nitta Drive, Suwanee, GA 30024, U.S.A.
Phone:+1-770-497-0212 Fax:+1-770-623-1398
<http://www.nitta.com>

NITTA CORPORATION OF HOLLAND B.V.

Berenkoog 25, 1822 B.H. Alkmaar, The Netherlands
Phone:+31-72-5622234 Fax:+31-72-5613238
<http://www.nitta.nl>

NITTA(SHANGHAI) MANAGEMENT CO., LTD

Room2705, Shenggao International Building, No.137 Xianxia Road, Shanghai 200051
Phone:+86-21-6229-6000 Fax:+86-21-6229-9606
<http://www.nitta-cn.com>

NITTA CORPORATION INDIA PVT LTD

Gat No.186, Village Fulgaon, Taluka Haveli, Pune, Maharashtra 412216, INDIA
Phone:+91-20-6731-3400 Fax:+91-20-6731-3401

NITTA CORPORATION KOREA OFFICE

Room710, 7F, ShinhanDM Bldg. Mapo-daero 25, Mapo-gu, Seoul, Korea
Phone:+82-2-3274-1252 Fax:+82-2-3274-1253
<http://www.nitta.kr>

NITTA INDUSTRIES EUROPE GmbH

Hansaallee 201, 40549 Dusseldorf, Germany
Phone:49-211-537535-0 Fax:+49-211-537535-35
<http://www.nitta.de/>

NITTA CORPORATION OF SINGAPORE PTE LTD

120 Lower Delta Road, #05-07/08
Cendex Centre, Singapore 169208
Phone:+65-6438-8738 Fax:+65-6438-8793
<http://www.nitta.com.sg>
<Thai Liaison Office>Phone:+66-2797-0723
<Indonesia Liaison Office>Phone:+62-22-421-3146

TAIWAN NITTA FILTER CO.,LTD.

Headquarters: Chia Hsin Building 10FL Room No. 1005, 96 Chung Shan North Road Section 2, Taipei, Taiwan, R.O.C.
Phone:+886-2-2581-6296 Fax:+886-3-469-0260
<http://www.nitta.com.tw>

NITTA BRASIL

Rua Francisco Mommenshon, 50B, Galpão 02
Laranjeiras, Caieiras, São Paulo, Brazil
Phone/Fax:+55-11-4441-2922

The specification is subject to change for improvement without notice.

Oct 2015 Rev5 NPS-2005R-E