

PolySprint™

Integral Heating and Cooling Press **NPS-1210-1/2** **OPERATOR'S MANUAL**

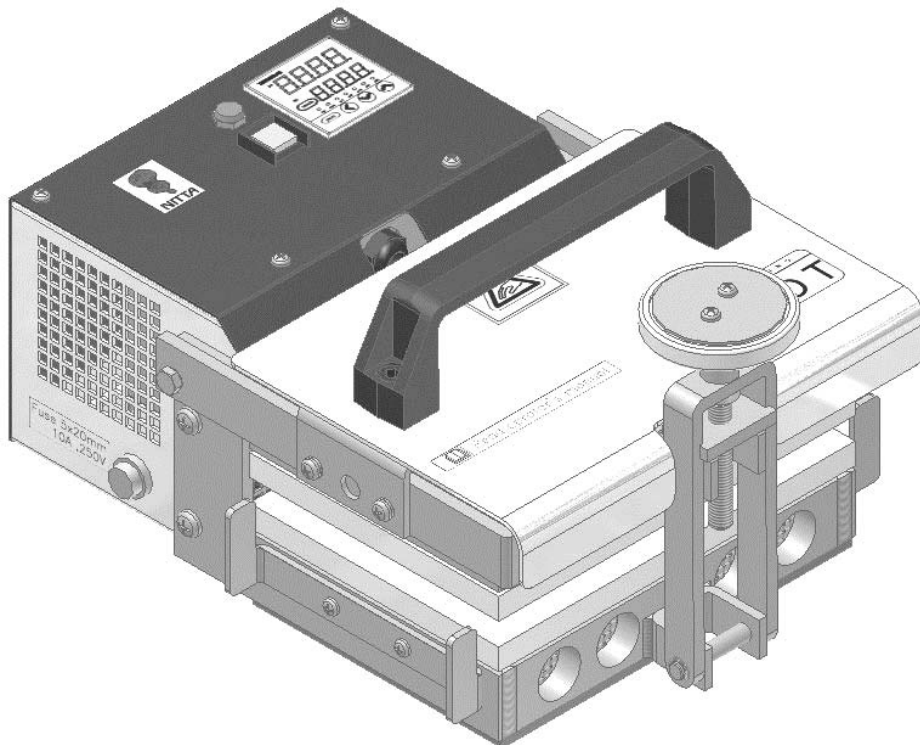

Thoroughly read this operator's manual before operating the press.



To use endless splicing tools safely, be sure to hand this manual to the operator or worker.

NITTA CORPORATION

Table of Contents

1. Precautions for the Safety	2
2. Confirmation of Product	6
3. Specification	7
4. Operation Environment	8
5. Storage Environment	8
6. Name of each parts	9
7. Operation Procedure	11
8. Endless Splicing Procedure	13
9. Troubleshooting	17
10. Inspection	18

1. Precautions for the Safety

We would like to thank you for having purchased our Integral Heating and Cooling Press NPS-1210-1/2.

Thoroughly read this manual, especially the chapter of Precautions for the Safety, to use this machine safely.



This indicates a hazardous situation which, if improperly handled, will result in death or serious injury.



This indicates a potentially hazardous situation which, if improperly handled, will result in minor injury or property damage.

WARNING



- **Do not use this machine for any use other than belt endless splicing.**
Any use not intended for the prescribed purpose may invite an unexpected accident. Improper use may possibly spoil the safety protection function of the product.



- **This machine is not intended for the physical, sensory or mental handicapped persons use. They must have the supervision of a person responsible for their safety, if they use this machine.**
Failure to do this may cause fire, electric shock or injury.



- **Do not allow the child to handle this machine. Keep this machine in the place where child's hand does not reach.**
Failure to do this may cause fire, electric shock or injury.



- **A person with technical knowledge and skills should always operate, maintain and inspect this machine.**
Handling by a person not having technical knowledge may cause fire, electric shock or injury.



- **Strictly avoid disassembling or remodeling this machine.**
Disassembling or remodeling this machine may cause fire or electric shock. When repair or check is required, please contact your local distributor, agent in your area or our company.



- **In the event of trouble (smoke, fire or nasty smell, etc.), please immediately disconnect the power plug and contact your local distributor, agent in you area or our company for inspection or repair.**
Failure to do this may cause fire or electric shock.



- **When not using or carrying this machine, be sure to set the hook and turn the rotary handle until it slips to securely clamp the heat plate.**
Failure to do this may cause injury.



- **Confirm that the power supply to be used is within the designated of specification for this machine.**

Failure to do this may cause fire or electric shock.

Model	Power supply
NPS-1210-1	100 - 120V 50 / 60Hz
NPS-1210-2	200 - 240V 50 / 60Hz



- **Avoid using the press in the following environment.**

Failure to do this may cause fire or electric shock.

- In the atmosphere of inflammable or ignitable gas
- In the atmosphere of corrosive gas
- In the ambient temperature of 5°C or below
- In the ambient temperature of 40°C or above
- In the atmosphere of high humidity (environment where humidity exceeds 85%)
- In the environment subject to wetting by steam, water drop or dew condensation, etc.



- **Be sure to wear heat-resistant gloves when operating this press.**

Failure to do this may cause burn.



- **When operating this press, avoid touching the heat plate area even if wearing heat-resistant gloves.**

Press heat plates get heated to the preset temperature while being heated. Failure to do this may cause burn, even if wearing heat-resistant gloves.



- **Avoid operating the press at the place close to combustible material.**

Failure to do this may cause fire.



- **Always use the pre-setter of our product.**

Failure to do this may cause fire or electric shock.

Use of the pre-setter made by other product may possibly spoil the safety protection function of the product.



- **Use a dry cloth for cleaning this machine. Strictly avoid using alcohol, benzene, thinner or other inflammable solvents.**

Using inflammable solvents may cause fire.



- **Impressed voltage is directly applied to the power cable. Observe the following precautions not to damage the cable.**

Failure to do this may cause fire or electric shock.

- Disconnect the power plug by hand.
- Avoid pulling the cable to disconnect the power plug.
- Avoid remodeling the power plug or replacing the plug with other manufacturers.
- Avoid placing a thing on the power cable.
- Avoid bending the power cable.
- Take care to prevent the power cable from touching the heat plate of the press.





- **Connect the power plug to the socket correctly.**

Failure to do this may cause electric shock.

The power cable of this machine uses an earth connection plug. Connect the power plug correctly into an earth connection socket.



- **Use a conversion plug when the plug shape does not match the socket.**
Failure to do this may cause electric shock.
The plug shape of the attached power cable is as follows. The conversion plug is not attached. When the conversion plug is necessary, the user must prepare it yourself.

Model	Plug type	Plug illustration
NPS-1210-1	A Type	
NPS-1210-2	CEE7 (S Type)	



- **Never handle this machine or the plug, cable, etc. with your hands wetting.**
Failure to do this may cause electric shock.



- **Never use this machine if wetting.**
Failure to do this may cause electric shock or fire.

CAUTION



- **Exercise care not to pinch your hands between the top cover and control box or the upper and lower heat plates.**
Failure to do this may cause injury.

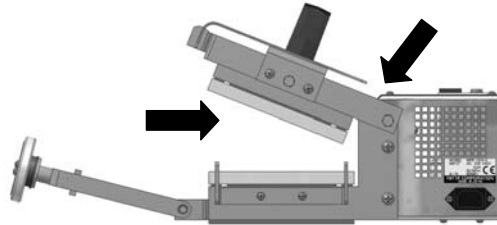

- **Avoid inserting your hands into the opening (part with a wire net) on the front face of the press.**
Failure to do this may cause burn.

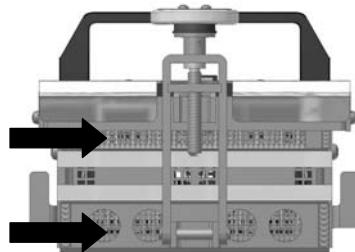

- **Avoid using this machine outdoors.**
This product is not intended for the use outdoors.



- **Avoid dropping this machine or giving a strong shock.**
Failure to do this may cause fire or electric shock.



- **Take a measure to prevent this machine from dropping or falling, or do not install or operate the press at an unstable place.**
Failure to do this may cause injury, fire or electric shock.



- **Carry out the inspection described on page 18 of this manual before operating this machine.**
Failure to do this may cause fire or electric shock.



- **Do not use this machine for the endless splicing of belt of other manufacturers.**
Endless splicing may become imperfect if this machine is used for the endless splicing of belt of other manufacturers.
This may spoil the full functioning and performance of the belt.

2. Confirmation of Product



- Before operating the press, check that the product is exactly what you have ordered. Using this product other than those specified in this manual may cause fire, electric shock, injury or burn.

2-1) Confirmation of Product

On opening the package, confirm the following points.

- 1) Are descriptions on the nameplate the same as those of your order item?
Confirm the model and power supply specification.
- 2) Aren't there any breakage or lack?
The packages contain this manual, the press and power cable.
- 3) Has screw and nut loosened?

We make assurance doubly sure on the inspection and shipment of products. In the event of any defect or failure, if any, please contact your local distributor, agent in your area or our company.

2-2) Confirmation of the nameplate

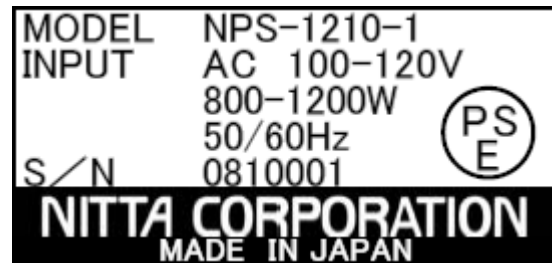

MODEL: Press model
INPUT: Input power supply specification and power consumption
S/N: Serial number

2-3) Press model

Final numbers 1 and 2 of the model indicate the specification of input power supply.
Number 1 indicates the AC100 - 120V specification, and 2 the AC200 - 240V specification.

2-4) Notes for inquiry

When making inquiry, please contact us together with the press model and serial number.

4. Operation Environment

Ambient temperature	5 – 40°C (no dew condensation)
Ambient humidity	15 – 85%R.H.
Working place	Indoor (place without dust and water)
Atmosphere	No inflammable, combustible or corrosive gas and steam



- **Avoid using this machine in the following environment.**
Failure to do this may cause fire or electric shock.
 - In the environment of inflammable or combustible gas
 - In the environment of corrosive gas
 - In the ambient temperature of 5°C or below
 - In the ambient temperature of 40°C or above
 - In the environment of high humidity (humidity exceeds 85%)
 - In the environment of wetting by steam, water drop or dew condensation, etc.

5. Storage Environment

Ambient temperature	5 - 40°C (no dew condensation)
Ambient humidity	15 - 85%R.H.
Working place	Indoor (place without dust and water)
Atmosphere	No inflammable, combustible or corrosive gas and steam



- **When not in use, store this machine under the above conditions.**
Poor storage condition may cause mechanical disorder this machine and may cause electric shock or fire.



- **When not using or carrying the machine, be sure to set the hook and turn the rotary handle until it slips.**
Insufficient clamping may cause injury.



- **Before operating the machine, be sure to conduct the prior-to-use inspection and confirm the normal performance.**
In the event any abnormality is found in the prior-to-use check, please immediately contact your local distributor, agent in your area or our company.

6. Name of each Part

6-1) Front view of the press

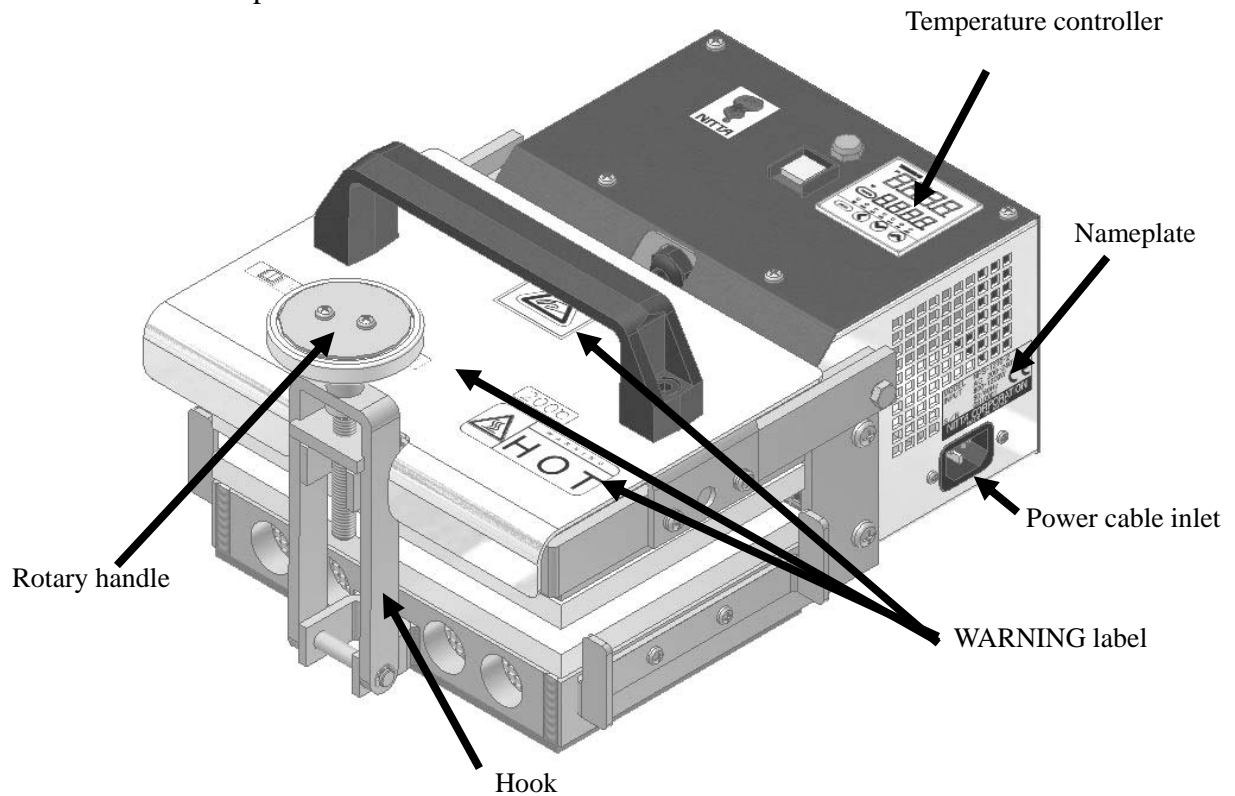

6-2) Rear view of the press

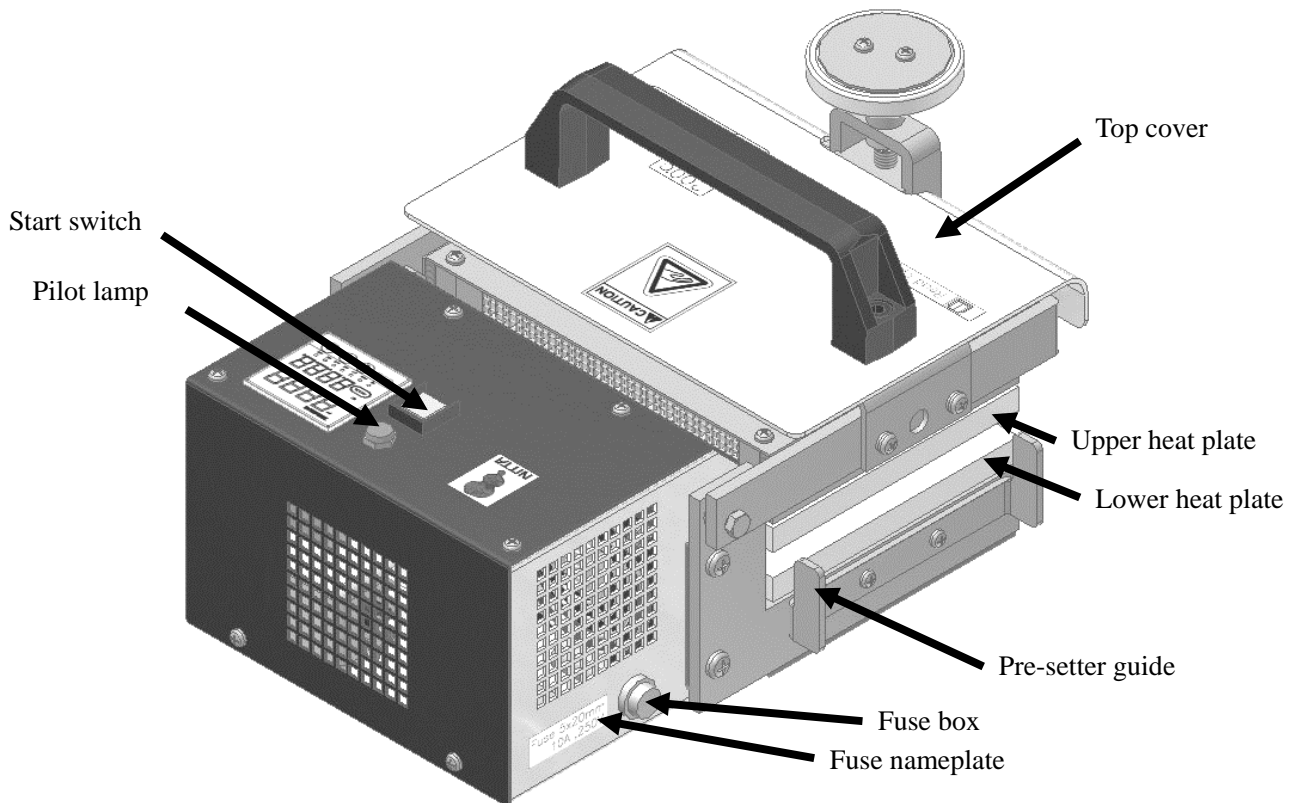

6-3) Temperature controller

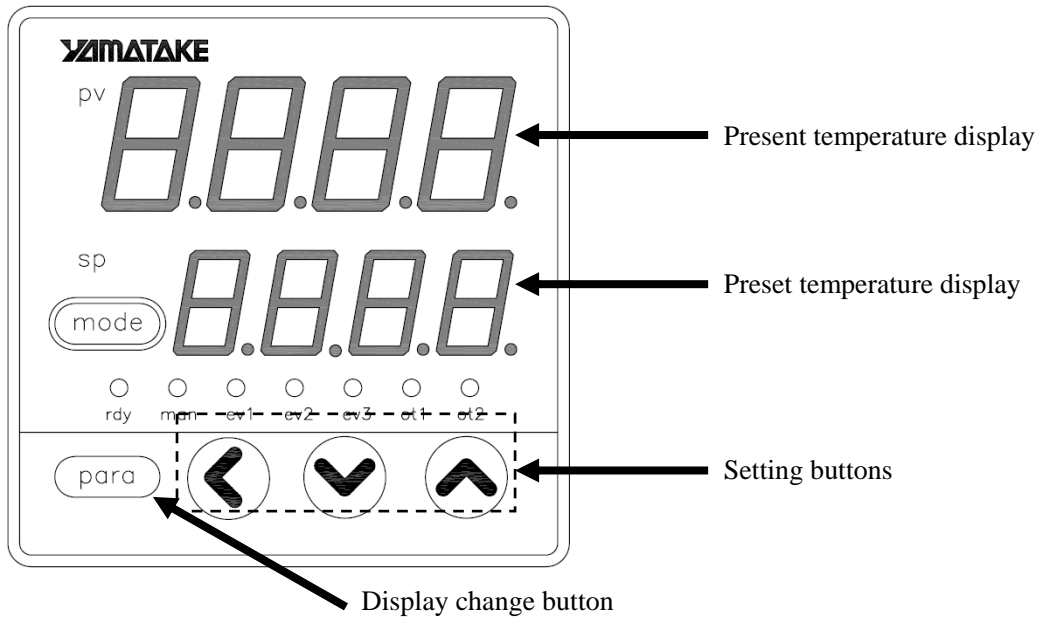

7. Operation Procedure

7-1) Power ON

Connect the power plug to the socket correctly.

The power is supplied to the temperature controller. The controller indicates the present temperature (upper display) and preset temperature (lower display).



· **Be sure to connect an earth line.**

7-2) Temperature setting (Temperature controller)

- 1) Check that the pilot lamp is off (no heating or cooling).
- 2) Push the (para) display change button three times to indicate “SP-1” on the present temperature display. At this time, the preset temperature display indicates the preset temperature.
* **The preset temperature before shipping is 190°C.**
- 3) Push the (▲) (up) button to raise the preset temperature or push the (▼) (down) button to lower. Push the button once and the flickering figure increase or decrease 1°C each time. Pushing the (◀) (side) button shifts the figure of temperature.
- 4) The figure of the preset temperature display is flickering when the figure of the temperature is adjusting.
The preset temperature will be fixed when no pushing is made for 2 sec or more.
- 5) Push the (para) display change button two times to return the present temperature display to the original state.

7-3) Hold time setting (Temperature controller)

- 1) Check that the pilot lamp is off (no heating or cooling).
- 2) Push the (para) display change button four times to indicate “E1.on” on the present temperature display. At this time, the preset temperature display indicates the hold time (in sec).
* **The hold time before shipping is 60 sec.**
- 3) Push the (▲) (up) button to increase the time or push the (▼) (down) button to decrease. Push the button once and the flickering figure increase or decrease 1 sec each time. Pushing the (◀) (side) button shift the figure of hold time setting.
- 4) The figure of the hold time display is flickering when the figure of the hold time is adjusting.
The hold time setting will be fixed when no pushing is made for 2 sec or more.
- 5) Push the (para) display change button once to return the present temperature display to the original state.
The indicator of temperature returns to the preset temperature.



· **Although changing the preset temperature and hold time is possible also during heating or cooling, heating or cooling may become incorrect. Hence avoid changing the setting during heating or cooling since it may cause incorrect endless splicing.**

7-4) Operation

- 1) To start operation, push the start switch for 0.5 sec or more.
- 2) On starting of operation, the pilot lamp lights and the heating of upper and lower heat plates start.
- 3) The machine operates in the sequence of; heating to the preset temperature, temperature holding (period previously set) and cooling. On completion of temperature holding, the pilot lamp goes off, and the machine operate the cooling fan until present temperature goes below 45°C.
- 4) When present temperature goes below 45°C, the cooling fan stops and the machine become a standby.



- **Be sure to wear heat-resistant gloves when operating the press.**
Failure to do this may cause burn.



- **An operator should not leave the machine in use. Take a measure to prevent other people from touching this machine unexpectedly.**
Failure to do this may cause burn on other people.

7-5) Discontinue on the way

Disconnect the plug if it becomes necessary to discontinue the machine in operation.

- * **Even if the plug is disconnected in operation, preset data of preset temperature and hold time are maintained.**



- **The machine when discontinued on the way is kept at high temperature. Be sure to wear heat-resistant gloves when handling the machine.**
Failure to do this may cause burn.



- **The operator should take a measure to prevent other people from touching this machine unexpectedly, until the machine temperature lowers near to room temperature (about two hours).**
Failure to do this may cause burn on other people.



- **When the machine is discontinued on the way in making belt endless splicing, do not use the belt.**
Endless splicing may become imperfect possibly spoiling the full functioning and performance of the belt.

8. Endless Splicing Procedure

8-1) Required Tool



Figure/Photo	Description
	<p>Fig. a Integral Heating and Cooling Press [NPS-1210-1/2]</p> <p>Fig. b Heat resistant gloves (burn-preventive protection kits) This item is not contained in the product package. The user must prepare gloves yourself.</p> <p>Fig. c Pre-setter This item is not contained in the product package. The pre-setter is required for each width belt.</p> <p> WARNING</p> <ul style="list-style-type: none"> ▪ This machine reaches a high temperature. Be sure to prepare heat-resistant gloves and wear it. Failure to do this may cause burn.

8-2) Belt setting

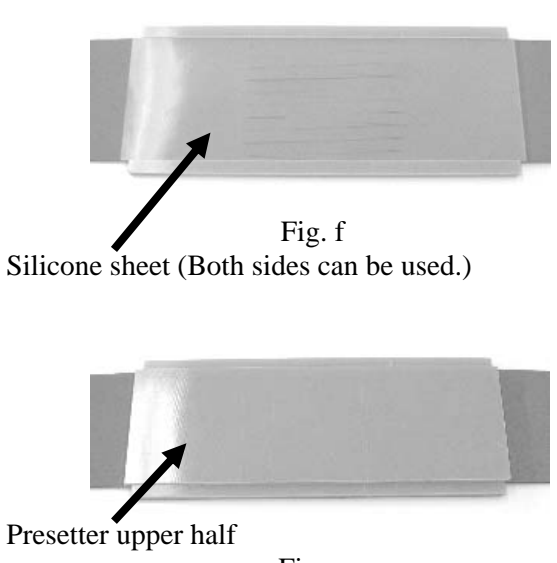
Figure/Photo	Description
	<ol style="list-style-type: none"> 1) Set both ends of the belt punched into finger shape beforehand on the lower pre-setter as shown in Fig. d. <ul style="list-style-type: none"> * Exercise care not to twisting on the way of belt. * Confirm the front side and the back side of belt before setting. Refer to the attached endless condition table. <p> WARNING</p> <ul style="list-style-type: none"> ▪ Always use the pre-setter of our product. Use of any other product possibly results in an improper endless joint and may cause fire. 2) Set the belt by mating finger joints leaving no gap so that the joint part is located within marking lines on the pre-setter as shown in Fig. e.

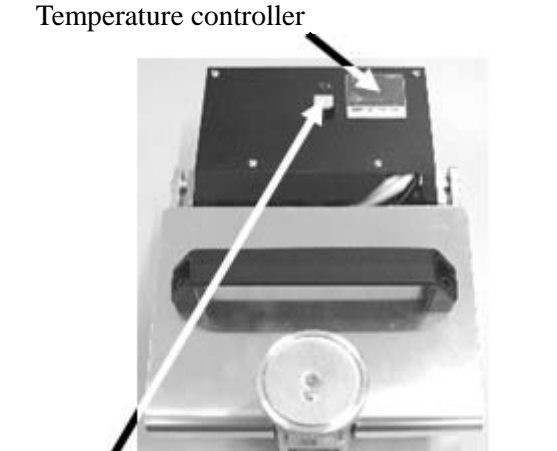

Figure/Photo	Description
 <p data-bbox="159 224 718 336">Silicone sheet (Both sides can be used.) Fig. f</p> <p data-bbox="159 560 718 784">Presetter upper half Fig. g</p>	<p data-bbox="798 224 1420 291">3) Set the silicone sheet on the belt as shown in Fig. f.</p> <ul data-bbox="798 291 1420 425" style="list-style-type: none"> * Remove any dust or foreign object on the silicon sheet before operation. * Change the sheet if deteriorated, scratched or torn. <p data-bbox="798 448 1420 515">4) Place the upper pre-setter over the silicone sheet as shown in Fig. g.</p> <ul data-bbox="798 515 1420 627" style="list-style-type: none"> * The upper pre-setter has also marking lines. Place the upper pre-setter over the lower one while mating the marking lines.

8-3) Preparation of press

Figure/Photo	Description
 <p data-bbox="159 1008 718 1120">Temperature controller</p> <p data-bbox="159 1456 718 1568">Start switch (Do not touch now.) Fig. h</p>	<p data-bbox="798 985 1420 1030">1) Connect the power plug to the socket.</p> <div data-bbox="829 1030 1420 1142">  <p data-bbox="829 1030 1420 1142">WARNING Be sure to connect an earth line. Failure to do this may cause electric shock.</p> </div> <p data-bbox="798 1164 1420 1299">2) Set the preset temperature and hold time on the temperature controller according to sections 7-2) Temperature setting and 7-3) Hold time setting on page 11.</p> <ul data-bbox="798 1299 1420 1500" style="list-style-type: none"> * Preset temperature and hold time differ by belt widths. Set them by referring to the attached endless condition table. * Avoid touching the start switch before setting the belt and then clamping the hook.

8-4) Endless splicing

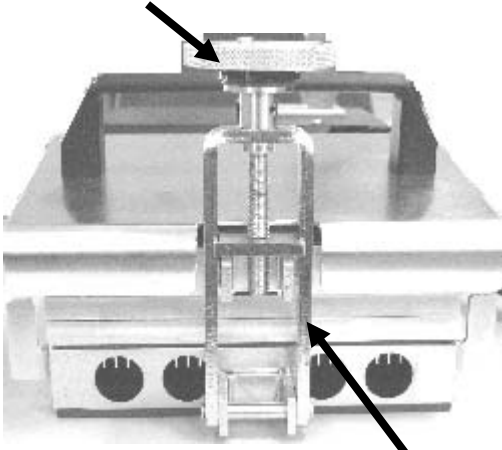
Figure/Photo	Description
<div data-bbox="225 293 735 629" data-label="Image"> </div> <div data-bbox="245 981 708 1442" data-label="Image"> </div>	<div data-bbox="820 271 1015 349" data-label="Image"> </div> <ul style="list-style-type: none"> • This machine reaches a high temperature in operation. Wear heat-resistant gloves when carrying out the following works. <ol style="list-style-type: none"> 1) Place the pre-setter prepared as described in section 8-2) Belt setting on page 12, between pre-setter guides as shown in Fig. i. <ul style="list-style-type: none"> * Place the pre-setter at the center as much as possible. * When placing, be careful not to pull out the belt from the pre-setter. 2) Gradually close the top cover so that the upper plate is positioned in parallel with the pre-setter. <ul style="list-style-type: none"> * Quick closing the top cover may cause the pre-setter to shift its position or the belt to come off the pre-setter. 3) Set the hook and turn the rotary handle until it slips as shown in Fig. j. <ul style="list-style-type: none"> * Excessive turning will cause the handle to slip in removing also, disturbing easy removing. 4) Push the start switch to start endless splicing. <ul style="list-style-type: none"> * It takes about 60 min to finish one cycle of operation (heating, temperature holding and cooling) with the presetting before shipping at 23°C of environmental temperature. * The required time changes according to ambient environmental temperature or the setting of preset temperature or hold time of the press. 5) On completion of temperature holding, the pilot lamp goes off and operate the cooling fan. Check that the cooling fan has stopped after cooling completion before opening the top cover. 6) Take out the pre-setter and remove the upper one, silicone sheet and belt in order. <ul style="list-style-type: none"> * Use the belt after it has cooled down to room temperature.

Figure/Photo	Description
<p data-bbox="191 206 359 235">Rotary handle</p>  <p data-bbox="622 705 694 734">Hook</p> <p data-bbox="430 739 510 772">Fig. k</p>	<p data-bbox="805 235 1412 369">7) To continue endless splicing, prepare the pre-setter by following the procedure of section 8-2) Belt setting and then repeat the procedure of section 8-4) Endless splicing.</p> <div data-bbox="821 380 1013 459">  </div> <ul data-bbox="1029 369 1412 470" style="list-style-type: none"> ▪ Be sure to wear heat-resistant gloves when operating the press. <p data-bbox="805 504 1396 638">8) To end operation, check that cooling is completed. Then set the hook and turn the rotary handle to lock before disconnecting the power plug as shown in Fig. k.</p> <div data-bbox="821 649 1013 728">  </div> <ul data-bbox="1029 638 1412 772" style="list-style-type: none"> ▪ Securely clamp the hook and rotary handle. Insufficient clamping may cause injury.

9. Troubleshooting

Abnormal phenomenon	Cause	Solution	
No display on the temperature controller	The power plug has been disconnected.	Connect the power plug.	
	The fuse has blown out.	Replace the fuse.	
	The power is supplied to the socket.	Yes	Failure of the temperature controller or disconnection of power cable or internal wiring is suspected. * Please contact your local distributor, agent in your area or our company.
		No	Supply the power to the socket.
The temperature controller gives a display starting with AL. (AL01 - AL99)	Defective data of temperature controller	Disconnect the power plug once and connect it again. * If the alarm display does not disappear, failure on the temperature controller is suspected. * Please contact your local distributor, agent in your area or our company.	
Temperature and hold time cannot be set.	Setting change is not possible for 6 sec right after power ON.	Wait 6 sec or more to make a setting.	
	The (para) and other buttons is pushed right after the preset value was changed.	To fix the preset value, avoid push the button for 2 sec or more.	
	Other than the above. Failure of the temperature controller	If setting is not possible even by the above controlling, failure on the temperature controller is suspected. * Please contact your local distributor, agent in your area or our company.	
Can not be heated to the set temperature.	The power supply is not same as the specification.	Yes	Impress the suitable power supply.
		No	Failure of the temperature controller or disconnection of internal wiring is suspected. * Please contact your local distributor, agent in your area or our company.
The cooling fan does not operate.	Preset temperature has been set to around 45 °C.	Yes	This machine has been set to end cooling at 45 °C of temperature. Setting the temperature to around 45 °C may cause the cooling fan to operate incorrectly. Set the preset temperature higher.
		No	Failure of the cooling fan or disconnection of internal wiring is suspected. * Please contact your local distributor, agent in your area or our company.
The rotary handle slips and cannot be loosened.	The rotary handle was turned excessively.	Lightly hit the handle from the rear to the front with the plastic hammer while taking care not to give a strong shock. * Throttling force is sufficient when the rotary handle begins to slip.	

10. Inspection

Check item	Date/check	Date/check	Date/check	Date/check	Date/check
The power cable have no flaw.					
The temperature controller is not damaged.					
There is no screw or part missing.					
The machine body is not damaged.					
Heat plates have no resin or foreign matter adhered.					
The pre-setter have no flaw.					
The pre-setter have no resin or foreign matter adhered.					
The hook or rotating handle have no distortion.					

* Please make copies of this page and use them for daily check before use.

NITTA CORPORATION

4-4-26 Sakuragawa Naniwa-ku, Osaka 556-0022 Japan
Phone:+81-6-6563-1225 Fax:+81-6-6563-1242

<http://www.nitta.co.jp>



NITTA CORPORATION OF AMERICA

7605 Nitta Drive, Suwanee, GA 30024, U.S.A.
Phone:+1-770-497-0212 Fax:+1-770-623-1398
<http://www.nitta.com>

NITTA CORPORATION OF HOLLAND B.V.

Berenkoog 25, 1822 B.H, Alkmaar, The Netherlands
Phone:+31-72-5622234 Fax:+31-72-5613238
<http://www.nitta.nl>

NITTA(SHANGHAI) MANAGEMENT CO., LTD

Room 2705, Shenggao International Building, No.137 Xianxia Road, Shanghai 200051
Phone:+86-21-6229-6000 Fax:+86-21-6229-9606
<http://www.nitta-cn.com>

NITTA CORPORATION INDIA PVT. LTD.

Gat No.186, Village Fulgaon, Taluka Haveli, Pune, Maharashtra 412216, INDIA
Phone:+91-20-6731-3400 Fax:+91-20-6731-3401
<http://www.nitta.co.in>

NITTA CORPORATION KOREA OFFICE

Room 710, 7F, ShinhanDM Bldg. Mapo-daero 25, Mapo-gu, Seoul, Korea
Phone:+82-2-3274-1252 Fax:+82-2-3274-1253
<http://www.nitta.kr>

NITTA INDUSTRIES EUROPE GmbH

Hansaallee 201, 40549 Dusseldorf, Germany
Phone:49-211-537535-0 Fax:+49-211-537535-35
<http://www.nitta.de>

NITTA CORPORATION OF SINGAPORE PTE LTD

120 Lower Delta Road, #05-07/08
Cendex Centre, Singapore 169208
Phone:+65-6438-8738 Fax:+65-6438-8793
<http://www.nitta.com.sg>
<Thailand Liaison Office>Phone:+66-9-0654-9717
<Indonesia Liaison Office>Phone:+62-878-2292-5633

TAIWAN NITTA FILTER CO.,LTD.

Headquarters: Chia Hsin Building 10FL Room No., 1005, 96 Chung Shan North Road Section 2, Taipei, Taiwan, R.O.C.
Phone:+886-2-2581-6296 Fax:+886-3-469-0260
<http://www.nitta.com.tw>

NITTA BRASIL

Rua Francisco Mommenshon, 50B, Galpão 02
Laranjeiras, Caieiras, São Paulo, Brazil
Phone/Fax:+55-11-4441-2922
<http://www.nitta.com.br>

CONNECT CONVEYOR BELTING INC.

405 Industrial Drive Unit 3-8, Milton, Ontario Canada L9T 5B1
Phone:+1-905-878-5552 FAX:+1-905-878-0344
<http://www.connectbelting.com/>

The specification is subject to change for improvement without notice.

Dec, 2016 Rev5 NPS-1210-H E